

## HF-S

*Optimal manoeuvrability  
Save on time, fuel and tyres*

### FEATURES

- light weight
- little mounting space
- little space required for wheel movement
- easy mounting
- simple design, no complex electronics, no batteries
- continuous automatic alignment
- automatic pressurizing
- 15, 18, 24T king-pin load
- axle supplier independent

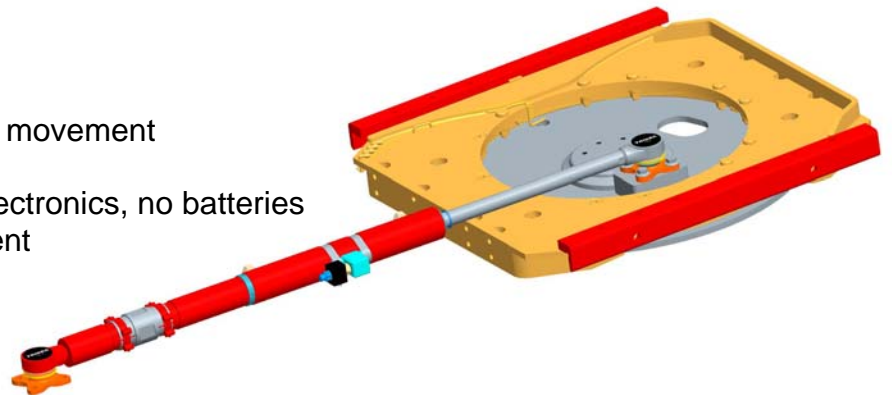

The TRIDEC HF-S hydraulic steering system is applied on trailers for many applications, mainly in distributions transport. This system is a light weight steering for king pin axles that only asks for little mounting space, fitting most common trailer designs. It is an easy and cost effective replacement for self-steered axles, with the benefits of forced steering. The HF-S can also be installed on a tridem boogie, steering the first and last axle (counter steering), obtaining ideal weight distribution and preventing overloading on the driven truck's axle.

### *Delivery contents:*

- *fifth wheel unit*
- *rear cylinder, mounting-bracket included*
- *hydraulic control*
- *(axle not included)*

