



INFO@TRIDEC.NL

WWW.TRIDEC.NL

T +31-(0)499-49 10 50

F +31-(0)499-49 10 60

TRIDEC BV

Transport industry development centre bv

Ekkersrijt 6030

5692 GA Son - Holland

T +31-(0)499-491050

F +31-(0)499-491060



TRIDEC is ISO 9001:2000 certified.



HEAVY-DISTRIBUTION & SPECIAL TRANSPORT

HS

**Hydraulic
steering system**



The hydraulic steering system with steered swivel axles for extendible, tank and rock semi-trailers as well as tippers and ballast trailers



HS ADVANTAGES

THE HYDRAULIC STEERING SYSTEM WITH STEERED SWIVEL AXLES FOR EXTENDIBLE, TANK AND ROCK SEMI-TRAILERS AS WELL AS TIPPERS AND BALLAST TRAILERS

(up to 4 steered axles)

- **HEAVY TRANSPORT / ROUGH TERRAIN**
- **OPTIMAL MANOEUVRABILITY**
- **OPTIMAL VERSATILITY**

The TRIDEC HS steering system is a hydraulic steering system suitable for steering tank trailers, tippers and rock semi-trailers as well as other types of trailers used for heavy industry.

The HS system offers you the possibility of steering 1 to 4 axles, possibly in combination with non-steered stationary axles. An HS system can also be used for extendible trailers.

Your trailer can also be equipped with a manual steering system - The Tritronic - to make your vehicle even more manoeuvrable.

As an option, the system is also available with a central lubrication system.

Visit our website for additional information, and mail or call our sales department for an appointment.

Tridec is an innovative company specialised in the development and manufacture of mechanical and hydraulic steering systems and axle suspension systems for all types of towed vehicles

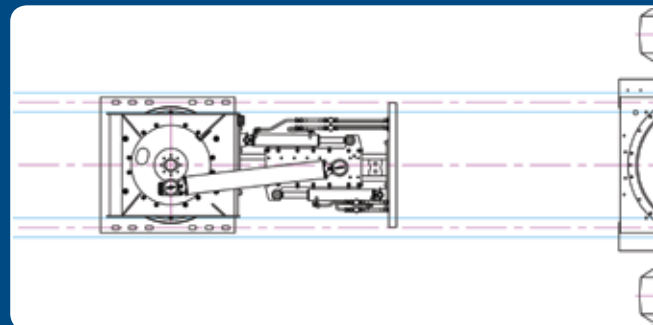

GREATER ACCESSIBILITY

- Optimal manoeuvrability
- Optimal stability
- Optimal controllability
- Optimal versatility

OPTIMAL VERSATILITY

with Tritronic manual steering

- Wireless manual steering
- Automatic alignment
- 8 extra double-acting hydraulic functions possible (or 16 electrical functions)

SAVINGS ON

- Fuel consumption
- Tyre wear
- Vehicle maintenance
- Vehicle damage
- Damage to the surroundings

- **Rough terrain**
- **Extended length and extendible transport possible**

The HS is eminently suited for towed dollies used for the transport of extremely long loads.



HS TECHNOLOGY

HYDRAULISCH

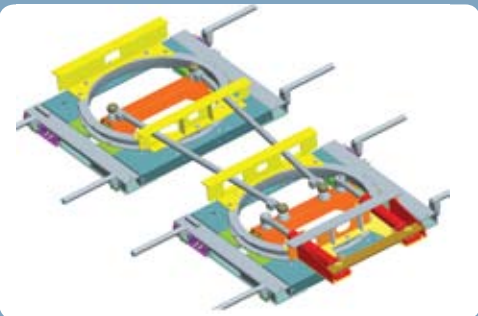
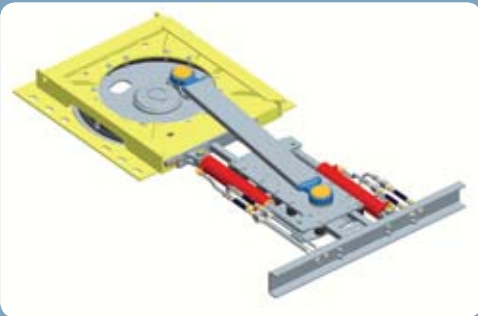
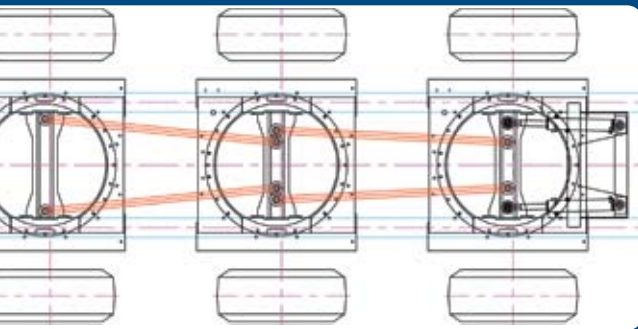

Engineering

Tridec has an advanced engineering department which is responsible for the entire technical preparation and processing of your order. By means of specially developed software, a turning circle calculation can be made that simulates the road space requirements of your trailer on the basis of the current legislation. Through interference checks and construction recommendations, our engineering department can adapt our system to yours to create a perfect match. This gives you a system with the perfect combination between optimum steering and minimum tyre wear.

Maintenance

Maintenance to the TRIDEC HS is limited to lubricating the turntables a few times a year, visual inspection of the hydraulic components and testing the bolt connections. This is possible because high-quality materials and a durable construction are used. The turntables are sealed by a special seal. In addition, all lubricating points are centralised at a single, easily accessible point.

