

W
BW
GW

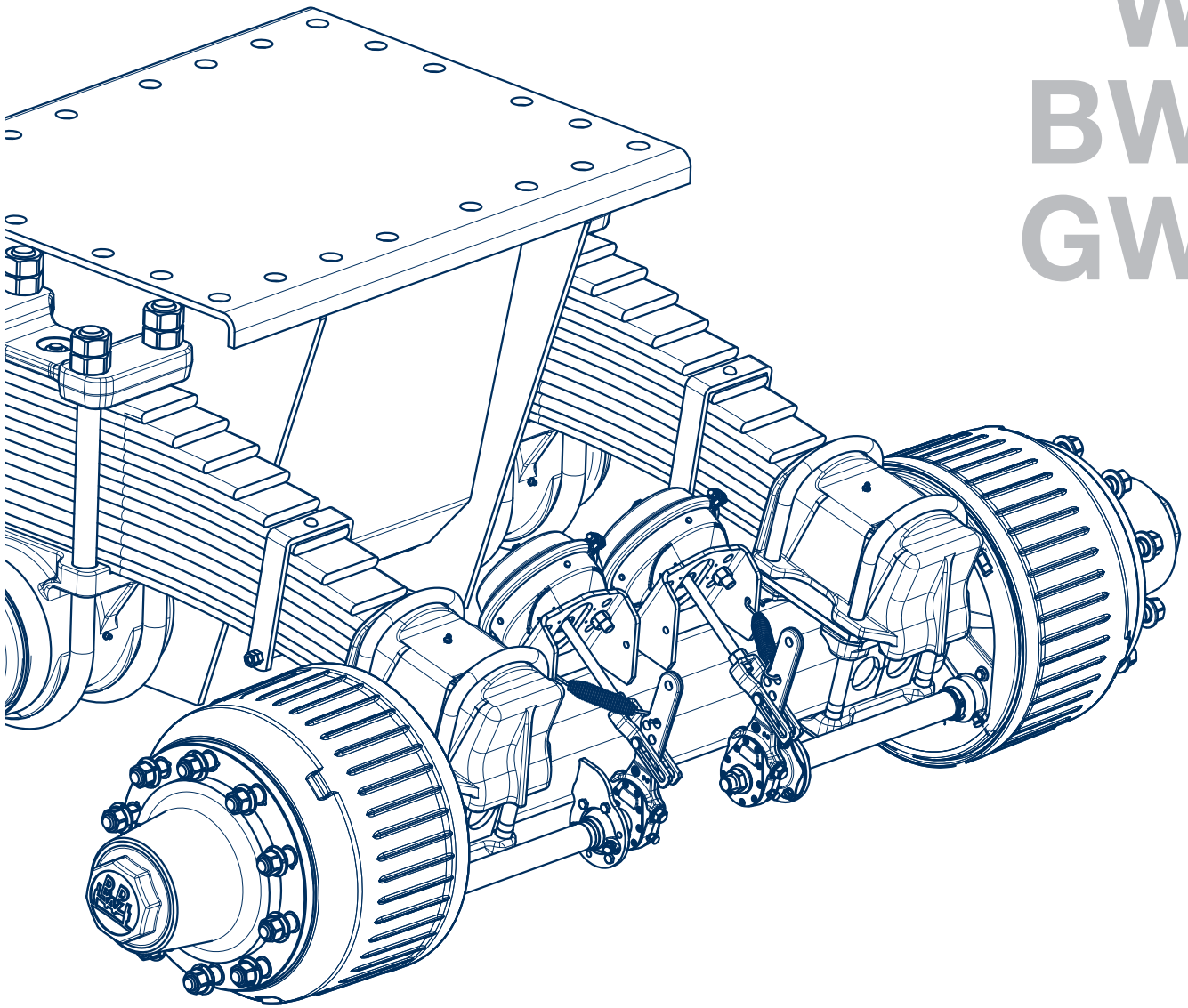

BPW Original-Spare parts

Mechanical suspensions
series W / BW / GW



BPW-EL-W 31261601e

we think transport





BPW-EL-W 31261601e

BPW is a globally leading manufacturer of intelligent running gear systems for trailers and semi-trailers. As an international mobility and system partner, we offer a wide range of solutions for the transport industry from a single source, from axle to suspension and brake to user-friendly telematics applications.

We thereby ensure outstanding transparency in loading and transport processes and facilitate efficient fleet management. Today, the well-established brand represents an international corporation with a wide product and service portfolio for the commercial vehicle industry. Offering running gear systems, telematics, lighting systems, composite solutions and trailer superstructures, BPW is the right system partner for automotive manufacturers.

BPW, the owner-operated company, consistently pursues one target: To always give you exactly the solution which will pay off. To this end, we focus our attention on uncompromising quality for high reliability and service life, weight and time-saving concepts for low operating and maintenance costs as well as personal customer service and a close-knit service network for quick and direct support. You can be sure that with your international mobility partner BPW, you always use the most efficient method.

Your partner on the path to economic viability



BPW Bergische Achsen Kommanditgesellschaft

Postbox 12 80 · 51656 Wiehl, Germany · Phone +49 (0) 2262 78-0
info@bpw.de · www.bpw.de

Contents

		Page	
		Tandem axle suspension series W	Tandem axle suspension series BW / GW
	Explanation of BPW suspension type codes	4	
	Explanation of BPW code numbers	5	
	BPW Type plate	6	
	General explanation of BPW W suspensions	8 / 9	
◎ 1	Leaf springs	10 - 13	
1.1	General	10 / 11	
1.2	Leaf springs	12	
1.3	Spare parts for leaf springs	13	
◎ 2	Axle clampings	14 - 17	
2.1	General	14 / 15	
2.2	Spring seats, axle clampings, safety catch for leaf springs	16 / 17	
◎ 3	Trunnion axle, trunnion axle bearings	18 - 21	
3.1	General	18 / 19	
3.2	Trunnion axle, trunnion axle bearings	20 / 21	
	General explanation of BPW BW / GW suspensions		22 / 23
◎ 4	Leaf springs		24 - 27
4.1	General		24 / 25
4.2	Leaf springs		26
4.3	Spare parts for leaf springs		27
◎ 5	Axle clampings		28 - 31
5.1	General		28 / 29
5.2	Spring seats, axle clampings		30 / 31
◎ 6	Trunnion axle, trunnion axle bearings		32 - 35
6.1	General		32 / 33
6.2	Trunnion axle, trunnion axle bearings		34 / 35
◎ 7	Lubrication and maintenance work	36	

Valid: **1.3.2016**

This spare parts list shows fast moving parts for BPW suspensions **W / BW / GW**.

For further spare parts see BPW spare parts catalogue and / or spare parts lists of the corresponding single axles without bogie parts.

Current versions and additional information can be found online at www.bpw.de.

Subject to change (without notice).

Ⓜ -parts are embossed with BPW Code no.



Contents (Exploded View)

BPW Tandem axle assembly series W

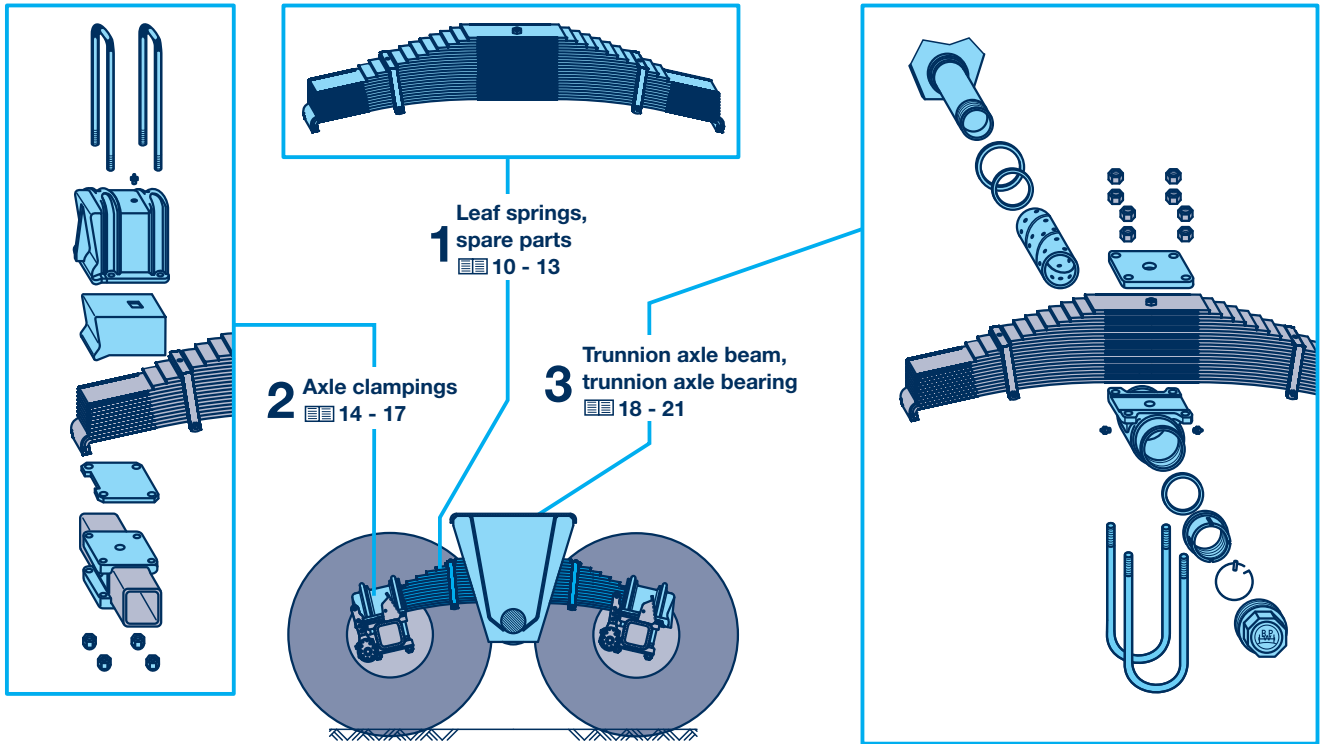

BPW Tandem axle assembly series BW / GW

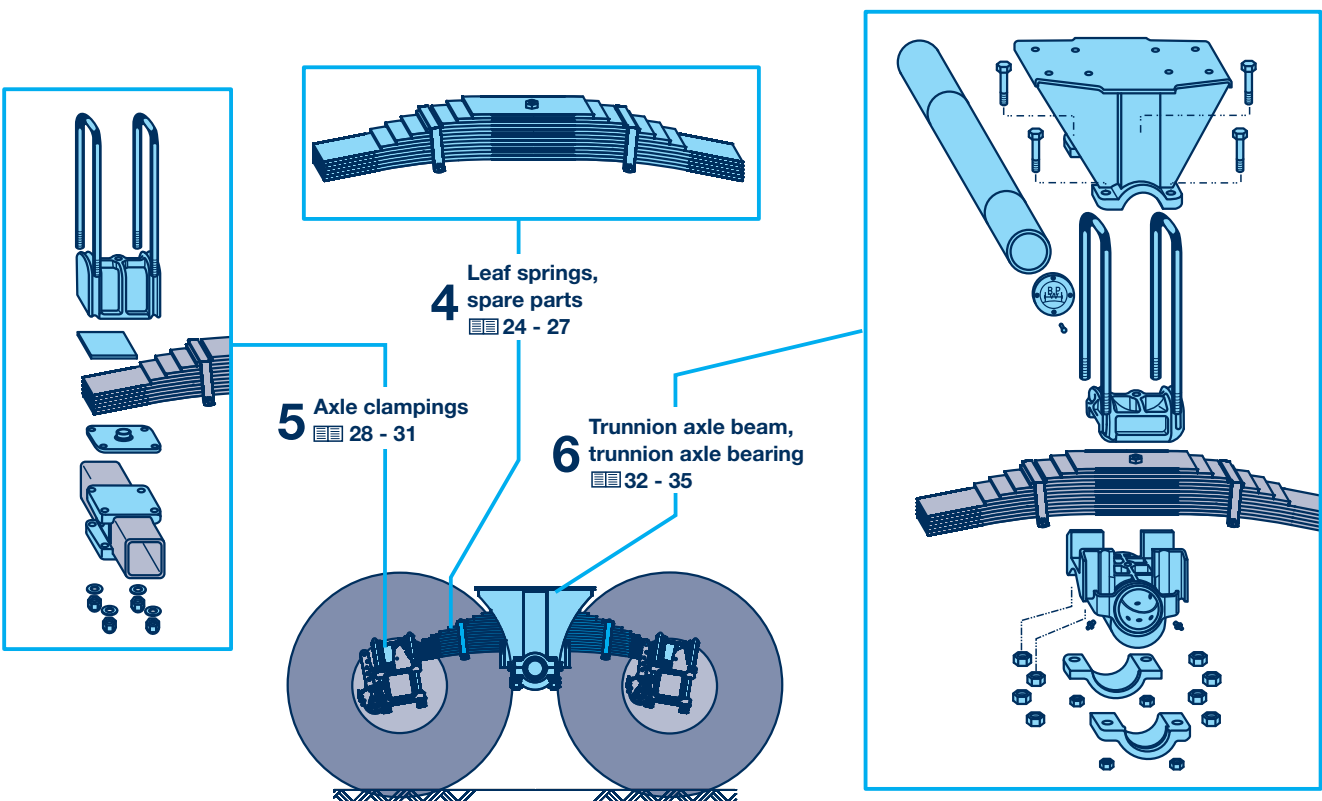

Explanation of BPW suspension type codes

Mechanical suspensions series W / BW / GW (extract)

Example:												
H	Z	F	D	H	W	2/	9010	B	ECO			
										Trailer axle	Brake	Tyre size
EH										EH..	SN 420	20" - 24"
H										H..	SN 360	19.5"
N										N..	SN 300	15" (12"-17.5")
u.a.										Further axle types see BPW type designations		
S										For single wheels, wheels without offset		
Z										For twin wheels		
I										Wheel spiders for TRILEX wheel rims, single wheels		
IZ										Wheel spiders for TRILEX wheel rims, twin wheels		
F										Wheel studs M 22 x 1.5 without wheel nuts, order wheel nuts for stud or spigot alignment separately		
M										For spigot alignment / for alloy wheels		
D										German "Dauerbremse" approval StVZO regulation 41 para 15		
H										For hanging boosters		
										Suspension series		
										W	W Tandem axle assembly, rigid, with two leaf springs and support axle, bearing blocks or high mounting bracket between the leaf springs, with bronze / composite bearing material bushes	
										BW	BW Tandem axle assembly, rigid, with two leaf springs and support axle, bearing blocks above the leaf springs, with bronze bushes	
										GW	GW Tandem axle assembly, rigid, with two leaf springs and support axle, bearing blocks above the leaf springs, with rubber bushes	
										2/	Tandem axle suspension	
										8010 to 20010	Axle load (kg) + quantity of wheel studs per hub	
										B	Version index B	Exec. for harshest conditions
										C	C	Exec. for street conditions
										-1	-1	Type of hub bearings (14 tons)
										-20	-20	Axle beam wall thickness (eg. 20 mm)
										7/8 IN	7/8 IN	Type of wheels studs
										ECO	Single axle with BPW ECO hub system, 1996 (1998) -	
										ECO-MAXX	Weight-optimized ECO -axle, - 2003	
										ECO^{Plus}	Weight-optimized axle with BPW ECO^{Plus} hub system, 2003 -	
										ECO Plus 2	Weight-optimized axle with BPW ECO Plus 2 hub system, 2007 -	
										ECO Plus 3	Weight-optimized axle with BPW ECO Plus 3 hub system, 2015 -	
										MAXX	Weight-optimized axle with conventional hub bearing system	

Explanation of BPW code numbers

Mechanical suspensions series W / BW / GW (extract)

Example:							
32.	14.	743.	000				
				1. + 2. digit			
22.				Tandem axle assembly			
32.							
				3. + 4. digit			
		Axle load	Roller bearings	Axle series	Year of manuf.	Remark	
08.	09.	8000 - 9000 kg	33116 / 32310	H.. / K.. / N..	1982 -	Conventional hub bearing system	
10.		10000 - 12000 kg	33118 / 33213	H.. / K.. / N..	1982 -		
14.		13000 - 14000 kg	32219 / 33215	H.. / K.. / N..	1983 -		
16.		16000 - 18000 kg	32222 / 32314	H..	1983 -		
20.		20000 kg	32224 / 32316	H..	1983 -		
37.	38.	39.	8000 - 9000 kg	33116 / 32310	H.. / K.. / N..	1991 (1992) -	ECO / ECO-MAXX Unit
40.	41.		10000 - 12000 kg	33118 / 33213	H.. / K.. / N..	1991 (1992) -	
44.			13000 - 14000 kg	32219 / 33215	H..	1994 -	
48.			8000 - 9000 kg	33118 / 33213	H..		
50.	51.		10000 - 12000 kg	33118 / 33213	H.. / SH..; KH.. / SKH..; NH..	2000 -	ECO ^{Plus} Unit
58.	59.		8000 - 9000 kg	33118 / 33213	H.. / SH..; KH.. / SKH..; NH..	2007 -	ECO Plus 2 Unit
68.			8000 - 9000 kg	33118 / 33213	H.. / SH..; KH.. / SKH..; NH..	2015 -	ECO Plus 3 Unit
72.		12000 kg	32222 / 32314 32219 / 33215 33118 / 33213	EH.. 12000 EH.. 12000-1 EH.. 12000-2		Conventional hub bearing system	
73.		13000 / 14000 kg	32219 / 33215	EH.. 13000-1 EH.. 14000-1			
74.		14000 kg	32222 / 32314	EH.. 14000			
76.		9000 kg	33215 / 32310	EH.. 9000			
80.		11000 kg	33217 / 33213	EH.. 11000			
85.		8000 kg	33215 / 32310	EH.. / ZR..	1967 - 1982		
86.		10000 kg	33217 / 33213	EH.. / ZR..	1966 - 1982		
87.		20000 kg	32224 / 32316	EH..	- 1983		
89.		16000 kg	32222 / 32314	EH..	- 1983		
				5. - 7. digit			
501.	-	839.	Designation of wheel brake in the case of ref. number 20... - 39...				
			For explanation of code number, see EL-HKN / EL-TSB / BPW code number designation				
				8. - 10. digit			
000				Consecutive number 000 - 999			

Explanation of BPW code numbers

BPW Type plate

W
BW
GW

Riveted type plate up to year of manufacture 1999

Labels: Axle type, BPW Code number, Date and serial number, Brake type, Certificate type, Test report no.

Plate text: **BPW BERGISCHE ACHSEN KG** D 51674 WIEHL GERMANY
 30.38.743.000 // 954951842
 HSF 9010 ECO SN 4218
 zul. Achslast perm. axle capacity charge adm. STAT. 9000 v max. km/h max. speed vitesse maxi. 105
 TYP S 90 TDB 00 07

Max. static axle load on ground
 "Permissible techn. axle load"
 = Test load of wheel brakes

Labels: Achsl. kg, km/h

Plate text: 30.85.823.007 8255
 EHSD 8010
 Achsl. kg 8000 km/h 80
 Dauerbremse nach § 41/15 StVZO

Exec. prior to 1981

Adhesive type plate from year of manufacture 2000

Plate text: **BPW BERGISCHE ACHSEN KG** D-51674 Wiehl Germany
 HSF 9010 ECO SN 4218
 30.38.743.000 Bj. 993110227
 TYP S 90 TDB 00 07
 zul. Achslast perm. axle capacity charge adm. stat. 9000 kg 105 km/h

Type plate from year of manufacture 2006 (Adhesive type plate) with barcode

Plate text: **BPW BERGISCHE ACHSEN KG** Made in Germany
 HSF 9010 ECO-P SN 4218 073110227
 S90TDB0007 / S100-1TDB0014 / H102TDB0752
 27.58.743.000 zul. Achslast perm. axle capacity charge adm. stat. 9000 kg 105 km/h

BPW Type designations	Example:
The BPW type name is composed of a letter group and a number group.	HSF 9010 ECO-P
The letter group identifies the type of axle and suspension version as well as defining the hub version.	HSF - BPW axle series H for single wheels (without offset), wheel studs M 22 x 1.5, without wheel nuts
The number group specifies the axle load on the ground in kilogrammes and the number of wheel studs per wheel hub (for disc wheel connection).	9010 - 9000 kg axle load - 10 wheel studs per wheel
The group of letters at the end of the model name defines the type of hub bearing.	ECO-P - ECO^{Plus} bearing generation
You can view the brake certificate referenced by certificate type/test report number on the type plate by logging onto the BPW website at www.bpw.de (Download Centre in the German version of the website - „Bremsgutachten“).	e.g. S 90/.../TDB 00 07 - S 90 Certificate type - TDB 00 07 Test report no.

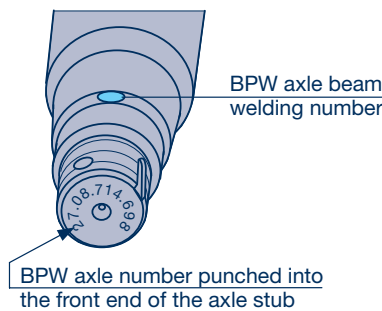

The BPW axle code number is shown on the type plate.

If this is missing or no longer legible, the BPW axle number can be read off the front end of the axle stub in most cases.

In steering axles and ECO Plus 2 bearings, there is no code number embossed on the front end of the stub.

From June 2012, the axle beam welding number will now be stamped onto the axle stub on the front.

Where the axle beam welding number is indicated, the axle can also be identified. See also BPW Internet application for spare part lists for commercial vehicles.

Notes

W

BW
GW

Mechanical suspensions series W

General

BPW W-units for tropical and arctic off-road applications.

For transporting robust goods on roads, off-road and on construction sites.

W-units designed by BPW for tandem axles are extremely well suited to use under even the harshest conditions.

Whether on or off-road, on construction sites, in the arctic or in the tropics – these robust and long-lasting multiple leaf spring suspension systems ensure reliable goods transport.

They operate purely mechanically. For example, they can easily be repaired even if the infrastructure is underdeveloped.

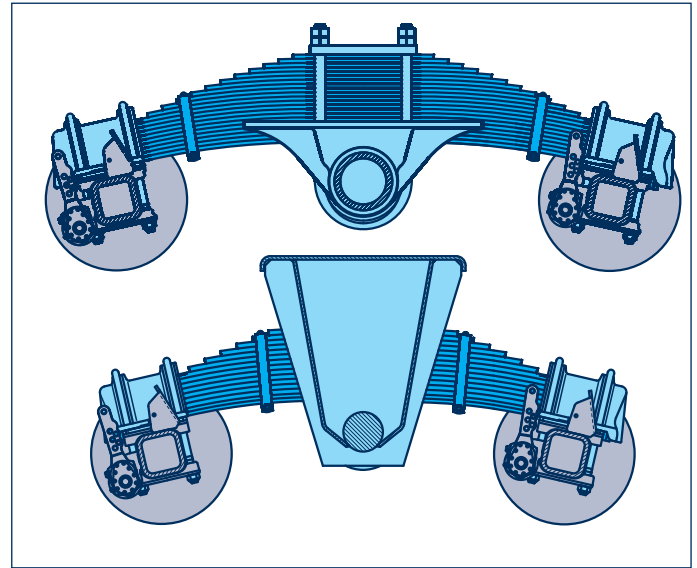

Description

BPW W-unit with low mounting brackets

- ⊙ For axle loads from 2 x 8t to 2 x 20t
- ⊙ Delivered as ready-to-fit, completely assembled unit
- ⊙ Proven for many years in harsh off-road and tipper applications
- ⊙ Constructed with a high level of lateral stability
- ⊙ Equipped with robust and long-life multi-leaf springs
- ⊙ Very long axle load equalization distances
- ⊙ Not sensitive to semitrailer tilt
- ⊙ Insensitive to heat, cold and dirt
- ⊙ High-quality mounting of the trunnion axle in bronze / composite bearing material bushes
- ⊙ Simple installation to the vehicle frame using bolt connection

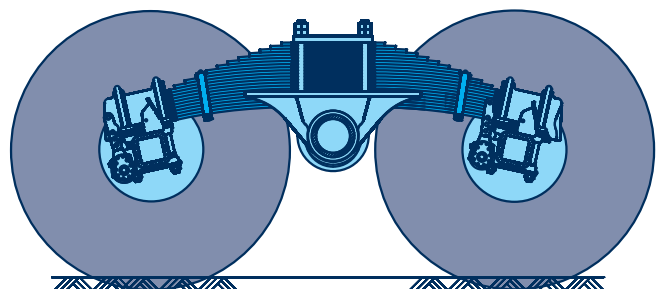
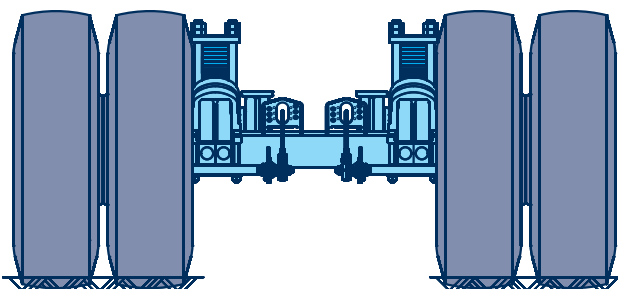
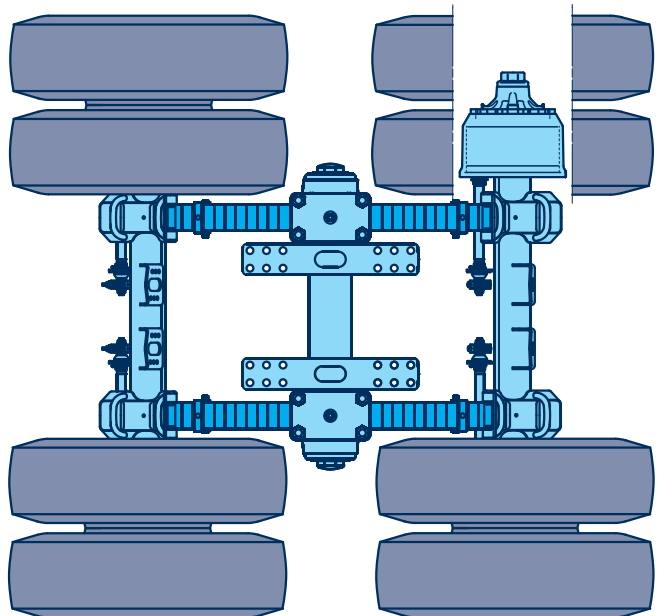

Mechanical suspensions series W

General

Function

Whenever you need the ruggedness to cope with high axle loads under difficult operating conditions, choose leaf-sprung tandem axle units with an intermediate pivoting trunnion axle for holding the frame connecting pieces.

The spring packs are extremely sturdy and comprise several spring steel layers. They are mounted in swinging bearings on the trunnion axle using bronze / composite bearing material bushes. The axles are clamped onto the spring ends and are controlled by the offset main spring layers.

An even distribution of tension across the length of the spring is achieved thanks to the use of spring layers with different lengths. This produces a trapezoidal shape in the side view, which explains why the arrangement is also referred to as a trapezoidal spring. Two low supports between the springs are used for attachment below the vehicle, or a tall central block provides for direct mounting on the vehicle frame.

W

Description

BPW W-unit with tall bearing blocks

- ⦿ For axle loads from 2 x 8t to 2 x 20t
- ⦿ Delivered as ready-to-fit, completely assembled unit
- ⦿ Proven for many years in harsh off-road and tipper applications
- ⦿ Constructed with a high level of lateral stability
- ⦿ Equipped with robust and long-life multi-leaf springs
- ⦿ Very long axle load equalization distances
- ⦿ Not sensitive to semitrailer tilt
- ⦿ Insensitive to heat, cold and dirt
- ⦿ High-quality mounting of the trunnion axle in bronze / composite bearing material bushes
- ⦿ Simple installation to the vehicle frame using bolt connection

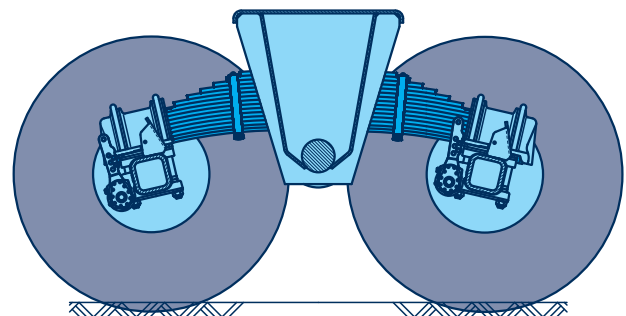
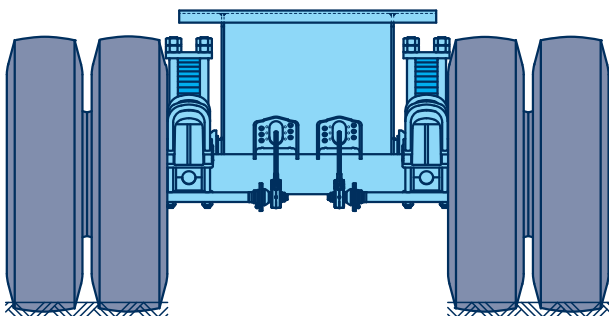
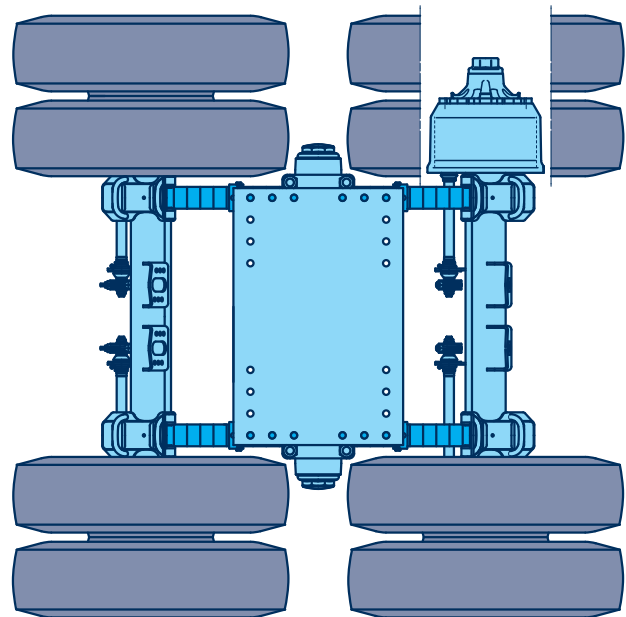

1 Leaf springs for suspensions series W

1.1 General

BPW W-units are equipped with multi-leaf springs.

Multi-leaf springs (trapezoidal springs) contain a stack of spring layers with different cross-sections and graded lengths to give a trapezoidal shape.

They are characterised by their robustness and good default driving properties as well as the ease of replacing individual spring layers.

The spring ends of the leaf springs are connected to the axles with spring U-bolts.

As a load-bearing component of the suspension unit, the leaf spring requires particular attention.

The following instructions should be carefully adhered to during repair and maintenance work:

- ⦿ Do not work on leaf springs with a hammer or any sharp objects.
- ⦿ Do not work on leaf springs with cutters or grinders.
In the event that replacement springs or leaves do not fit exactly into the seat of the spring pads or spring housing, the mounting seat must always be widened.
- ⦿ Individual leaves can be replaced in multi-leaf springs.

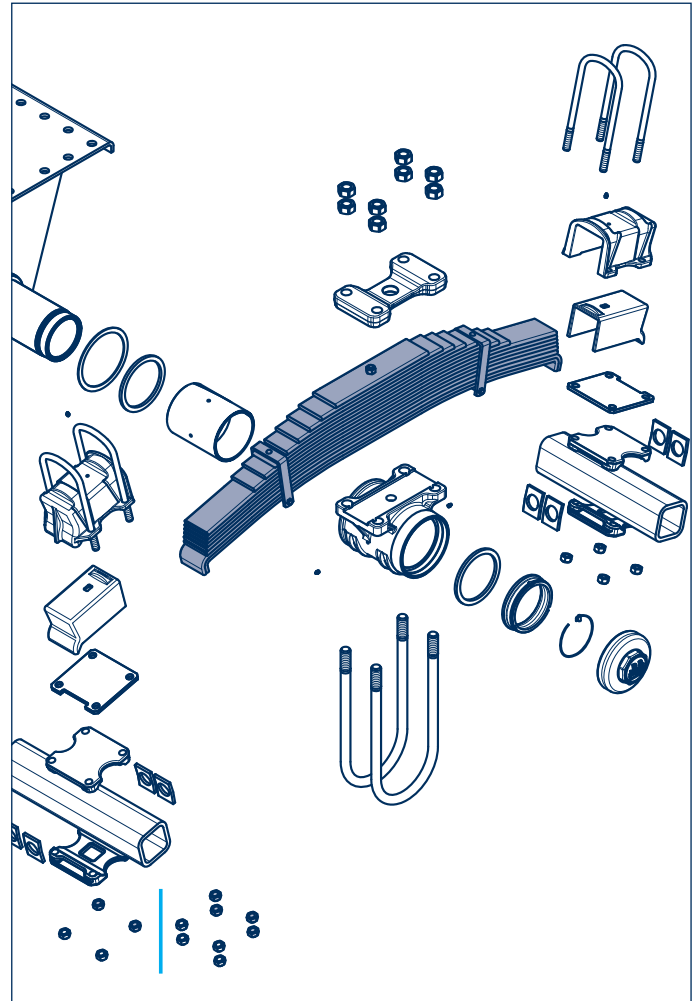

Important for all welding work!

The leaf springs, plastic pipings and other sensitive parts should be protected against sparks and weld splashes during all welding work.

The earth terminal must under no circumstances be attached to the leaf spring or hub.

Leaf springs for suspensions series W 1

General 1.1

BPW Code number

The BPW code number of the leaf spring is stamped into the spring shackle.

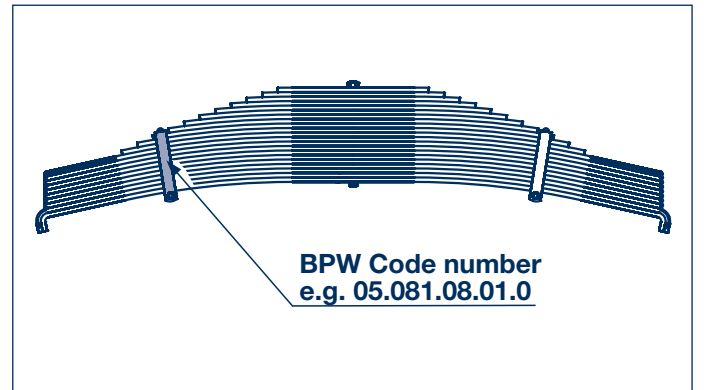

Leaf springs with safety catch

With a catch device, the lowest layer of the leaf springs is rolled in at the ends and is connected at the axle connection using shackles and bolts as well as an additional spring clamp.

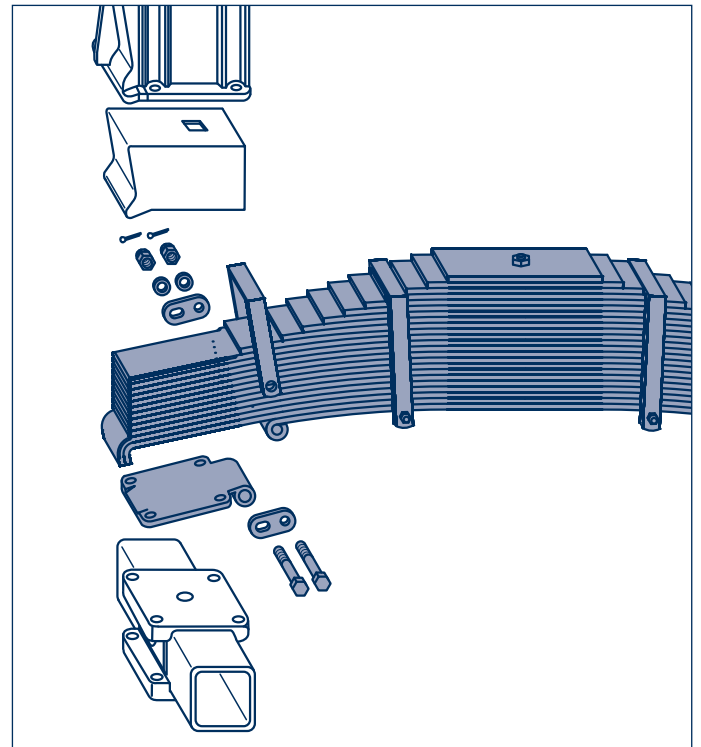

Further information, along with installation and safety instructions, can be found in our current workshop manuals.

1 Leaf springs for suspensions series W

1.2 Leaf springs

H = Leaf spring height

FB = Leaf spring width

L = Leaf spring length

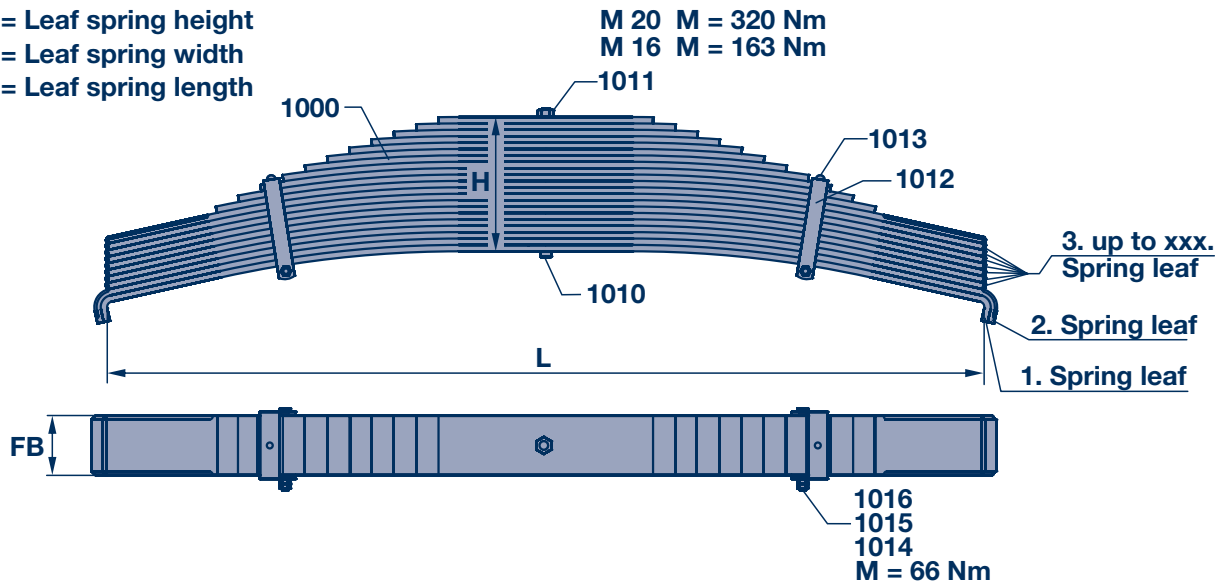

Qty. Layer	Wheel base	Axle load	L	H	FB	BPW Code no. Leaf spring Item 1000	Spring leaves
15	1500	16 - 18t	1820	272	120	05.081.08.32.0	1. upon request 2. upon request 3.-7. upon request
17	1550	16 - 18t	1820	302	120	05.081.08.07.0	1. 02.1012.08.86 2. 02.1012.08.87 3.-4. 02.1012.08.88
	1550	18 - 20t	1820	302	120	05.081.08.13.0	1. 02.1013.08.33 * 2. 02.1013.08.34 3.-4. 02.1013.08.35
	1550	18 - 20t	1820	308	120	05.081.08.33.0	1. upon request * 2. upon request 3.-7. upon request
18	1400	11 - 12t	1640	298	90	05.081.08.18.0	1. 02.1013.08.77 2. 02.1013.08.78 3.-8. 02.1013.08.79
	1500	11 - 12t	1740	216	90	05.081.07.12.0	1. 02.1013.08.56 2. 02.1013.08.57 3.-8. 02.1013.08.58
19	1500	13 - 14t	1770	266	120	05.081.08.04.0	1. 02.1013.08.01 2. 02.1013.08.02 3.-9. 02.1013.08.03
21	1500	14t	1920	294	120	05.081.08.01.0	1. 02.1012.08.20 2. 02.1012.08.21 3.-9. 02.1012.08.22
Further types upon request.							Further spring leaves upon request. * = with riveted plates

Leaf springs for suspensions series W 1

Spare parts for leaf springs 1.3

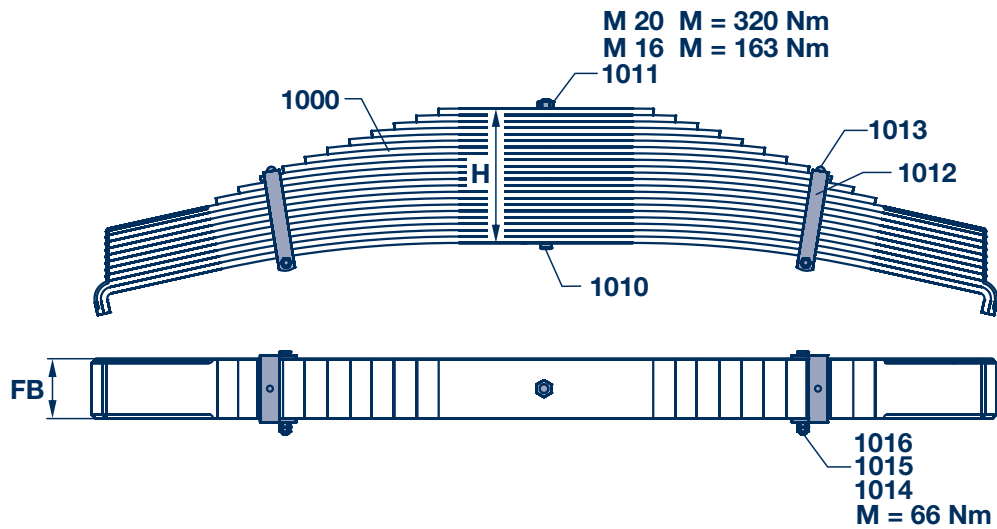

	Item	Designation	Leaf spring thickness H	Dimension (A)	BPW Code no.
	1010	Spring screw	216	AM 16 x 235-8.8	upon request
			236	AM 16 x 255-8.8	02.5038.67.80
	1010	Spring screw	275	AM 16 x 295-8.8	02.5038.60.80
			284	AM 16 x 300-8.8	upon request
			298	AM 16 x 315-8.8	02.5038.65.80
			300	AM 16 x 320-8.8	upon request
			310	AM 16 x 330-8.8	upon request
			332	AM 16 x 350-8.8	02.5038.66.80
			350	AM 16 x 370-8.8	02.5038.64.80
			238	AM 20 x 2 x 260-8.8	upon request
			248	AM 20 x 2 x 270-8.8	02.5038.73.80
			266	AM 20 x 2 x 290-10.9	02.5038.77.10
			272	AM 20 x 2 x 300-8.8	upon request
			294	AM 20 x 2 x 315-8.8	02.5038.71.80
			302	AM 20 x 2 x 325-8.8	02.5038.72.80
			308	AM 20 x 2 x 335-8.8	upon request
398	AM 20 x 2 x 420-8.8	02.5038.75.80			
410	AM 20 x 2 x 430-8.8	02.5038.76.80			
	1011	Hexagon nut		M 16 / 934-8 M 20 x 2 / 934-8	02.5202.20.80 02.5202.33.80
	1012	Spring clamp	FB = 90 FB = 120	C 90 x ... C 120 x ...	upon request
	1013	Button head rivet		12 x .. / 124	
	1014	Hexagon bolt	FB = 90 FB = 120	M 12 x 130 M 12 x 160	
	1015	Lock nut (1x) Hexagon nut (2x)		VM 12 / 980-8 M 12 / 934-8	02.5220.14.82 02.5202.16.80
	1016	Tube	FB = 90 FB = 120	Ø 14 / 18 x 94 Ø 14 / 18 x 124	upon request

2 Axle clampings

2.1 General

Axle – leaf spring connection

The axle is connected to the leaf spring using the axle connection comprising: spring U-bolts, spring housing, spring cushions, spring pads, etc..

The (rubber) spring cushion inserted in the spring housing prevents vibration and helps to cushion shocks.

The bent-over spring ends are located in the recess in the plates (item 1040) arranged on the spring pads. In many leaf springs, these plates are riveted onto the lowest spring layer.

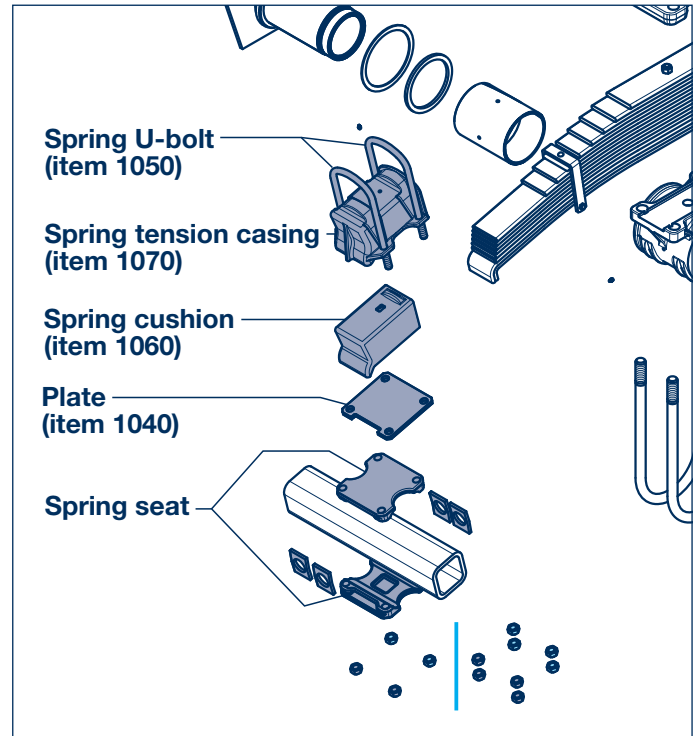

Axle alignment

After repairs have been carried out on the axle beam, connecting piece, connecting rods etc., the axle alignment must be checked and if necessary corrected.

Determine the diagonal dimensions **A - B** and **A - C** for the centre axle (reference axle) by means of comparative measurements (± 2 mm tolerance).

Check and if necessary correct the wheel base dimensions **B - D** and **C - E** for the rear axle (max. tolerance ± 2 mm).

In case of deviations, the parallel arrangement of the axles must be achieved by welding on the upper spring pads.

Measurement is generally carried out by means of the hub cap centre point (see illustration) or the centring hole in the axle stub.

It can also be carried out using screwed-on graduated tubes.

Hub cap centre point in the BPW logo.

The triangle (\triangle) in the BPW logo is positioned centrally if there is an $\text{\textcircled{R}}$ or ECO (ECO^{Plus}) stamped below the BPW logo (since 1989/1994).

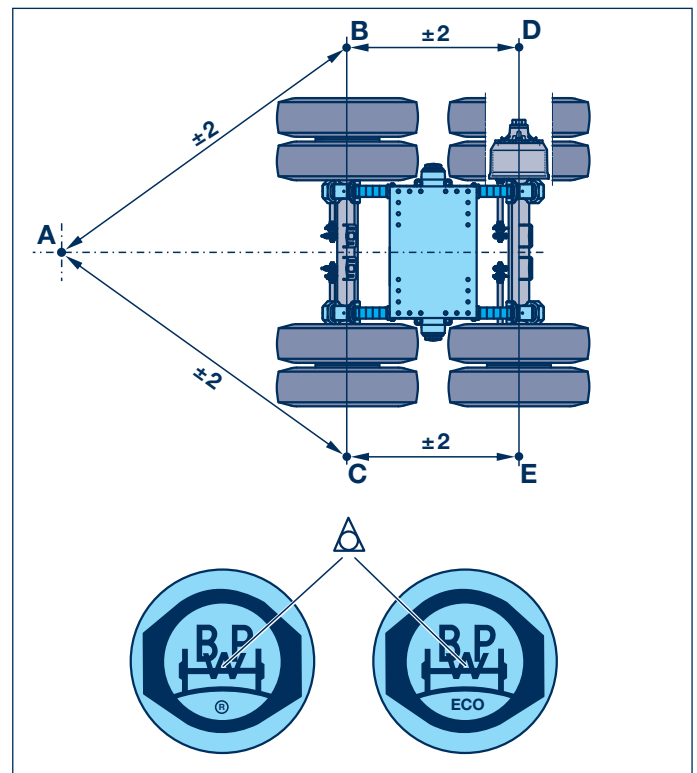

Axle clampings 2

General 2.1

Welding guidelines for axle beams

When fitting or repairing trailer axles it may be necessary to weld components onto the axle beam.

For that reason BPW axles are made of materials that can be welded. The axle beams do not have to be pre-heated before welding.

The carrying capacity and faultless operation of BPW axles are not impaired by welding, if the following points are complied with.

Welding process

- ⊙ Inert gas-shielded arc welding
Welding wire quality G 42 0 (DIN EN 440)
- ⊙ Manual arc welding
Stick electrodes E 42 2 (DIN EN 499)

Mechanical quality values must correspond to the basic material S 355 J 2 or S 420.

Max. weld thickness a 5 Δ (DIN EN 25817)

Avoid end craters and undercuts.

Miscellaneous

No unauthorised change to the camber angle of the axle.
Adherence to the welding zones and weld lengths as shown in the adjacent sketch.

👉 **No welding must be carried out in the lower tensile zone of the axle beam!**

👉 **Important for all welding work!**

The leaf springs, plastic pipings and other sensitive parts should be protected against sparks and weld splashes during all welding work.

The earth terminal must under no circumstances be attached to the leaf spring or hub.

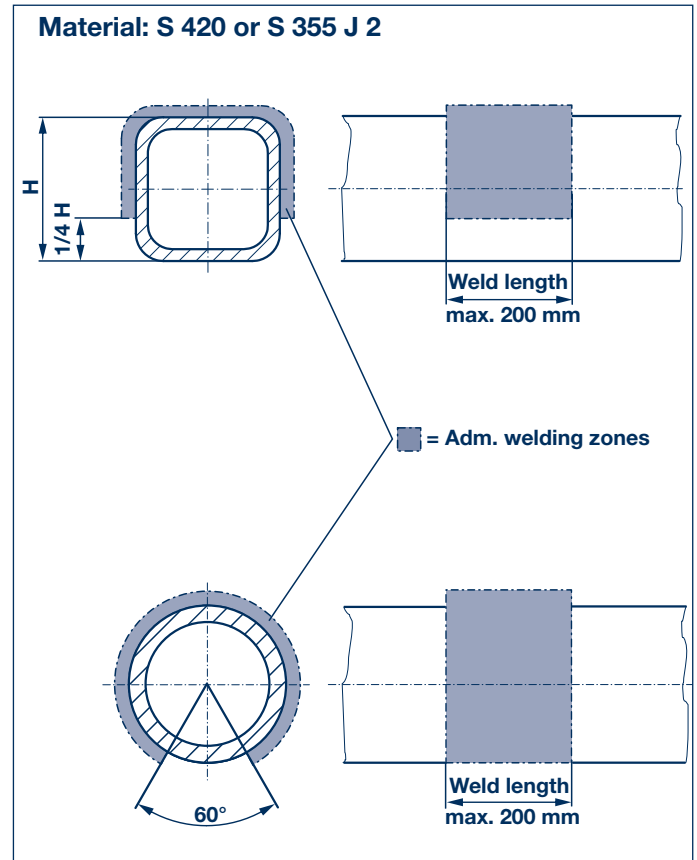

2 Axle clampings

2.2 Spring seats, axle clamping, safety catch

Spring seats, axle clamping, safety catch

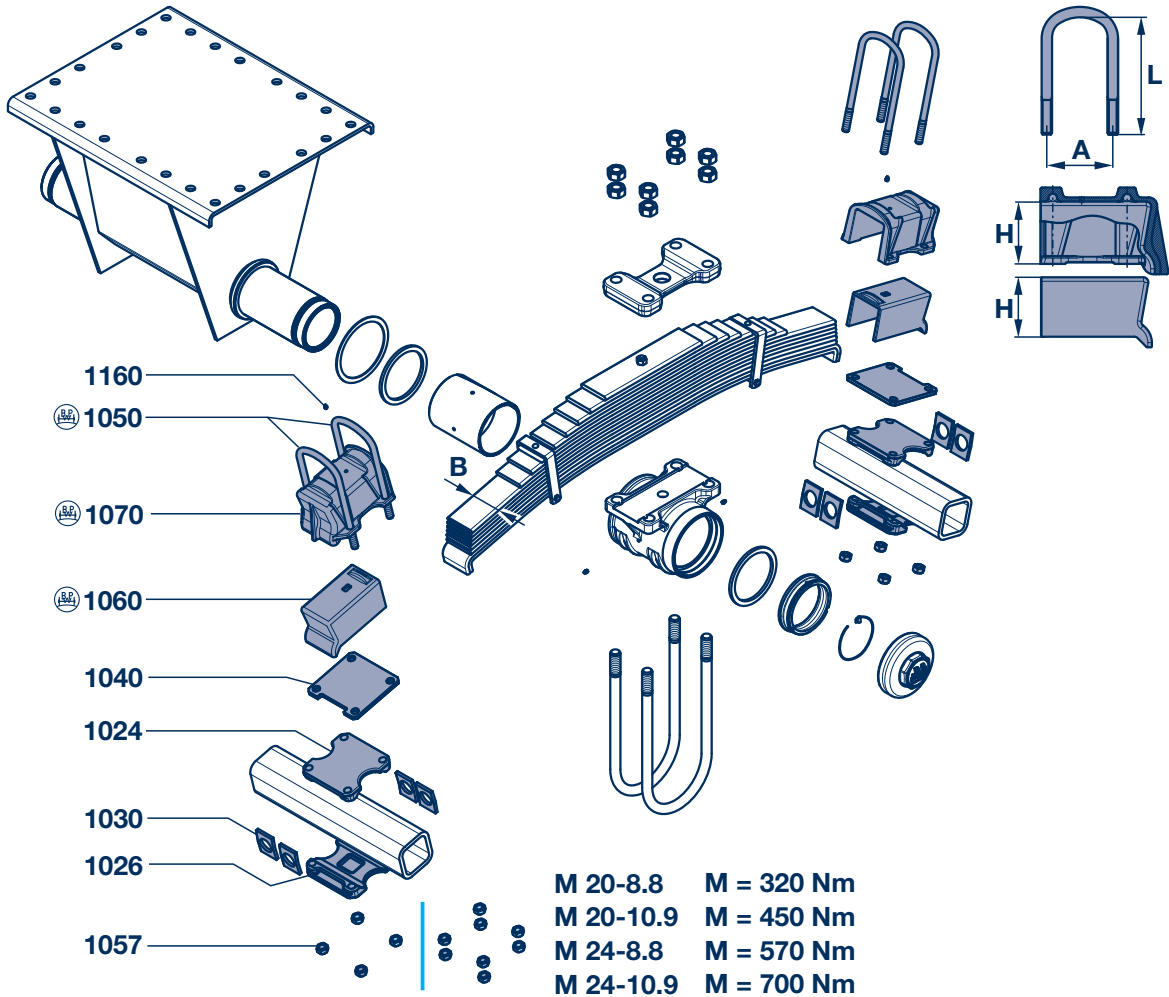

Leaf springs with riveted plates

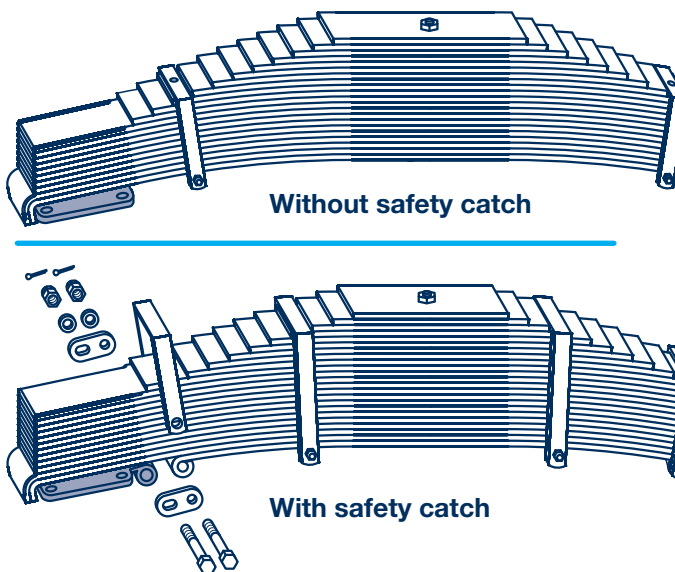

Leaf springs with safety catch

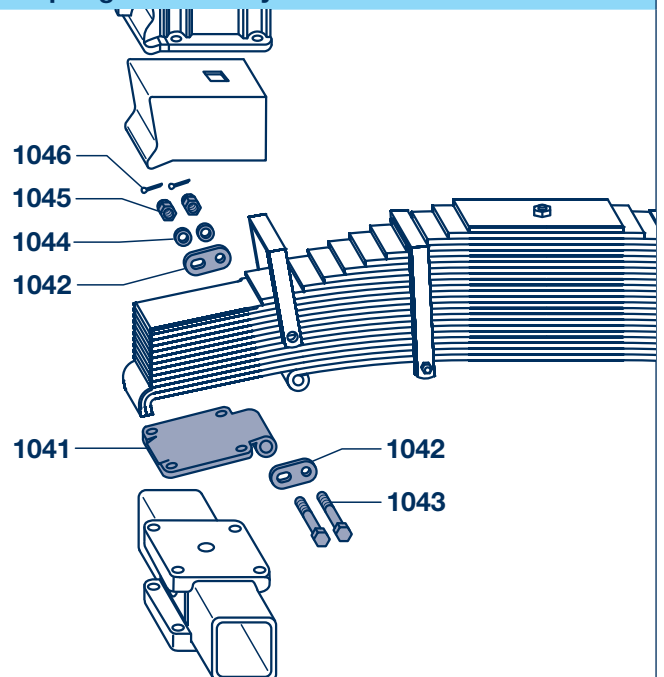

Axle clampings 2

Spring seats, axle clamping, safety catch 2.2

Spring seats					
Item	Designation	BPW Code no.			
		Leaf spring width (B) = 90 mm			Leaf spring width (B) = 120 mm
		8 - 12t Ø 127	8 - 9t □ 120	10 - 12t □ 150	10 - 20t □ 150
1024	Spring seat, upper	03.032.38.65.0 4x	03.032.17.63.0 2x	03.032.19.24.0 2x	03.032.19.32.0 2x
1026	Spring seat, lower	-	03.032.17.06.0 2x	03.032.19.23.0 2x	03.032.19.34.0 2x
1030	Shaped plate	-	03.161.64.06.0 4x	03.161.64.07.0 4x	03.161.64.05.0 8x
Axle clamping					
Item	Designation	Dimension	BPW Code no.		
			8 - 10t B = 90	10 - 12t B = 90	12 - 20t B = 120
1040	Plate	200 x 180 x 12	03.285.76.07.0	-	-
		224 x 200 x 12	-	03.281.76.03.0 *	-
		240 x 234 x 12	-	-	03.285.76.01.0
1050	Spring U-bolt	M 20 / A 133 / L 332	03.138.34.02.4	-	-
		M 20 / A 133 / L 346	03.138.34.03.4	-	-
		M 20 / A 152 / L 405	03.138.37.01.0	-	-
		M 24 / A 152 / L 415	-	03.138.41.29.4 ¹⁾	-
		M 24 / A 192 / L 415	-	-	03.138.42.01.4 ¹⁾
1057	Hexagon nut (32x)	M 20-10.9 / 934	02.5202.24.10	-	-
		M 24-10.9 / 934	-	02.5202.30.10	02.5202.30.10
	Lock nut (16x)	VM 24-10.9 / 980	-	02.5220.74.12	02.5220.74.12
1060	Spring cushion	H = 103	03.140.14.02.0	-	-
		H = 151	03.140.14.01.0	03.140.14.01.0	-
		H = 147	-	-	03.140.16.01.0
1070	Spring tension casing	H = 106	03.146.03.02.0	-	-
		H = 155	03.146.03.06.0	03.146.06.06.0	-
		H = 151	-	-	03.146.06.05.0
1160	Grease nipple	AS 10 x 1	02.6850.06.02		
* Not with leaf springs with riveted plates					
¹⁾ Important! Short spring U-bolts, use only lock nuts (02.5220.74.12)					
Safety catch					
Item	Designation	Dimension	BPW Code no.		
Leaf springs with safety catch			B = 90		
1041	Locking plate		03.351.00.07.0		
1042	Shackle		03.232.74.02.0		
1043	Hexagon screw	M 20 x 160	02.5023.09.82		
1044	Washer	Ø 20 / 1440	02.5407.20.01		
1045	Castle nut	M 20 / 937	02.5207.18.04		
1046	Split pin	Ø 4 x 36 / 94	02.6201.44.01		

3 Trunnion axle, trunnion axle bearings

3.1 General

Trunnion axle beam

The trunnion axle consists of a thick-walled tube to which are attached two low supports for attachment below the vehicle, or a tall central block between the springs provides for direct mounting to the vehicle frame.

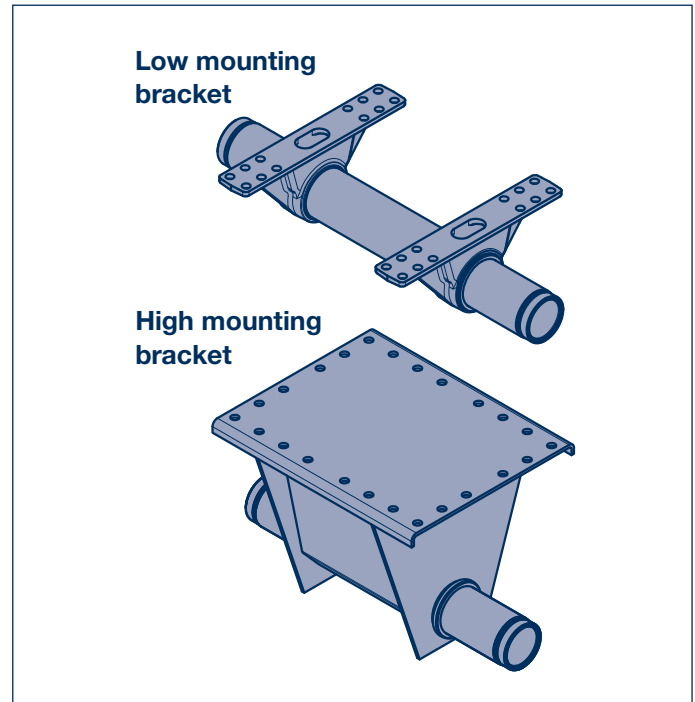

Trunnion axle – leaf spring connection

The leaf spring axle is connected to the trunnion axle beam using the trunnion axle connection comprising: spring U-bolts, mounting brackets, spring plates, etc..

The generously sized bronze / composite bearing material bushes in the mounting brackets ensure a low-maintenance, long-lasting mounting.

Grease nipples attached to the mounting brackets permit straightforward greasing of the bearing points.

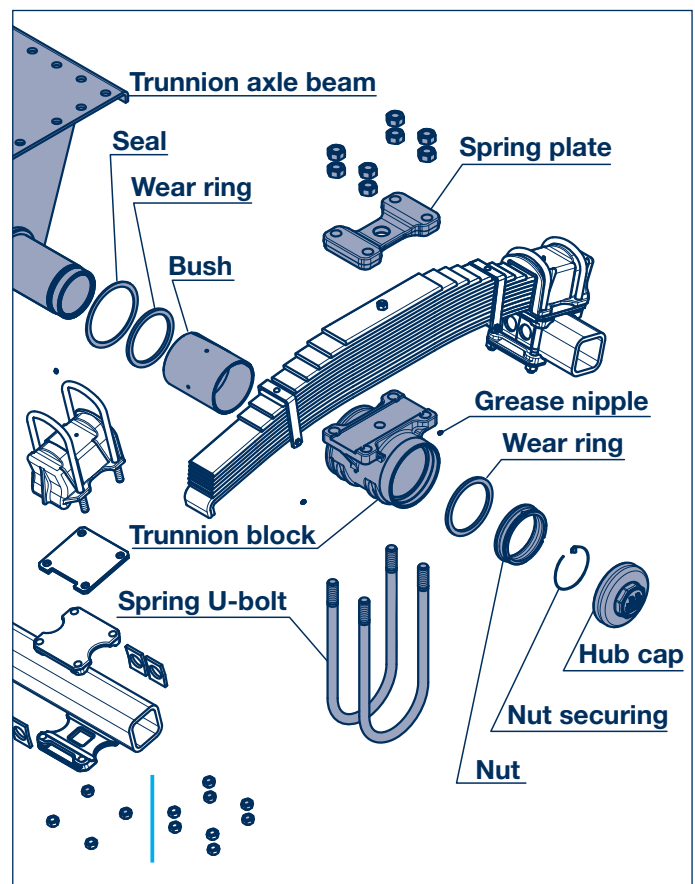

Trunnion axle, trunnion axle bearings 3

General 3.1

Trunnion axle bearing

The axle support bearing consists of bronze / composite bearing material bushes equipped with lubrication holes and ducts.

A sealing ring on the side facing the middle of the vehicle prevents dirt and dust from penetrating.

On the side facing the outside of the vehicle, a screwed-in hub cap prevents foreign bodies from penetrating.

If necessary, the closing rings and bronze / composite bearing material bushes can be changed in a straightforward procedure.

The slotted nuts bolted onto the ends of the trunnion axle beam are secured with hooked spring rings and pins to prevent them coming loose.

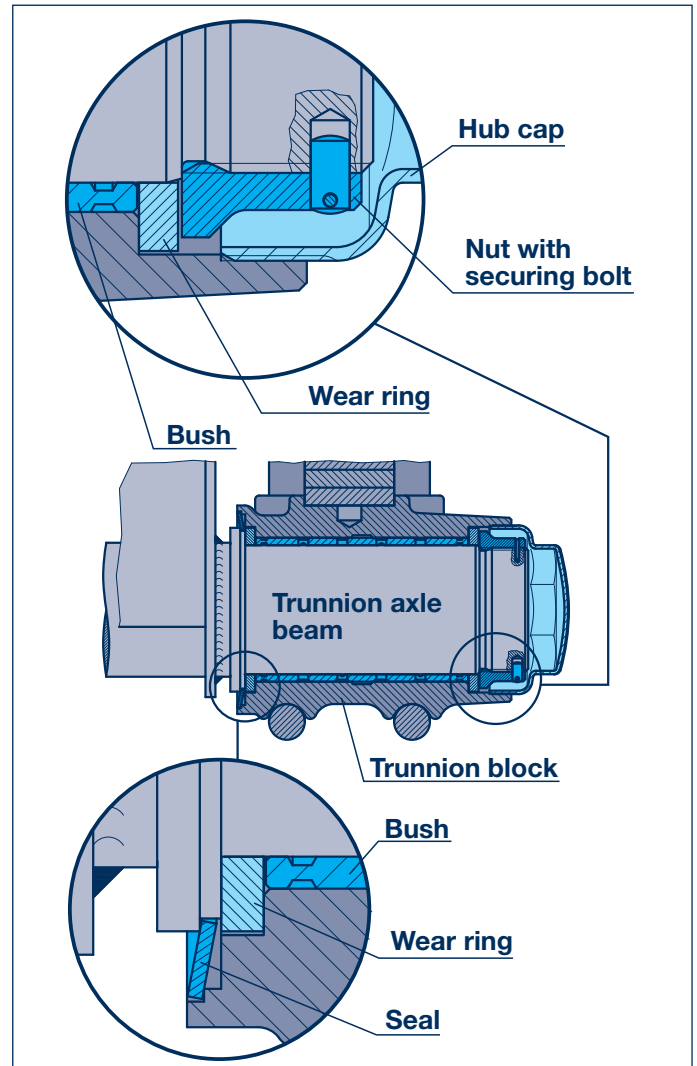

3 Trunnion axle, trunnion axle bearings

3.2 Trunnion axle bearing

Trunnion axle bearing

W

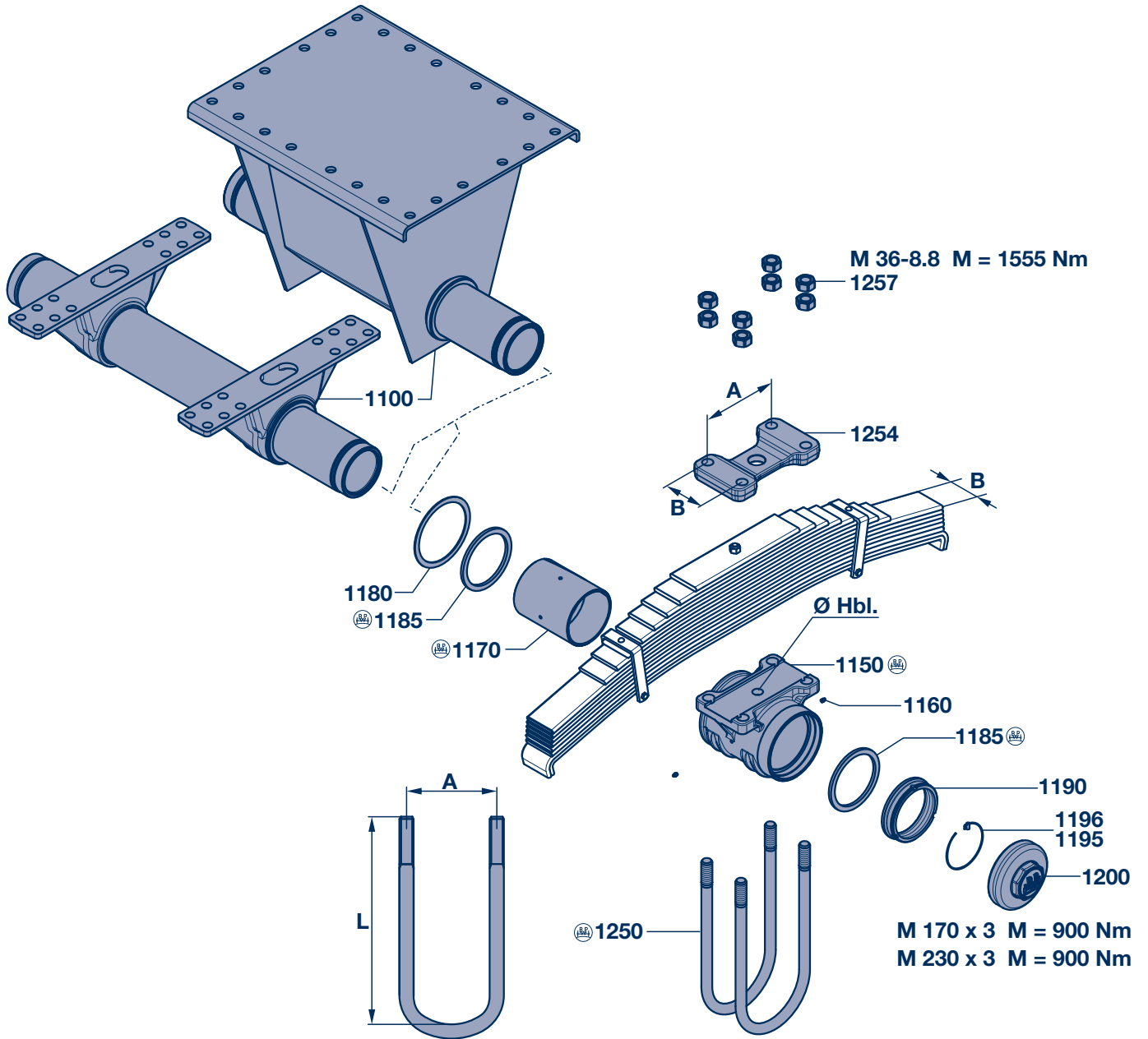

Trunnion axle, trunnion axle bearings **3**

Trunnion axle bearing **3.2**

Trunnion axle bearing					
Item	Designation	Dimension	BPW Code no.		
			8 - 12t B = 90	(12 t) 14 t (16 t) B = 120	16 - 20t B = 120
1100	Trunnion axle beam		When ordering trunnion axle beam please state suspension type and BPW code-no. (name plate).		
1150	Trunnion block	Ø 145 / Hbl. Ø 24	03.224.17.01.1	-	-
		Ø 200 / Hbl. Ø 24	-	03.224.19.02.1	-
		Ø 200 / Hbl. Ø 35	-	-	03.224.19.03.1
1160	Grease nipple	AS 10 x 1	02.6850.06.02		
1170	Bush	Bronze Ø 130 / 145 x 214	03.112.99.02.0	-	
		Composite material Ø 185 / 200 x 243	-	03.112.99.18.0	
1180	Ring	Ø 160 / 196 x 3.5	03.310.88.03.0	-	
		Ø 214 / 250 x 3.5	-	03.310.89.08.0	
1185	Ring	Ø 130 / 165 x 10	03.310.38.01.0	-	
		Ø 185 / 220 x 10	-	03.310.39.02.0	
1190	Nut	M 125 x 4	03.264.19.02.0	-	
		M 180 x 4	-	03.264.19.03.0	
1195	Spring ring	Ø 119 x 3.2	03.188.06.04.0	-	
		Ø 159 x 3.2	-	03.188.07.04.0	
1196	Bolt	Ø 10 x 20	03.084.72.01.0		
1200	Hub cap	M 170 x 3 / SW 130	03.212.26.06.0	-	
		M 230 x 3 / SW 120	-	03.212.27.01.0	
1250	Spring U-bolt	M 36 / A 233 / L 498	03.138.60.02.0	-	
		M 36 / A 233 / L 520	03.138.60.07.0	-	
		M 36 / A 233 / L 558	03.138.60.03.0	-	
		M 36 / A 233 / L 568	03.138.60.11.0	-	
		M 36 / A 233 / L 585	03.138.60.04.0	-	
		M 36 / A 233 / L 600	03.138.60.10.0	-	
		M 36 / A 233 / L 625	03.138.60.12.0	-	
		M 36 / A 290 / L 590	-	03.138.61.05.0	
		M 36 / A 290 / L 613	-	03.138.61.01.0	
		M 36 / A 290 / L 623	-	03.138.61.15.0	
		M 36 / A 290 / L 627	-	03.138.61.04.0	
		M 36 / A 290 / L 640	-	03.138.61.17.0	
		M 36 / A 290 / L 649	-	03.138.61.02.0	
		M 36 / A 290 / L 670	-	03.138.61.07.0	
		M 36 / A 290 / L 676	-	03.138.61.18.0	
		M 36 / A 290 / L 725	-	03.138.61.08.0	
M 36 / A 290 / L 765	-	03.138.61.06.1			
M 36 / A 290 / L 780	-	03.138.61.09.0			
1254	Plate	A 233 / B 126 x 25	03.281.97.10.0	-	-
		A 290 / B 156 x 30	-	03.281.97.12.0	-
	Spring plate	A 290 / B 156 x 50	-	-	03.145.23.31.0
1257	Hexagon nut (16x)	M 36 / 934-8	02.5202.44.80		

Mechanical suspensions series BW / GW

General

BPW BW and GW-units for medium-duty off-road applications.

For transporting robust goods on roads, off-road and on construction sites.

BPW and GW-units designed by BPW for tandem axles are extremely well suited to use under medium-duty conditions.

Whether on-road, off-road or on construction sites – these robust and long-lasting multiple leaf spring suspension systems ensure reliable goods transport.

They operate purely mechanically. For example, they can easily be repaired even if the infrastructure is underdeveloped.

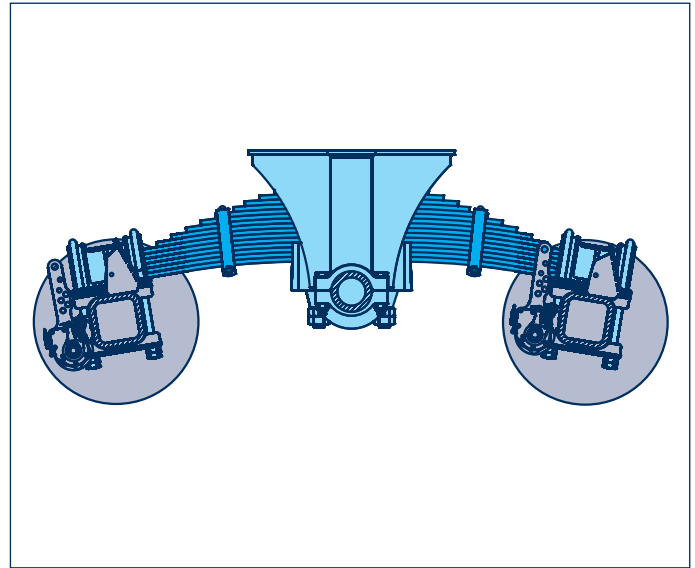

Description

BPW BW-unit (with bronze bushes)

- ⦿ For axle loads from 2 x 8t to 2 x 12t
- ⦿ Delivered as ready-to-fit, completely assembled unit
- ⦿ Proven for many years in harsh off-road and tipper applications
- ⦿ Constructed with a high level of lateral stability
- ⦿ Equipped with robust and long-life multi-leaf springs
- ⦿ Very long axle load equalization distances
- ⦿ Not sensitive to semitrailer tilt
- ⦿ Insensitive to heat, cold and dirt
- ⦿ High-quality mounting of the trunnion axle in bronze bushes
- ⦿ Simple installation to the vehicle frame using bolt connection

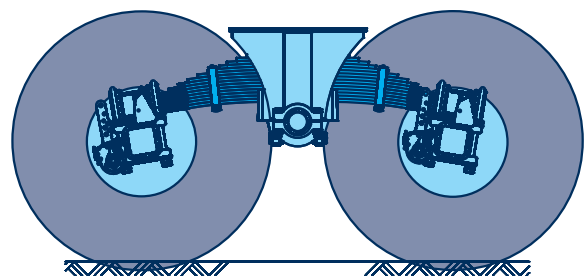
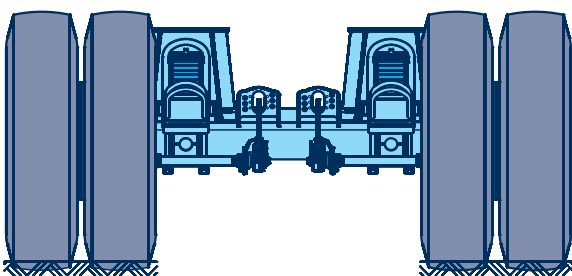
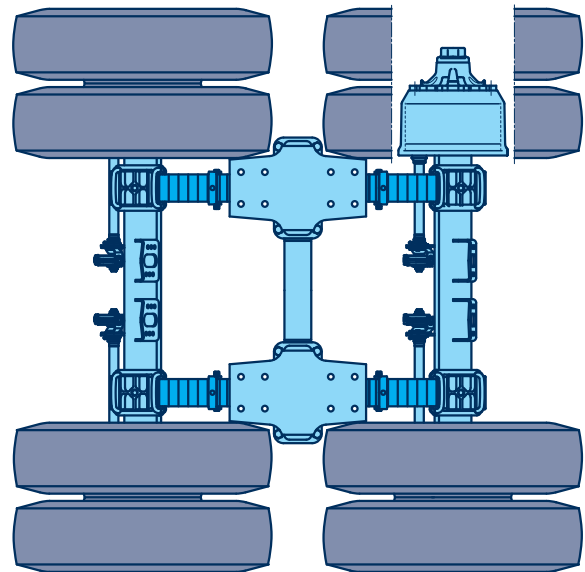

Mechanical suspensions series BW / GW

General

Function

Whenever you need to cope with high axle loads under difficult operating conditions, choose leaf-sprung tandem axle units with an intermediate pivoting trunnion axle for holding the frame connecting pieces.

The spring packs are extremely sturdy and comprise several spring steel layers. They are mounted in swinging bearings on the trunnion axle using bronze or rubber bushes. The axles are clamped onto the spring ends and are controlled by the main spring layers.

An even distribution of tension across the length of the spring is achieved thanks to the use of spring layers with different lengths. This produces a trapezoidal shape in the side view, which explains why the arrangement is also referred to as a trapezoidal spring. Two tall blocks for direct mounting on the vehicle frame are used for attachment under the vehicle.

BW
GW

Description

BPW GW-unit (with rubber bushes)

- ⊙ For axle loads from 2 x 8t to 2 x 10t
- ⊙ Delivered as ready-to-fit, completely assembled unit
- ⊙ Proven for many years in off-road and tipper applications
- ⊙ Constructed with a high level of lateral stability
- ⊙ Equipped with robust and long-life multi-leaf springs
- ⊙ Very long axle load equalization distances
- ⊙ Not sensitive to semitrailer tilt
- ⊙ Insensitive to heat, cold and dirt
- ⊙ Low-maintenance mounting of the trunnion axle in rubber bushes
- ⊙ Simple installation to the vehicle frame using bolt connection

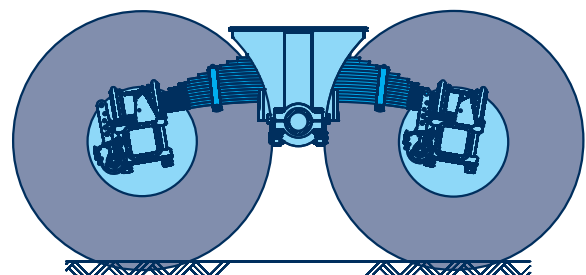
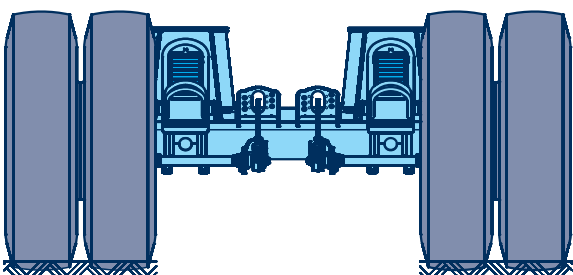
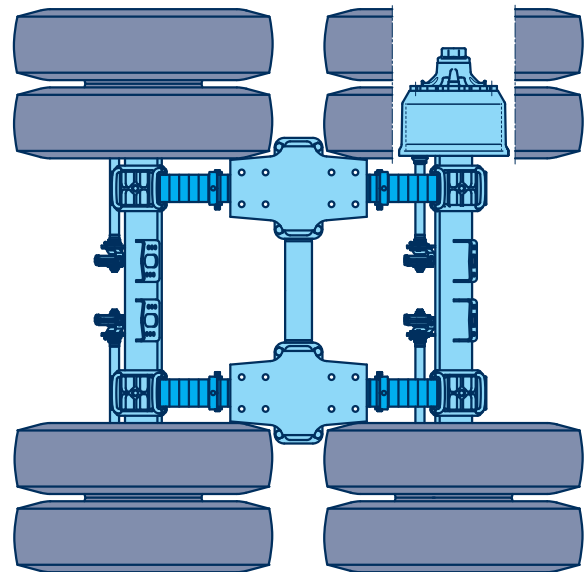

4 Leaf springs for suspensions series BW / GW

4.1 General

BPW BW and GW-units are equipped with multi-leaf springs.

Multi-leaf springs (trapezoidal springs) contain a stack of spring layers with different crosssections and graded lengths to give a trapezoidal shape.

They are characterised by their robustness and good default driving properties as well as the ease of replacing individual spring layers.

The spring ends of the leaf springs are connected to the axles with spring U-bolts.

The pins of the upper spring pads project into the two lower, drilled spring layers.

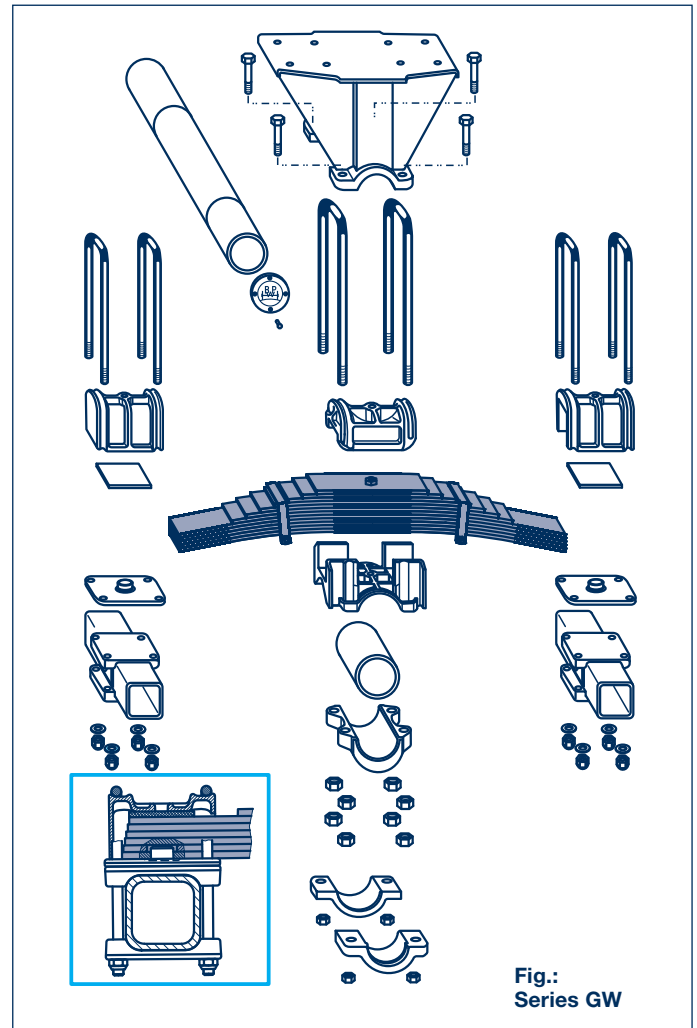

In many leaf springs, plates are riveted onto the lower spring layers.

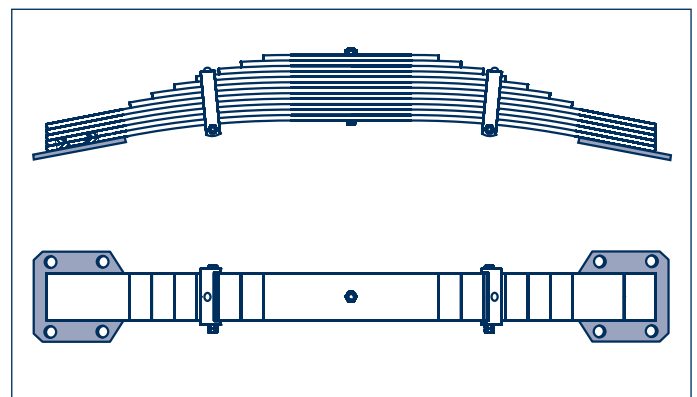

Leaf springs for suspensions series BW / GW 4

General 4.1

BPW Code number

The BPW code number of the leaf spring is stamped into the spring shackle.

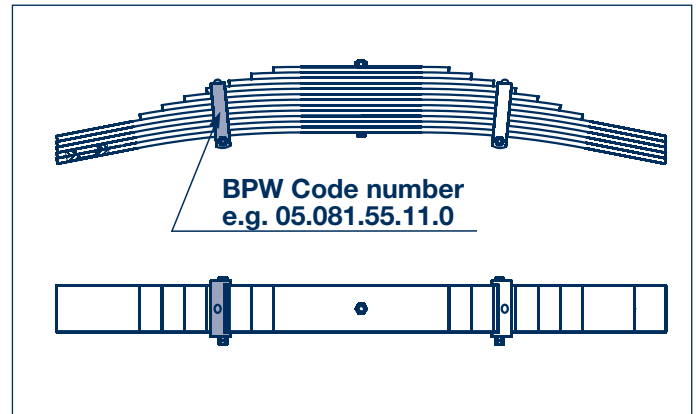

**BW
GW**

As a load-bearing component of the suspension unit, the leaf spring requires particular attention.

The following instructions should be carefully adhered to during repair and maintenance work:

- ⦿ Do not work on leaf springs with a hammer or any sharp objects.
- ⦿ Do not work on leaf springs with cutters or grinders.
In the event that replacement springs or leaves do not fit exactly into the seat of the spring pads or spring housing, the mounting seat must always be widened.
- ⦿ Individual leaves can be replaced in multi-leaf springs.

Important for all welding work!

The leaf springs, plastic pipings and other sensitive parts should be protected against sparks and weld splashes during all welding work.

The earth terminal must under no circumstances be attached to the leaf spring or hub.

Further information, along with installation and safety instructions, can be found in our current workshop manuals.

4 Leaf springs for suspensions series BW / GW

4.2 Leaf springs

BW
GW

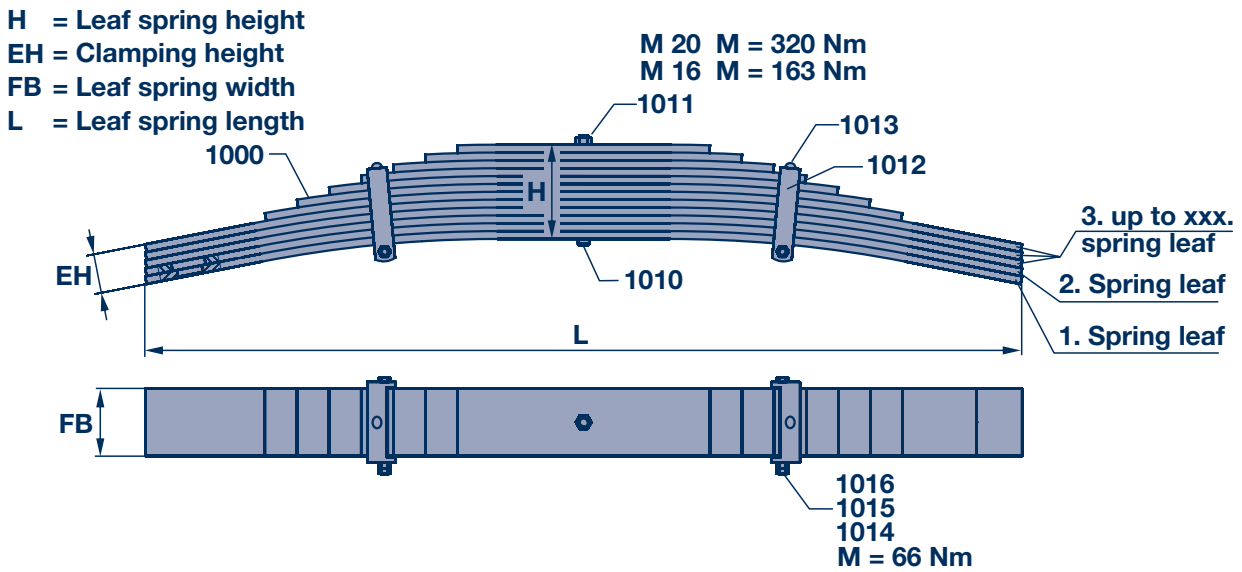

Qty. Layer	Wheel base	Axle load	L	H	FB	EH	BPW Code no. Leaf spring Item 1000	Spring leaves
11	1300	8t	1460	154	120	70	05.081.55.09.0	1. 02.1012.55.00 2. 02.1012.55.01 3.-5. 02.1012.55.02
12	1400	8t	1560	168	120	70	05.081.55.11.0	1. 02.1012.55.20 2. 02.1012.55.21 3.-5. 02.1012.55.22
13	1400	9t	1560	182	120	70	05.081.56.01.0	1. 02.1012.56.00 * 2. 02.1012.56.01 3.-5. 02.1012.56.02
15	1400	10t	1560	210	120	84	05.081.57.04.0	1. 02.1012.57.00 2. 02.1012.57.01 3.-6. 02.1012.57.02
	1400	11 - 12t	1590	228	120	84	05.081.58.03.0	1. 02.1012.58.00 * 2. 02.1012.58.01 3.-6. 02.1012.58.02
17	1500	16t	1690	296	120	96	05.081.58.04.0	1. 02.1012.58.36 * 2. 02.1012.58.37 3.-5. 02.1012.58.38
18	1400	14t	1590	252	120	96	05.081.58.06.0	1. 02.1012.58.51 * 2. 02.1012.58.52 3.-7. 02.1012.58.53
Further types upon request.								Further spring leaves upon request. * = with riveted plates

Leaf springs for suspensions series BW / GW 4

Spare parts for leaf springs 4.3

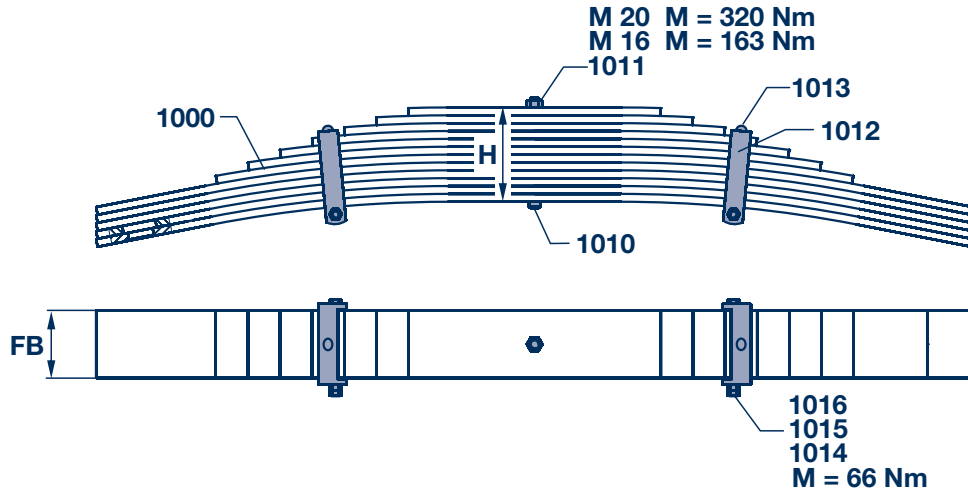

BW
GW

	Item	Designation	Leaf spring thickness H	Dimension (A)	BPW Code no.
	1010	Spring screw	154	AM 16 x 170-8.8	02.5038.51.80
			168	AM 16 x 185-8.8	02.5038.52.80
			182	AM 16 x 200-8.8	02.5038.61.80
			210	AM 16 x 225-8.8	02.5038.50.80
			228	AM 16 x 245-8.8	02.5038.58.80
			252	AM 20 x 2 x 275-8.8	upon request
			260	AM 20 x 2 x 280-8.8	02.5038.70.80
	1010	Spring screw	296	AM 20 x 2 x 315-8.8	upon request
			1011	Hexagon nut	M 16 / 934-8 M 20 x 2 / 934-8
	1012	Spring clamp	FB = 120	C 120 x ...	upon request
	1013	Button head rivet		12 x 28 / 124	
	1014	Hexagon bolt	FB = 120	M 12 x 160	
	1015	Lock nut (1x)		VM 12 / 980-8	
		Hexagon nut (2x)		M 12 / 934-8	
	1016	Tube	FB = 120	Ø 14 / 18 x 124	upon request

5 Axle clampings

5.1 General

Axle – leaf spring connection

The axle is connected to the leaf spring using the axle connection comprising: spring U-bolts, spring housing, spring pads, etc..

The (rubber) plate inserted in the spring housing prevents vibration and helps to cushion shocks.

A pin on the top spring pad projects into the two lower drilled spring layers and ensures a secure axle connection.

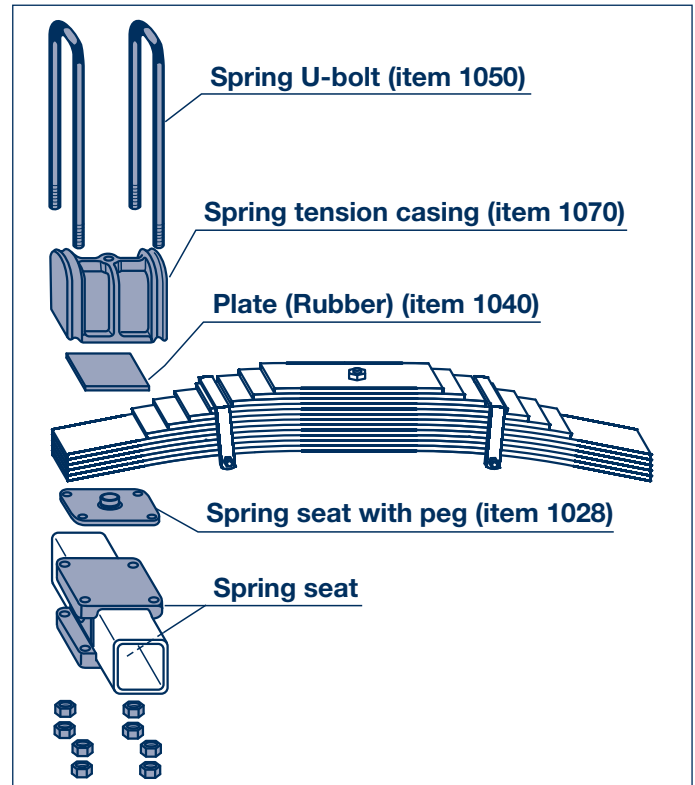

Axle alignment

After repairs have been carried out on the axle beam, trunnion axle, etc., the axle alignment must be checked and if necessary corrected.

Determine the diagonal dimensions **A - B** and **A - C** for the centre axle (reference axle) by means of comparative measurements (± 2 mm tolerance).

Check and if necessary correct the wheel base dimensions **B - D** and **C - E** for the rear axle (max. tolerance ± 2 mm).

In case of deviations, the parallel arrangement of the axles must be achieved by aligning and then welding the pin plates (no. 1028) onto the upper spring pads.

Measurement is generally carried out by means of the hub cap centre point (see illustration) or the centring hole in the axle stub.

It can also be carried out using screwed-on graduated tubes.

Hub cap centre point in the BPW logo.

The triangle (Δ) in the BPW logo is positioned centrally if there is an ® or ECO (ECO^{Plus}) stamped below the BPW logo (since 1989/1994).

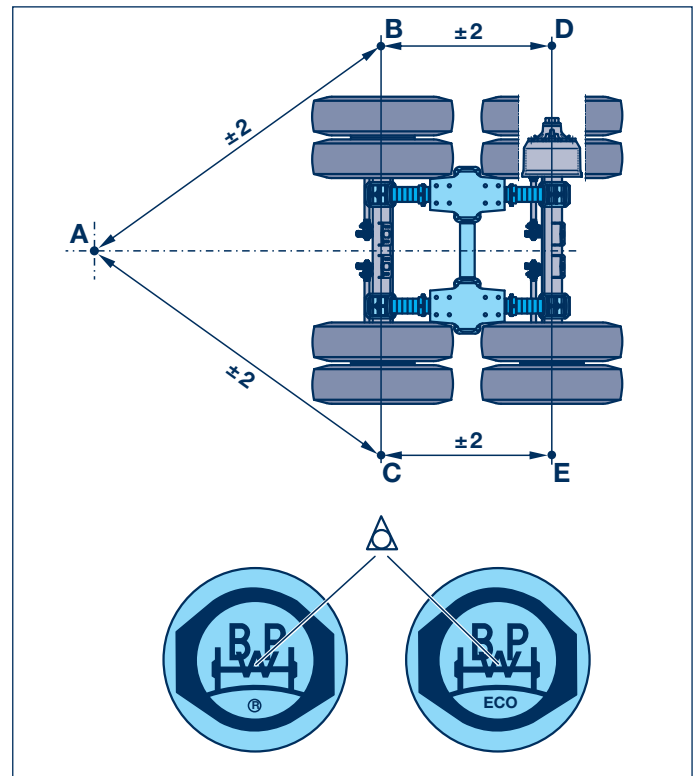

Axle clampings 5

General 5.1

Welding guidelines for axle beams

When fitting or repairing trailer axles it may be necessary to weld components onto the axle beam.

For that reason BPW axles are made of materials that can be welded. The axle beams do not have to be pre-heated before welding.

The carrying capacity and faultless operation of BPW axles are not impaired by welding, if the following points are complied with.

Welding process

- ⊙ Inert gas-shielded arc welding
Welding wire quality G 42 0 (DIN EN 440)
- ⊙ Manual arc welding
Stick electrodes E 42 2 (DIN EN 499)

Mechanical quality values must correspond to the basic material S 355 J 2 or S 420

Max. weld thickness a 5 Δ (DIN EN 25817)

Avoid end craters and undercuts.

Miscellaneous

No unauthorised change to the camber angle of the axle.
Adherence to the welding zones and weld lengths as shown in the adjacent sketch.

 **No welding must be carried out in the lower tensile zone of the axle beam!**

 **Important for all welding work!**

The leaf springs, plastic pipings and other sensitive parts should be protected against sparks and weld splashes during all welding work.

The earth terminal must under no circumstances be attached to the leaf spring or hub.

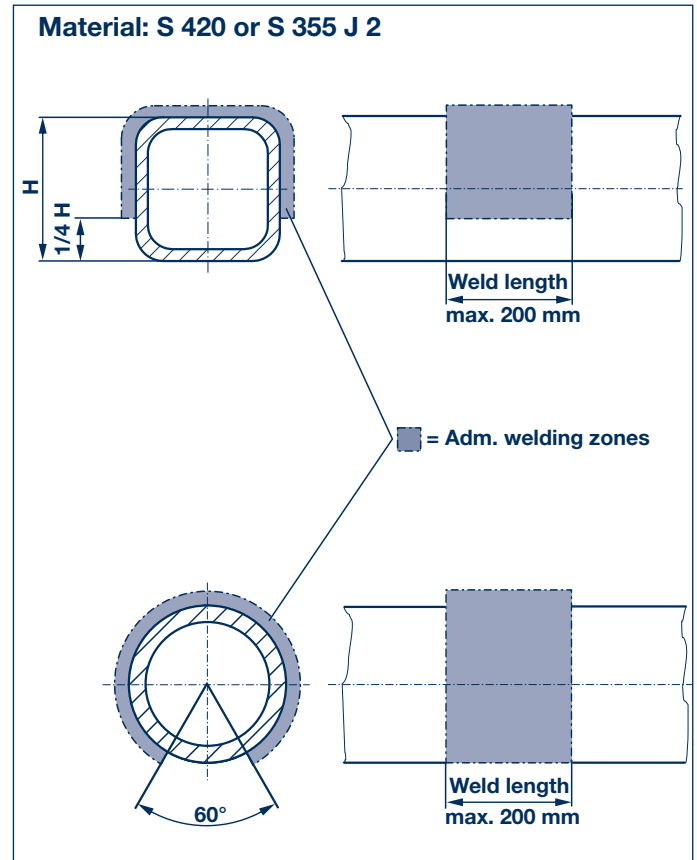

5 Axle clampings

5.2 Spring seats, axle clampings

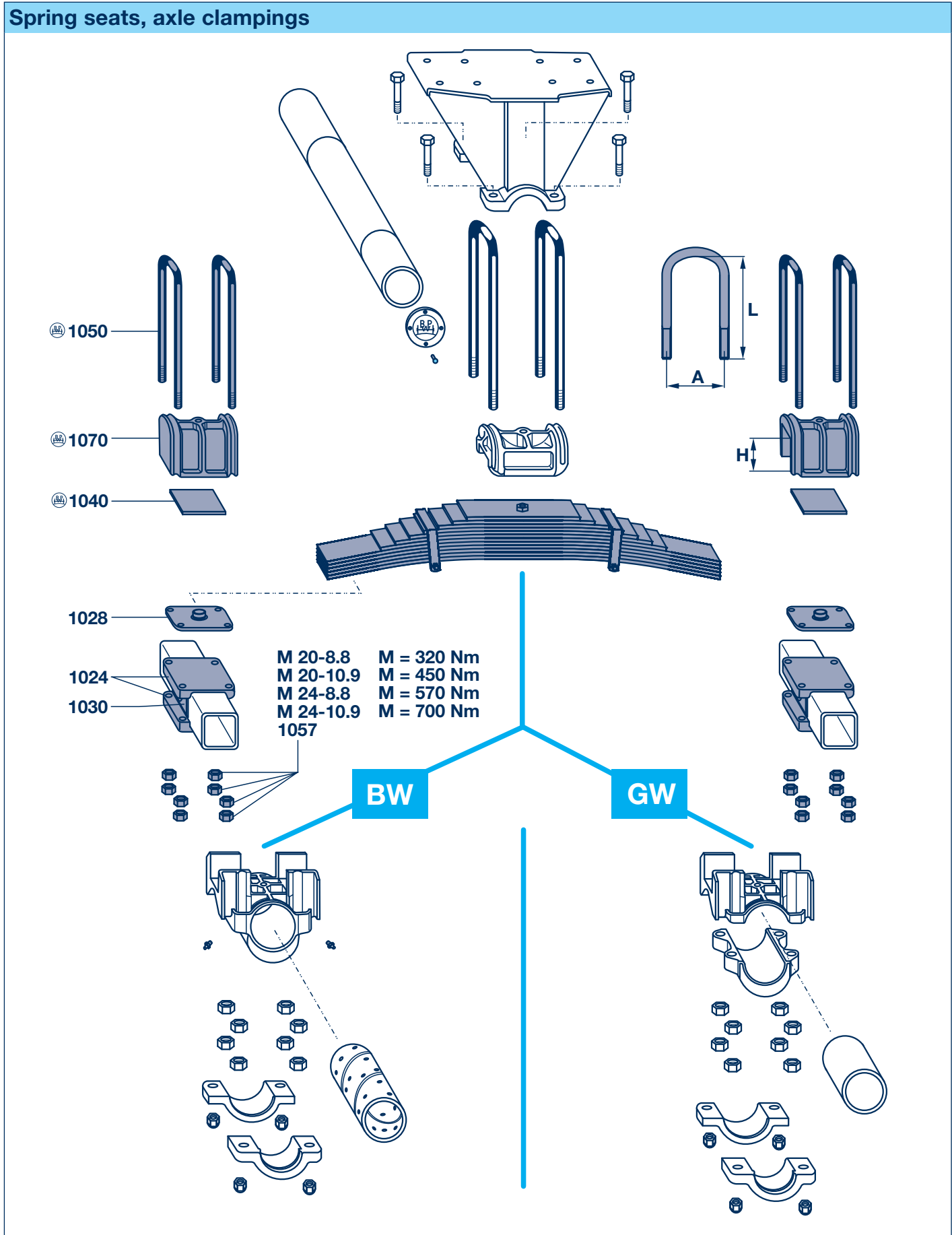

Axle clampings 5

Spring seats, axle clampings 5.2

Spring seats					
Item	Designation	BPW Code no.			
		8 - 12t Ø 127	8 - 10t □ 120	9 - 12t □ 150	13 - 20t □ 150
1024	Spring seat	03.032.38.09.0 4x	03.032.17.76.0 4x	03.032.19.22.0 4x	03.032.19.82.0 2x
1026	Spring seat	-	-	-	03.032.19.83.0 2x
1028	Spring seat with peg	03.032.17.77.0 2x	03.032.17.77.0 2x	03.032.19.27.0 2x	03.032.19.84.0 2x
1030	Shaped plate	-	03.161.64.06.0 4x	03.161.64.07.0 4x	03.161.64.07.0 4x

Axle clamping					
Item	Designation	Dimension	BPW Code no.		
			8 - 10t □ 120 / Ø 127	9 - 12t □ 150	13 - 20t □ 150
1040	Plate	115 x 130 x 16	03.289.85.01.0		
1050	Spring U-bolt	M 20 / A 160 / L 315	03.138.35.02.4	-	-
		M 20 / A 160 / L 330	03.138.35.09.4	-	-
		M 20 / A 160 / L 360	-	03.138.35.10.4	-
		M 20 / A 160 / L 380	-	03.138.35.12.4	-
		M 24 / A 192 / L 415	-	-	03.138.43.05.4 ¹⁾
1057	Hexagon nut (32x)	M 20-10.9 / 934	02.5202.24.10		-
		M 24-10.9 / 934	-		02.5202.30.10
	Lock nut (16x)	VM 20-10.9 / 980	02.5220.50.12		-
		VM 24-10.9 / 980	-		02.5220.74.12
1070	Spring tension casing	H = 81	03.146.12.03.0	03.146.12.11.0	-
		H = 95	-	03.146.12.07.0	-
		H = 107	-	-	03.146.13.01.0

* Not with leaf springs with riveted plates

¹⁾ Important! Short spring U-bolts, use only lock nuts (02.5220.74.12)

6 Trunnion axle, trunnion axle bearings

6.1 General

Trunnion axle beam

The trunnion axle consists of a thick-walled tube (or solid round stock if necessary) with two high mounting brackets bolted onto it using clamping brackets for attachment under the vehicle.

The leaf springs are enclosed by the bearing block in a U-shaped arrangement.

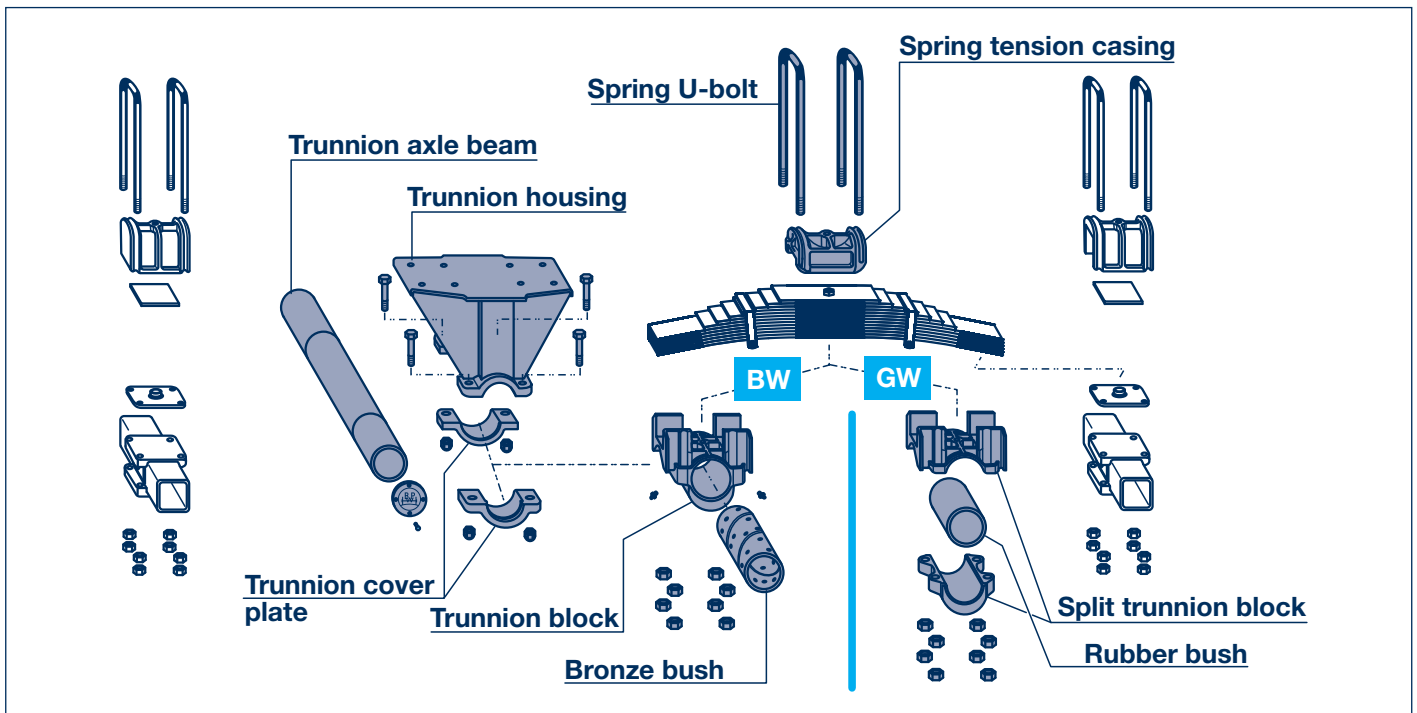
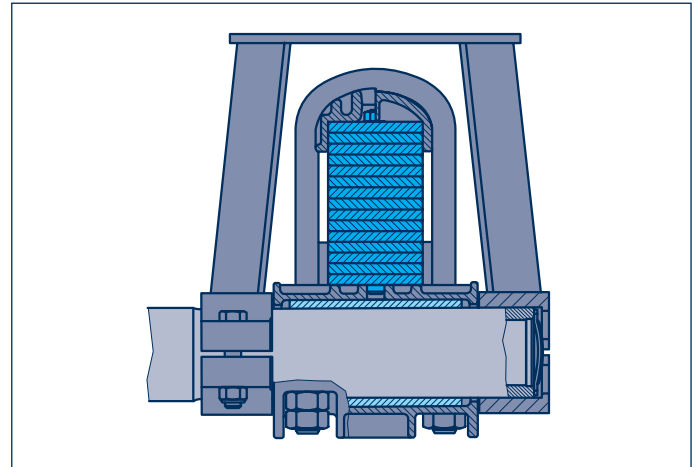

Trunnion axle – leaf spring connection

The leaf spring axle is connected to the trunnion axle beam using the trunnion axle connection comprising: spring U-bolts, spring housing, mounting brackets, etc..

The generously sized bronze bushes in the mounting brackets of **BW-units** ensure a low-maintenance, long-lasting mounting.

Grease nipples attached to the mounting brackets permit straightforward greasing of the bearing points on **BW-units**.

In **GW-units**, the bearing block is split and long-life rubber bushes permit an almost maintenance-free bearing to be achieved.

Trunnion axle, trunnion axle bearings 6

General 6.1

Trunnion axle bearing

BW

The axle support bearing consists of bronze bushes equipped with lubrication holes and ducts as well as a one-piece bearing block.

If necessary, the bronze bushes can be changed in a straightforward procedure.

GW

The axle support bearing consists of low-maintenance rubber bushes as well as a block split bearing block.

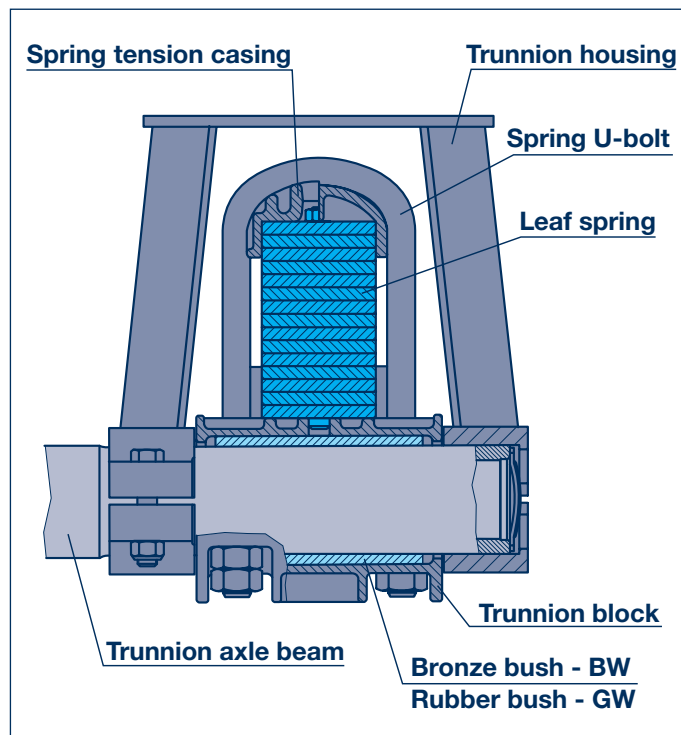

BW
GW

6 Trunnion axle, trunnion axle bearings

6.2 Trunnion axle bearing

BW
GW

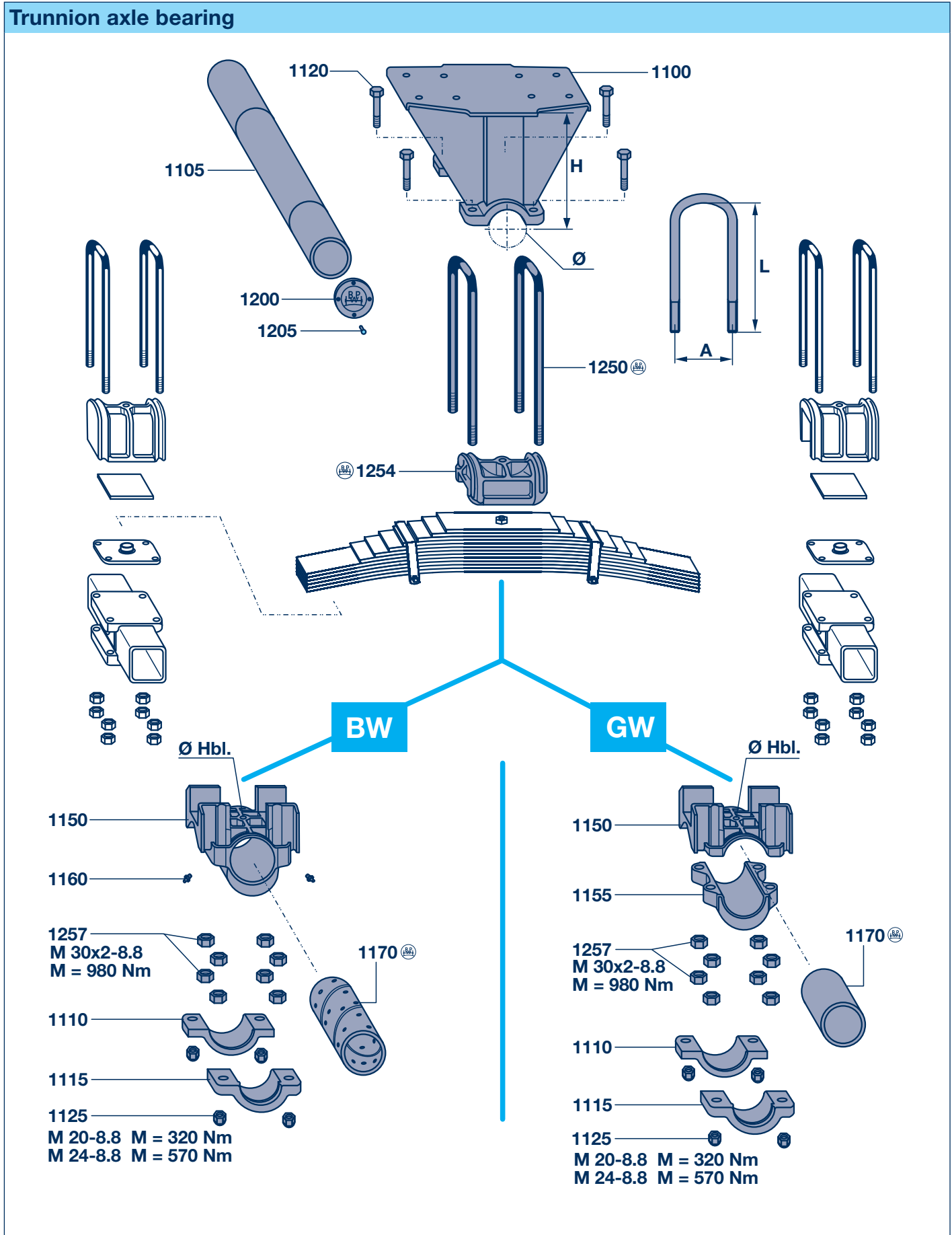

Trunnion axle, trunnion axle bearings 6

Trunnion axle bearing 6.2

Trunnion axle bearing					
Item	Designation	Dimension	BPW Code no.		
			8 - 10t □ 120 / Ø 127	9 - 12t □ 150	13 - 20t □ 150
1100	Trunnion housing	H = 370 / Ø 115	05.226.06.09.0	-	-
		H = 410 / Ø 113	-	05.226.06.07.0	-
		H = 460 / Ø 130	-	-	05.226.07.06.0
		H = 500 / Ø 130	-	-	05.226.07.05.0
1105	Trunnion axle beam		Bei Bestellung des Stützachskörpers Aggregattyp und BPW Sachnummer (Typschild) angeben.		
1110	Trunnion cover plate	Ø 115	03.227.04.14.0		-
		Ø 130	-	03.227.05.06.0	
1115	Trunnion cover plate	Ø 115	03.227.04.12.0		-
		Ø 130	-	03.227.05.05.0	
1120	Hexagon bolt	M 20 x 110 / 931-8.8	02.5023.12.80		-
		M 24 x 110 / 931-8.8	-	02.5023.46.80	
1125	Lock nut	VM 20 / 980-10	02.5220.50.12		-
		VM 24 / 980-10	-	02.5220.74.12	
GW					
1150	Trunnion housing, upper	Ø 136	03.226.06.08.0		-
1155	Trunnion housing, lower	Ø 136	03.226.06.04.0		-
1170	Bush	Ø 113 / 139 x 215	03.113.99.07.0		-
BW					
1150	Trunnion block	Ø 129 / Hbl. Ø 20	03.224.17.05.0		-
		Ø 145 / Hbl. Ø 28	-	03.224.17.06.0	
1160	Grease nipple	H 1 / S 10 x 1	02.6850.06.02		
1170	Bush	Ø 113 / 129 x 249	03.112.98.05.0		-
		Ø 130 / 145 x 249	-	03.112.99.08.0	
1200	Cover plate	Ø 109 / BPW	03.115.32.01.0		
1205	Drive pin	4 x 10 / 1476	02.6005.25.40		
1250	Spring U-bolt	M 30 x 2 / A 175 / L 390	03.138.50.06.0	-	-
		M 30 x 2 / A 175 / L 410	-	03.138.50.10.0	-
		M 30 x 2 / A 175 / L 432	-	03.138.50.08.0	-
		M 30 x 2 / A 175 / L 465	-	03.138.50.09.0	-
		M 30 x 2 / A 175 / L 505	-	-	03.138.50.11.0
		M 30 x 2 / A 175 / L 550	-	-	03.138.50.12.0
1254	Spring tension casing		03.146.14.03.0		-
			-	03.146.15.01.0	
1257	Hexagon nut	M 30 / 934-8	02.5202.38.80		

7 Lubrication and maintenance work

W
BW
GW

Lubrication and maintenance work (Overview)

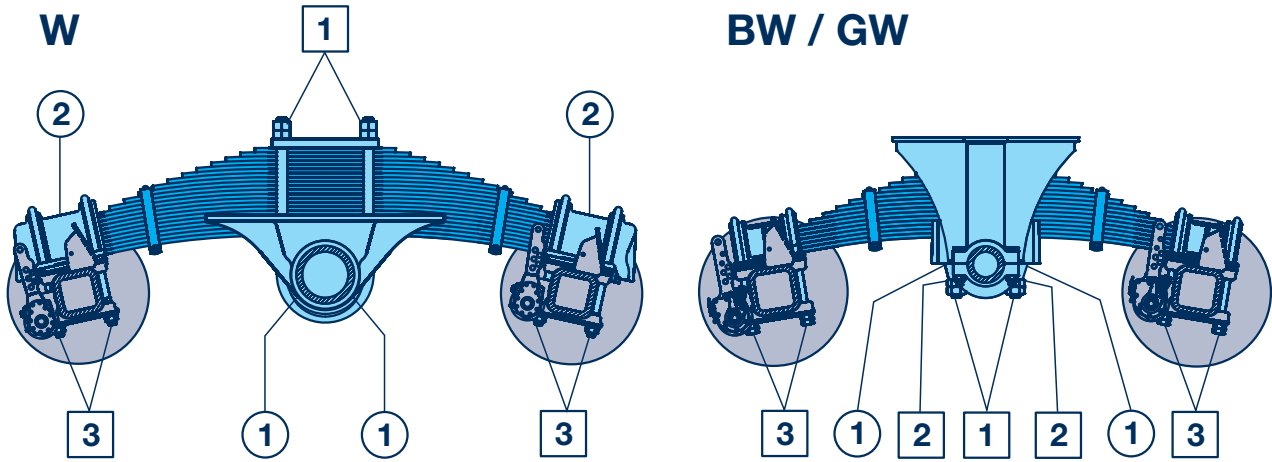

Overview		initially after 2 weeks	every 6 weeks	alle 26 Wochen (halbjährlich) ¹⁾
<input type="radio"/>	Lubricate			
<input type="checkbox"/>	Maintenance work			
①	Greasing the trunnion axle (Not required with rubber bushes). Raise the vehicle to take the weight off the bearing points.	⊙ ¹⁾	⊙ ¹⁾	
②	Grease the spring housing. (Grease for the first time when the vehicle is taken into service!)	⊙ ¹⁾	⊙ ¹⁾	
-	Visual inspection Check all parts for damage and wear.			⊙ ¹⁾
①	Use a torque wrench to check the spring U-bolts on the trunnion axle are firmly tightened. M 30 x 2-8.8 M = 980 Nm M 36-8.8 M = 1555 Nm	⊙ ¹⁾		⊙ ¹⁾
②	Check that the mounting bolts on the bearing cups are firmly tightened. M 20-8.8 M = 320 Nm M 24-8.8 M = 570 Nm			⊙ ¹⁾
③	Use a torque wrench to check the spring U-bolts on the spring housings are firmly tightened. M 20-8.8 M = 320 Nm M 20-10.9 M = 450 Nm M 24-8.8 M = 570 Nm M 24-10.9 M = 700 Nm	⊙ ¹⁾		⊙ ¹⁾

¹⁾ under extreme conditions, with more frequency.

Further information, along with installation and safety instructions, can be found in our current workshop manuals.

Notes
