

Zuggabeln

- Ⓞ Drawbars
- Ⓞ Flèches
- Ⓞ Forcelle
- Ⓞ Barras ahorquilladas de tracción

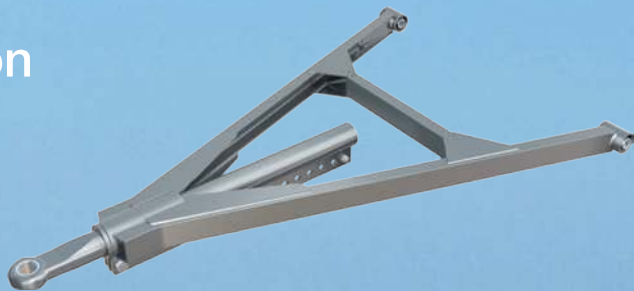

- DE** Produkte für Nutzfahrzeuge
- EN** Products for commercial vehicles
- FR** Produits pour véhicules commerciaux
- IT** Prodotti per veicoli commerciali
- ES** Gama de productos para vehículos industriales

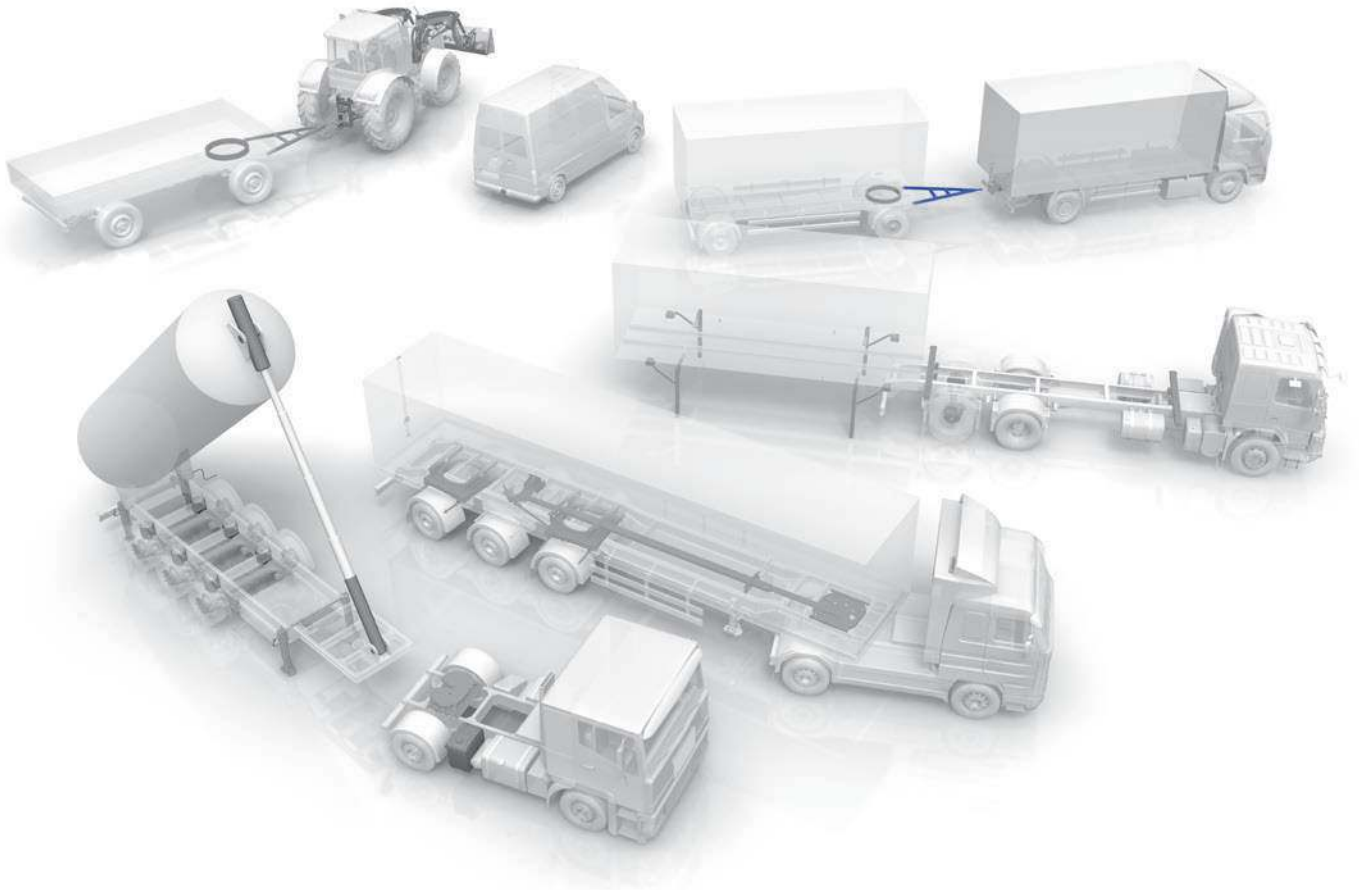

1
 Zuggabel
 Drawbar
 Flèche de remorque
 Timoni
 Lanza-timón

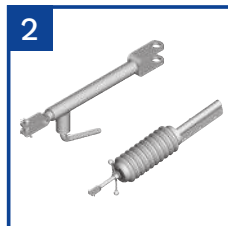

2
 Höheneinstelleinrichtung
 Height Adjustment
 System
 Dispositifs d'ajustement
 de la hauteur réglable
 Dispositivi di regolazione
 dell'altezza
 Mecanismo de regulación
 de la altura



3
 Zugstangenrohre
 Towbar pipe
 Tubes pour barre de
 traction
 Tubi barre di trazione
 Tubos de barras de
 tracción

DE Zuggabeln von ROCKINGER

JOST ist ein führender globaler Hersteller und Lieferant von sicherheitsrelevanten Systemen für die Nutzfahrzeugindustrie. Die fünf starken Marken JOST, ROCKINGER, TRIDEC, Edbro und Quicke sind für ihre intelligenten Lösungen und Produktinnovationen bekannt.

2004 hat JOST das traditionsreiche Unternehmen Regensburger Zuggabel übernommen. Das Unternehmen, das früher auch unter dem Namen Grau bekannt war, entwickelt und produziert seit fast 80 Jahren Zuggabeln. Heute werden diese Produkte unter der Marke ROCKINGER vertrieben.

EN ROCKINGER Drawbars

JOST is a leading global manufacturer and supplier of safety-relevant systems for the commercial vehicle industry. The five strong brands JOST, ROCKINGER, TRIDEC, Edbro and Quicke are well-known for their intelligent solutions and product innovations.

In 2004, JOST took over the long-established company Regensburger Zuggabel. The company, formerly known as Grau, has been developing and producing drawbars for nearly 80 years. Today on, these products are sold under the ROCKINGER brand.

FR Flèches de remorquage de ROCKINGER

JOST est le fabricant et fournisseur leader mondial de systèmes de sécurité de l'industrie des véhicules utilitaires. Les cinq marques principales : JOST, ROCKINGER, TRIDEC, Edbro et Quicke, sont connues pour leurs solutions intelligentes comme pour leurs produits innovants.

En 2004, JOST a racheté l'entreprise traditionnelle de flèches de remorquage créée à Ratisbonne. L'entreprise, connue auparavant sous le nom de Grau, développe et produit des flèches de remorquage depuis près de 80 ans. Aujourd'hui, ces produits sont distribués sous la marque ROCKINGER.

IT Barre di trazione ROCKINGER

JOST è uno dei produttori e fornitori leader al mondo di sistemi di sicurezza per l'industria dei veicoli commerciali. I cinque grandi marchi JOST, ROCKINGER, TRIDEC, Edbro e Quicke sono famosi per le loro soluzioni intelligenti e i loro prodotti innovativi.

Nel 2004, JOST ha rilevato l'azienda tradizionale Regensburger Zuggabel. L'azienda, prima nota anche con il nome Grau, sviluppa e produce barre di trazione da quasi 80 anni. Oggi, questi prodotti sono distribuiti sotto il marchio ROCKINGER.

ES Barras ahorquilladas de ROCKINGER

JOST es un fabricante y proveedor líder mundial de sistemas relacionados con la seguridad para el sector de los vehículos industriales. Sus cinco sólidas marcas JOST, ROCKINGER, TRIDEC, Edbro y Quicke son famosas por sus soluciones inteligentes y sus productos innovadores.

En 2004 JOST adquirió Regensburger Zuggabel, una empresa con una larga tradición. La empresa, también conocida anteriormente por el nombre Grau, desarrolla y produce barras ahorquilladas desde hace casi 80 años. Hoy en día, estos productos son vendidos bajo la marca ROCKINGER.

JOST-Werke, Siemensstraße 2, 63263 Neu-Isenburg
Tel.: +49 6102 295-0, Fax +49 6102 295-298
E-Mail: jost-sales@jost-world.com





JOST ROCKINGER TRIDEC Edbro Quicke



DE Inhaltsverzeichnis
EN Contents
FR Contenu
IT Contenuti
ES Contenido

Beschreibung • Description • Description • Descrizione • Descripción	Seite • Page • Page • Pagina • Página
Verwendete Piktogramme • Used pictographs • Pictogrammes utilisés • Pittogrammi utilizzati • Pictogramas empleados	6
Zugösenübersicht Bezeichnung • Overview of drawbar eyes Description • Vue de l'anneau de remorquage Désignation • Panoramica degli occhioni di traino Definizione • Vista general de las puntas de lanza Denominación	7
Hinweise und Vorschriften • Directions and Guidelines • Indications et réglementations • Norme e avvertenze • Indicaciones y especificaciones	8

		Beschreibung • Description • Description • Descrizione • Descripción	Seite • Page • Page • Pagina • Página
GNZ		Zuggabel Normalprofil • Drawbar standard profile • Flèche de remorque – profil standard • Timoni Profilo normale • Perfil normal de la lanza-timón	14
GNZ S		Zuggabel mit schräg eingeschweißter Zugöse • Drawbar with slant welded drawbar eye • Flèche de remorque avec anneaux de remorquage soudés en biais • Timoni con occhione di traino inclinato • Lanza-timón con punta de lanza soldada de forma inclinada	15
GNZ N		Zuggabel mit auswechselbarer Zugöse • Drawbar with interchangeable drawbar eye • Flèche de remorque avec anneaux deremorquage détachables • Timoni con occhione di traino intercambiabile • Lanza-timón con punta de lanza cambiabile	16
GZA		Zuggabel gekröpft • Drawbar cranked • Flèche de remorque coudée • Timone piegato a gomito • Lanza-timón acodada	17
GZL		Zuggabel längenverstellbar • Drawbar extendable • Flèche de remorque réglable en longueur • Timone regolabile in lunghezza • Lanza-timón extensible	18
GZU		Zuggabel längenverstellbar, leichte Ausführung • Drawbar extendable • Flèche de remorque réglable en longueur • Timone regolabile in lunghezza • Lanza-timón extensible	19
GZV		Zuggabel längenverstellbar • Drawbar extendable • Flèche de remorque réglable en longueur • Timone regolabile in lunghezza • Lanza-timón extensible	20
GZV BNA		Zuggabel längenverstellbar • Drawbar extendable • Flèche de remorque réglable en longueur • Timone regolabile in lunghezza • Lanza-timón extensible	21
GZLV		Zuggabel längenverstellbar, pneumatisch verriegelbar • Drawbar extendable with pneumatic lock • Flèche de remorque réglable en longueur avec verrouillage pneumatique • Timone regolabile in lunghezza con blocco pneumatico • Lanza-timón extensible con bloqueo neumático	22
GZHL		Zuggabel längenverstellbar mit gekröpfter Zugstange • Drawbar extendable, with cranked towing bar • Flèche de remorque réglable en longueur, avec barre de traction coudée • Timone regolabile in lunghezza, con barra di trazione piegata a gomito • Lanza-timón extensible, con barra de tracción acodada	24
GZHU		Zuggabel längenverstellbar, gekröpft • Drawbar extendable, cranked • Flèche de remorque réglable en longueur, coudées • Timone regolabile in lunghezza, piegate a gomito • Lanza-timón extensible, acodada	25
GZY		Zuggabel Y-Form • Drawbar Y shaped • Flèche de remorque, forme en Y • Timoni a Y • Lanza-timón en forma de Y	26
GSZ		Zuggabel mit schwenkbarer Zugöse • Drawbar with pivoting drawbar eye • Flèche de remorque anneaux de remorquage interchangeable • Occhione orientabi • Punta de lanza giratoria	29
GSG		Zuggabel mit schwenkbarer Zugöse, gekröpft • Drawbar with pivoting drawbar eye, cranked • Flèche de remorque anneaux de remorquage interchangeable, coudées • Occhione orientabi, piegate a gomito • Punta de lanza giratoria, acodada	30

GH		Höheneinstelleinrichtung, Fixierung durch Klemmung • Height Adjustment System, Fixed using clamps • Dispositifs d'ajustement de la hauteur réglable, Fixation par serrage • Dispositivi di regolazione dell'altezza, Fissaggio con bloccaggio • Mecanismo de regulación de la altura, Fijación mediante un terminal	31
GHE		Höheneinstelleinrichtung, stufenlos auf Zug einstellbar • Height Adjustment System, infinitely adjustable by pulling • Dispositifs d'ajustement de la hauteur réglable, Réglable en continu sur traction • Dispositivi di regolazione dell'altezza, Regolazione continua al traino • Mecanismo de regulación de la altura, ajuste continuo de tracción	31
GHD		Höheneinstelleinrichtung, stufenlos auf Druck einstellbar • Height Adjustment System, infinitely adjustable by pushing • Dispositifs d'ajustement de la hauteur réglable, Réglable en continu sur tension • Dispositivi di regolazione dell'altezza, Regolazione continua alla pressione • Mecanismo de regulación de la altura, ajuste continuo de presión	32
GZL / GZLG GZU / GZHU GZHL		Zugstangenrohre • Towbar pipe • Tubes pour barre de traction • Tubi barre di trazione • Tubos de barras de tracción	33

Ersatzteile und Zubehör
Spare parts and accessories
Pièces détachées et accessoires
Parti di ricambio e accessori
Piezas de recambio y accesorios

Beschreibung • Description • Description • Descrizione • Descripción	Seite • Page • Page • Pagina • Página
Zuggabelschuh • Drawbar hanger • Fixation de fleche • Supporto magnone • Soporte anclaje lanza	34
Silentlager • Silent bearings • Palier silent • Cuscinetto silent • Cojinete silent	34
Lagerbuchsen: (Messing) • Bearing bushes: (brass) • Douilles de palier: (laiton) • Gusci di cuscinetto: (in ottone) • Casquillos de cojinete: (latón)	34
Lagerbolzen • Bearing bolt • Axe de crochet • Perno ganascia • Bulón de articulación	34
Lagerbolzen Form A: (abgesetzt) • Bearing bolt form A: (extended with different diameter) • Axe de crochet forme A: (étagé) • Perno ganascia forma A: (fissato) • Bulón de articulación forma A: (recortado)	34
Lagerbolzen Form B • Bearing bolt form B • Axe de crochet, forme B • Perno ganascia forma B • Bulón de articulación forma B	34
BRIAB Zuggabelschuh • BRIAB Drawbar hanger • BRIAB Supporto magnone • BRIAB Supporto magnone • BRIAB Soporte anclaje lanza	35
BRIAB Silentlager • BRIAB Silent bearings • BRIAB Palier silent • BRIAB Cuscinetto silent • BRIAB Cojinete silent	35
BRIAB Lagerbolzen • BRIAB Bearing bolt • BRIAB axe de crochet • BRIAB Perno ganascia • BRIAB Bulón de articulación	35
Anschweißaugen • Welding eyes • Oeillets de soudure • Occhi saldati • Succión de la soldadura	35
Zugösen 40 mm/50 mm • Towing eye 40 mm/50 mm • Anneaux de remorquage 40 mm/50 mm • Occhioni die traino 40 mm/50 mm • Punta de lanza 40 mm/50 mm	35
Übermaßbuchsen • Oversize bushes • Douilles à sur-mesure • Bussole maggiorate • Casquillos de sobremedida	36
Prüflehren (Kupplungsbolzen und Zugösen) • Wear gauge (coupling pin and towing eye) • Gabarits (axes d'accouplement et anneaux de remorquage) • Calibri di controllo (perni e occhioni di traino) • Calibres de referencia (perno de acoplamiento y puntas de lanza)	36
Montagedorn zum Ein- und Ausschlagen von Zugösenbuchsen • Mounting tool for hammering in and removing towing eye bushes • Broche de montage pour enfoncer et ressortir les douilles des anneaux de remorquage • Spina di montaggio per inserire e estrarre le bussole dell'occhione • Cuña de montaje para introducir y sacar los casquillos de las puntas de lanza	36
Einroll-Werkzeug für Zugösenbuchsen • Rolling-in device for towing eye bushes • Outil de roulage pour les douilles des anneaux de remorquage • Avvolgitore per le bussole dell'occhione • Herramienta de introducción de casquillos de puntas de lanza	36
Aufschlüsselung der Artikelnummer • Breakdown to Order No. • Séquençage de la référence • Decodifica del codice articolo • Desglose de los números de artículos	37
Bestellformular • Order form • Modèle de bon • Modulo per ordine • Formulario de pedido	42

DE Verwendete Piktogramme
EN Used pictographs
FR Pictogrammes utilisés
IT Pittogrammi utilizzati
ES Pictogramas empleados

	Typ • Type • Type • Tipo • Tipo
	U Profil • U profile • Profil U • Profilo a U • Perfil en u
	Vierkantprofil • Square profile • Profils quatre pans • Profili a quadro • Perfil cuadrado
	Einhängeauge • Securing eye • Œillet d'accrochage • Occhio d'aggancio • Ojo de enganche
n	Anzahl der Bohrungen • Number of boreholes • Nombre de forages • Numero di fori • Número de perforaciones
	Gewicht • Weight • Poids • Peso • Peso
E	Zugöse • Drawbar eye • Remorquage • Occhione • Punta de lanza
V	Verschiebeweg • Slide • Course de déplacement • Percorso di spostamento • Espacio desplazable
	zulässige Vorderachslast des Drehschemels • Permissible front load of the turning steering frame • Charge avant admise de la selle orientable • Carico anteriore autorizzato della ralla • Carga delantera permitida del pivote bastidor
	empfohlene Gesamtmasse des Anhängers • Recommended maximum weight of the trailer • Masse totale recommandée de la remorque • Massa totale consigliata del rimorchio • Carga total recomendada del remolque

DE Zugösenübersicht Bezeichnung
EN Overview of drawbar eyes Description
FR Vue de l'anneau de remorquage Désignation
IT Panoramica degli occhioni di traino Definizione
ES Vista general de las puntas de lanza Denominación

Zugösenübersicht Bezeichnung • Overview of drawbar eyes Description • Vue de l'anneau de remorquage Désignation • Panoramica degli occhioni di traino Definizione • Vista general de las puntas de lanza Denominación	
1	40 DIN 74054 A
2	50 DIN 74053 A
3	50 Schwerlast/ECE • Heavy duty/ECE • Charge/ECE • Carico eccez./ECE • Carga pesada/ECE
4	40 Schweizer Zugöse • Swiss drawbar eye • Anneau de remorquage suisse • Occhione svizzero • Punta de lanza Suiza
5	57 Skandinavien Zugöse • Scandinavian drawbar eye • Skand. anneau de remorquage • Skand. occhione • Punta de lanza Skand.
6	76 VG 74059 B
7	76 VG 74059 A*
8	40 DIN 74054 B*
9	40/50 Schwenkzugöse • Pivoting drawbar eye • Anneau de remorquage pivotant • Occhione orientabile • Punta de lanza giratoria
S	40 CH/50 Schwenkzugöse • Pivoting drawbar eye • Anneau de remorquage pivotant • Occhione orientabile • Punta de lanza giratoria
N	40/76 Schwenkzugöse • Pivoting drawbar eye • Anneau de remorquage pivotant • Occhione orientabile • Punta de lanza giratoria
A	40 DIN 11026
B	40 DIN – D 140 kN Einzelabnahme • Single approval • Achat isolé • Collaudo singolo • Compra única
C	KS*80 Zugpfanne • Coupling head • Coupelle de traction • Gancio di traino • Cabeza de acoplamiento
E	50 DIN 74053 B*
F	68 BNA

* auswechselbar M 45x3 • convertible M 45x3 • remplaçable M 45x3 • intercambiabile M 45x3 • intercambiabile M 45x3

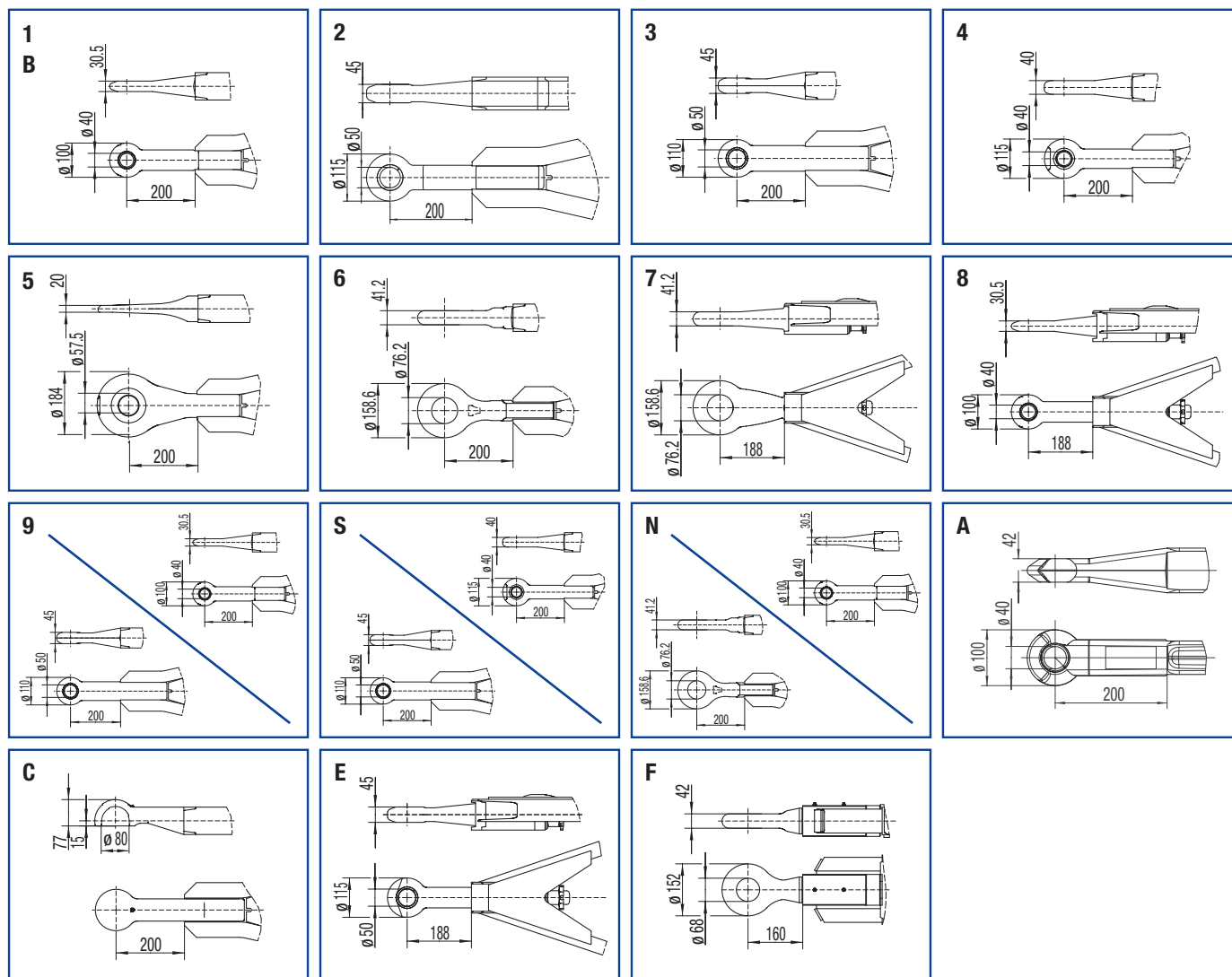

EN Directions and Guidelines

General information

Drawbars are the connection between the tractor and the steerable drawbar trailer.

They are designed to be mounted on a pivot support.

Drawbars are parts that are subject to type approval and that connect vehicles, and are therefore subject to the highest safety requirements.

They may only be operated with the compliant towing hitches and towing eyes that have been approved.

Changes of any kind (except for the ones allowed under 2.2) exclude guarantee claims and type approval is forfeited and thus the vehicle operating licence as well.

Drawbars are produced in accordance with the Directives 94/20 EC and ECE-R55 Class E. The assembly may only be completed by authorised specialist companies and according to the applicable Directives and national approval regulations. For Germany, §§ 19, 20 and 21 of the StVZO (German Road Traffic Licensing Regulations) apply. In addition, the conditions of §13 FZV relating to the duty of notification for alteration of vehicle data are to be adhered to.

1. Characteristics and range of application

The permissible load conditions for drawbars can be seen on the inscription on the factory name plate or the product overview table or the respective catalogue pages. They apply to the intended use in compliance with the Directive 94/20 EC or ECE-R55.

In the case of additional dynamic stress, e.g. operation on uneven road surfaces, construction sites and forestry, the D value should not be fully exploited or a stronger drawbar should be used i.e. enquiries should be made at ROCKINGER. Decisive for the selection of a drawbar is the D value as well as the permissible front axle load of the turning steering frame onto which it is to be attached. Specifications for the permissible maximum weight of the trailer can be used as an orientation guide and serve only as a recommendation.

The suitability of a drawbar for the combination of vehicles can be checked using the specified D value.

Truck and steerable drawbar trailer: The D value

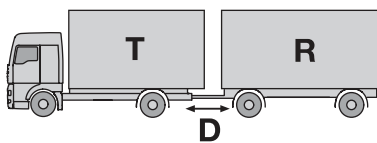

- Theoretical drawbar force between truck and trailer, calculated reference value of forces between the moving masses
- The D value can only be calculated by the permissible total weight of both measures (truck and steerable drawbar trailer)

- Calculating the D value (kN):

$$D \text{ (kN)} = g \cdot \frac{T \cdot R}{T + R}$$

T : Total weight of the truck in t

R : Total weight of the steerable drawbar trailer in t

g : acceleration due to gravity, 9.81 m/s²

The calculated D value may be the **less than** or **equal** to the D value of the drawbar.

When combining vehicles, it must be ensured that the angle (up or down) of the towing eye is not greater than 3° to the horizontal axis.

Greater deviations may lead to premature wear or even damage to the drawbar.

2. Surface treatment

Optimum protection against corrosion up to a length of 3400 mm thanks to cathodic e-coating with zinc phosphate (EPD Zn). A subsequent top coat is not necessary in normal circumstances.



Drawbars longer than 3400 mm or with widths over 1400 mm are blasted and grounded with Synthal-KH. Lasting protection against corrosion is ensured without the customer needing to add a final coat.

Hot-dip galvanizing of drawbars on request.

GNZ

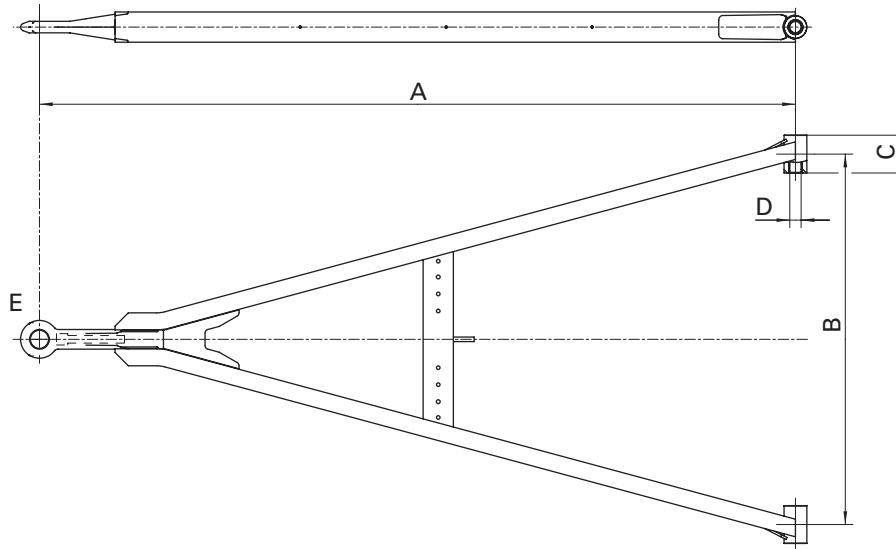
- DE** Zuggabel Normalprofil
- EN** Drawbar standard profile
- FR** Flêche de remorque – profil standard
- IT** Timoni profilo normale
- ES** Perfil normal de la lanza-timón





											
		(t)	(t)	D (kN)	EG / ECE	A (mm)	B (mm)	C (mm)	D (mm)	E	
YA	GNZ 9,4	9,4	5	70	E1 01-1964	650-750	320-1100	60-100	20-50	1,6	U 50
YA	GNZ 9,4	9,4	5	70	E1 01-1964	800-1950	320-1250	60-100	20-50	1,6	U 50
YD	GNZ 18	16	8	98	E1 01-1911	1000-2600	300-410	60-100	24-50	1,3,4,5,6,C,A	U 65
YD	GNZ 18	18	10	98	E1 01-1911	1000-1100	420-920	60-100	24-50	1,3,4,5,6,C,A	U 65
YD	GNZ 18	18	10	98	E1 01-1911	1150-1200	420-1050	60-100	24-50	1,3,4,5,6,C,A	U 65
YD	GNZ 18	18	10	98	E1 01-1911	1250-1400	420-1200	60-100	24-50	1,3,4,5,6,C,A	U 65
YD	GNZ 18	18	10	98	E1 01-1911	1450-2600	420-1400	60-100	24-50	1,3,4,5,6,C,A	U 65
YG	GNZ 27	27	12	125	E1 01-1909	1000-2050	320-1400	60-100	24-50	1,3,4,5,6,C,F	U 80
YG	GNZ 27	27	12	125	E1 01-1909	2100-3100	320-1500	60-100	24-50	1,3,4,5,6,C,F	U 80
YF	GNZ 40 A	40	12	125	E1 01-2001	1000-3800	320-590	70-100	26-50	1,6,C	U 100
YF	GNZ 40 A	40	12	125	E1 01-2001	3350-3800	320-590	70-100	26-50	3,4,5	U 100
YF	GNZ 40 A	40	18	125	E1 01-2001	1000-3800	600-1500	70-100	26-50	1,6,C	U 100
YF	GNZ 40 A	40	18	125	E1 01-2001	3350-3800	600-1500	70-100	26-50	3,4,5	U 100
YF	GNZ 40 B	40	12	168	E1 01-2021	1000-3300	320-590	70-100	30-50	3,4,5	U 100
YF	GNZ 40 B	40	18	168	E1 01-2021	1000-3300	600-1400	70-100	30-50	3,4,5	U 100
YC	GNZ 50	50	18	190	E1 01-2022	1200-3800	400-590	70-100	30-50	3,5	U 100
YC	GNZ 50	50	24	190	E1 01-2022	1200-3800	600-1400	70-100	30-50	3,5	U 100
YB	GNZ 50 HD	60	24	206	E1 01-2676	1600-3400	900-1400	70-100	30-50	3,5	U 100

GNZ S

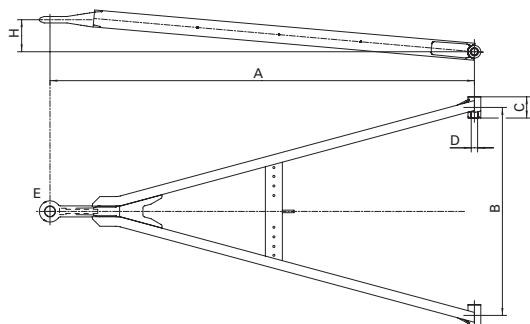
- DE** Zuggabel mit schräg eingeschweißter Zugöse
EN Drawbar with slant welded drawbar eye
FR Flèche de remorque avec anneaux de remorquage oudés en biais
IT Timoni con occhione di traino inclinato
ES Lanza-timón con punta de lanza soldada de forma inclinada







												
		(t)	(t)	D (kN)	EG / ECE	A (mm)	B (mm)	C (mm)	D (mm)	E	H max. (mm)	
YG	GNZ 27 S	27	12	125	E1 01-1909	1300-1650	320-1400	60-100	24-50	1,3,4,5,6,C	150	U 80
YG	GNZ 27 S	27	12	125	E1 01-1909	1700-2050	320-1400	60-100	24-50	1,3,4,5,6,C	200	U 80
YG	GNZ 27 S	27	12	125	E1 01-1909	2100-3100	320-1500	60-100	24-50	1,3,4,5,6,C	250	U 80
YF	GNZ 40 AS	40	12	125	E1 01-2001	1000-1150	320-590	70-100	26-50	1,3,4,5,6,C	150	U 100
YF	GNZ 40 AS	40	12	125	E1 01-2001	1200-1450	320-590	70-100	26-50	1,3,4,5,6,C	200	U 100
YF	GNZ 40 AS	40	12	125	E1 01-2001	1500-1750	320-590	70-100	26-50	1,3,4,5,6,C	250	U 100
YF	GNZ 40 AS	40	12	125	E1 01-2001	1800-2050	320-590	70-100	26-50	1,3,4,5,6,C	300	U 100
YF	GNZ 40 AS	40	12	125	E1 01-2001	2100-2350	320-590	70-100	26-50	1,3,4,5,6,C	350	U 100
YF	GNZ 40 AS	40	12	125	E1 01-2001	2400-3800	320-590	70-100	26-50	1,3,4,5,6,C	400	U 100
YF	GNZ 40 AS	40	18	125	E1 01-2001	1000-1150	600-1500	70-100	26-50	1,3,4,5,6,C	150	U 100
YF	GNZ 40 AS	40	18	125	E1 01-2001	1200-1450	600-1500	70-100	26-50	1,3,4,5,6,C	200	U 100
YF	GNZ 40 AS	40	18	125	E1 01-2001	1500-1750	600-1500	70-100	26-50	1,3,4,5,6,C	250	U 100
YF	GNZ 40 AS	40	18	125	E1 01-2001	1800-2050	600-1500	70-100	26-50	1,3,4,5,6,C	300	U 100
YF	GNZ 40 AS	40	18	125	E1 01-2001	2100-2350	600-1500	70-100	26-50	1,3,4,5,6,C	350	U 100
YF	GNZ 40 AS	40	18	125	E1 01-2001	2400-3800	600-1500	70-100	26-50	1,3,4,5,6,C	400	U 100
YF	GNZ 40 BS	40	12	168	E1 01-2021	1000-1400	320-590	70-100	30-50	3,4,5	150	U 100
YF	GNZ 40 BS	40	12	168	E1 01-2021	1450-1750	320-590	70-100	30-50	3,4,5	200	U 100
YF	GNZ 40 BS	40	12	168	E1 01-2021	1800-2100	320-590	70-100	30-50	3,4,5	250	U 100
YF	GNZ 40 BS	40	12	168	E1 01-2021	2150-2450	320-590	70-100	30-50	3,4,5	300	U 100
YF	GNZ 40 BS	40	12	168	E1 01-2021	2500-2800	320-590	70-100	30-50	3,4,5	350	U 100
YF	GNZ 40 BS	40	12	168	E1 01-2021	2850-3300	320-590	70-100	30-50	3,4,5	400	U 100
YF	GNZ 40 BS	40	18	168	E1 01-2021	1000-1400	600-1400	70-100	30-50	3,4,5	150	U 100
YF	GNZ 40 BS	40	18	168	E1 01-2021	1450-1750	600-1400	70-100	30-50	3,4,5	200	U 100
YF	GNZ 40 BS	40	18	168	E1 01-2021	1800-2100	600-1400	70-100	30-50	3,4,5	250	U 100
YF	GNZ 40 BS	40	18	168	E1 01-2021	2150-2450	600-1400	70-100	30-50	3,4,5	300	U 100
YF	GNZ 40 BS	40	18	168	E1 01-2021	2500-2800	600-1400	70-100	30-50	3,4,5	350	U 100
YF	GNZ 40 BS	40	18	168	E1 01-2021	2850-3300	600-1400	70-100	30-50	3,4,5	400	U 100
YC	GNZ 50 S	40	18	190	E1 01-2022	1200-1300	400-590	70-100	30-50	3,5	150	U 100
YC	GNZ 50 S	40	18	190	E1 01-2022	1350-1650	400-590	70-100	30-50	3,5	200	U 100
YC	GNZ 50 S	40	18	190	E1 01-2022	1700-2000	400-590	70-100	30-50	3,5	250	U 100
YC	GNZ 50 S	40	18	190	E1 01-2022	2050-2300	400-590	70-100	30-50	3,5	300	U 100
YC	GNZ 50 S	40	18	190	E1 01-2022	2350-2650	400-590	70-100	30-50	3,5	350	U 100
YC	GNZ 50 S	40	18	190	E1 01-2022	2700-3800	400-590	70-100	30-50	3,5	400	U 100
YC	GNZ 50 S	50	24	190	E1 01-2022	1200-1300	600-1400	70-100	30-50	3,5	150	U 100
YC	GNZ 50 S	50	24	190	E1 01-2022	1350-1650	600-1400	70-100	30-50	3,5	200	U 100
YC	GNZ 50 S	50	24	190	E1 01-2022	1700-2000	600-1400	70-100	30-50	3,5	250	U 100
YC	GNZ 50 S	50	24	190	E1 01-2022	2050-2300	600-1400	70-100	30-50	3,5	300	U 100
YC	GNZ 50 S	50	24	190	E1 01-2022	2350-2650	600-1400	70-100	30-50	3,5	350	U 100
YC	GNZ 50 S	50	24	190	E1 01-2022	2700-3800	600-1400	70-100	30-50	3,5	400	U 100

Andere Abmessungen auf Anfrage möglich. • Other dimensions available on request. • D'autres dimensions possibles sur demande. • Altre misure possibili su richiesta. • Otras dimensiones posibles a petición.

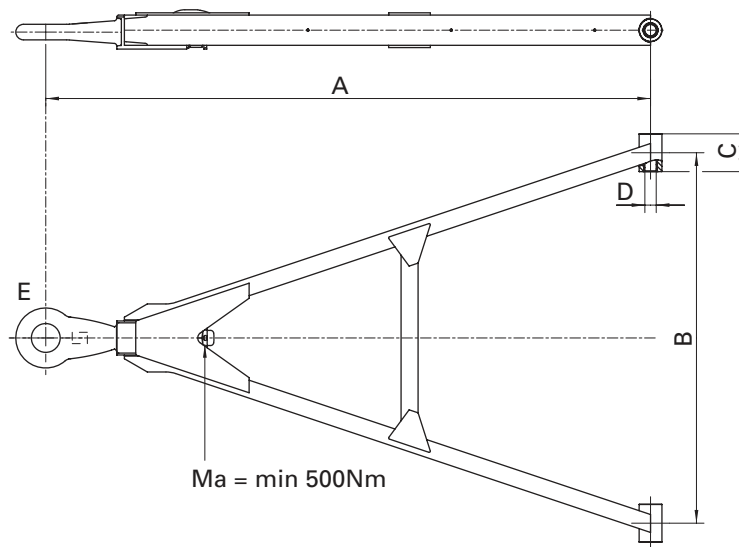
GNZ N

- DE** Zuggabel mit auswechselbarer Zugöse
- EN** Drawbar with interchangeable drawbar eye
- FR** Flêche de remorque avec anneaux deremorquage détachables
- IT** Timoni con occhione di traino intercambiabile
- ES** Lanza-timón con punta de lanza cambiabile



											
		(t)	(t)	D (kN)	EG / ECE	A (mm)	B (mm)	C (mm)	D (mm)	E	
YD	GNZ 18 N	18	10	98	E1 01-1911	1400-2600	800-1400	60-100	24-35	7,8,E	U 65
YE	GNZ 27 N	27	12	125	E1 01-1909	1000-2050	320-1400	60-100	24-50	7,8,E	U 80
YE	GNZ 27 N	27	12	125	E1 01-1909	2100-3100	320-1500	60-100	24-50	7,8,E	U 80

GZA

- DE** Zuggabel gekröpft
- EN** Drawbar cranked
- FR** Flèche de remorque coudée
- IT** Timone piegato a gomito
- ES** Lanza-timón acodada

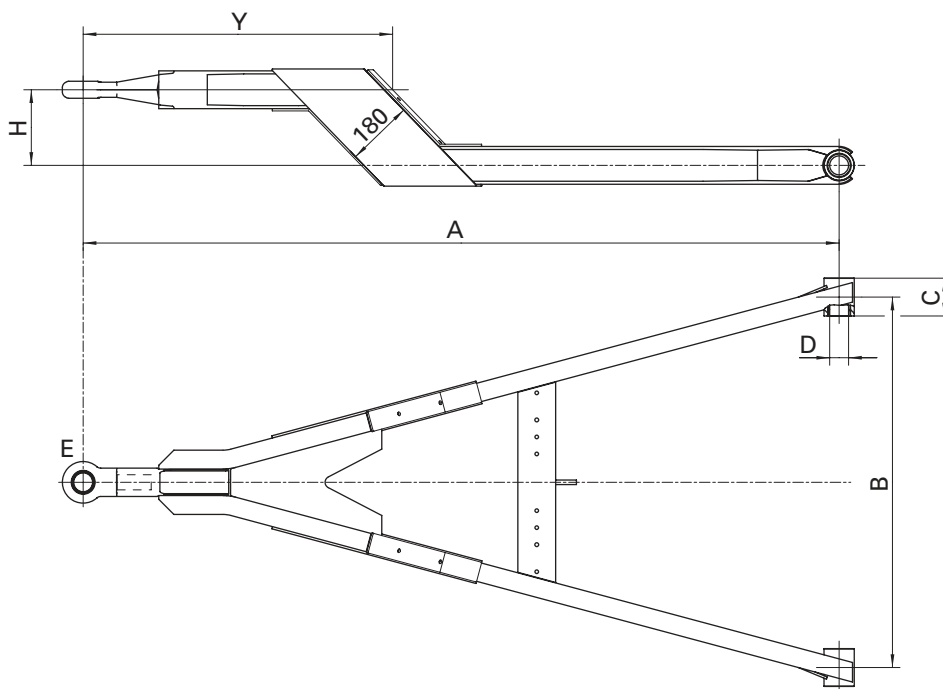

A		R		D	EG / ECE	Y	A	B	C	D	E	H max.	
		(t)	(t)	(kN)		(mm)	(mm)	(mm)	(mm)	(mm)		(mm)	
YM	GZA 40 A	40	12	125	E1-01 2516	700	950-1100	320-1400	70-100	26-50	1,3	200	U 100
YM	GZA 40 A	40	12	125	E1-01 2516	700	1150	320-1400	70-100	26-50	1,3	250	U 100
YM	GZA 40 A	40	20	125	E1-01 2516	700	1200-1250	600-1400	70-100	26-50	1,3	250	U 100
YM	GZA 40 A	40	24	125	E1-01 2516	700	1300-1350	600-1400	70-100	26-50	1,3	250	U 100
YM	GZA 40 A	40	24	125	E1-01 2516	700	1400	600-1400	70-100	26-50	1,3	300	U 100
YM	GZA 40 A	40	24	125	E1-01 2516	810	1450-1550	600-1400	70-100	26-50	1,3	300	U 100
YM	GZA 40 A	40	24	125	E1-01 2516	810	1600-2300	600-1400	70-100	26-50	1,3	350	U 100
YM	GZA 40 A	40	24	125	E1-01 2516	1010	2350-2400	600-1400	70-100	26-50	1,3	350	U 100
YM	GZA 40 A	40	24	125	E1-01 2516	1010	2450-2500	600-1400	70-100	26-50	1,3	300	U 100
YM	GZA 40 A	40	24	125	E1-01 2516	1200	2550-2800	600-1400	70-100	26-50	1,3	300	U 100

Zugösen 4, 5, 6, 7, 8, E, F, D auf Anfrage möglich. • Drawbar eye 4, 5, 6, 7, 8, E, F, D available on request. • Anneau de remorquage 4, 5, 6, 7, 8, E, F, D possibles sur demande. • Occhione di traino 4, 5, 6, 7, 8, E, F, D possibili su richiesta. • Punta de lanza 4, 5, 6, 7, 8, E, F, D posibles a petición.









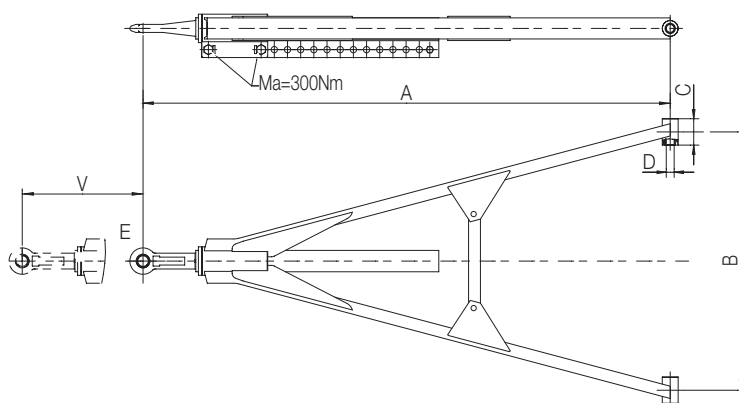



YM	GZA 40 B	40	12	160	E1-01 2528	700	1100-1150	320-1400	70-100	26-50	3,5	200	U 100
YM	GZA 40 B	40	24	160	E1-01 2528	700	1200-1350	600-1400	70-100	26-50	3,5	200	U 100
YM	GZA 40 B	40	24	160	E1-01 2528	700	1400	600-1400	70-100	26-50	3,5	250	U 100
YM	GZA 40 B	40	24	160	E1-01 2528	810	1450-1700	600-1400	70-100	26-50	3,5	250	U 100
YM	GZA 40 B	40	24	160	E1-01 2528	910	1750-1900	600-1400	70-100	26-50	3,5	250	U 100
YM	GZA 40 B	40	24	160	E1-01 2528	1010	1950-2000	600-1400	70-100	26-50	3,5	250	U 100
YM	GZA 40 B	40	24	160	E1-01 2528	1010	2050-2300	600-1400	70-100	26-50	3,5	200	U 100
YM	GZA 40 B	40	24	160	E1-01 2528	1300	2350-2800	600-1400	70-100	26-50	3,5	200	U 100

Zugösen 4, E, F auf Anfrage möglich. • Drawbar eye 4, E, F available on request. • Anneau de remorquage 4, E, F possibles sur demande. • Occhione di traino 4, E, F possibili su richiesta. • Punta de lanza 4, E, F posibles a petición.

GZL

- DE** Zuggabel l ngenverstellbar
EN Drawbar extendable
FR Fl che de remorque r glable en longueur
IT Timone regolabile in lunghezza
ES Lanza-tim n extensible



													
		(t)	(t)	(t)	(kN)		(mm)	(mm)	(mm)	(mm)		(mm)	
YS	GZL 27	27	10	10	125	E1 01-2471	1000-1150	320-1400	60-100	24-50	1,3,4,5,6,F	12x50* (16x50**)	U 80
YS	GZL 27	27	10	10	125	E1 01-2471	1200-1950	320-1400	60-100	24-50	1,3,4,5,6,F	12x50 (16x50**)	U 80
YS	GZL 27	27	12	12	125	E1 01-2471	2000-2600	320-1400	60-100	24-50	1,3,4,5,6,F	12x50 (16x50)	U 80

YT	GZL 50 A	36	10	10	125	E1-01 2604	1200-1450	300-1300	70-100	26-50	1,4,6	16x50**	U100
YT	GZL 50 A	36	12	12	125	E1-01 2604	1200-1450	300-1300	70-100	26-50	1,4,6,F	12x50	U100
YT	GZL 50 A	36	12	12	125	E1-01 2604	1500-1850	300-1300	70-100	26-50	1,4,6,F	12x50 (16x50)	U100
YT	GZL 50 A	36	12	12	125	E1-01 2604	1200-1850	300-1300	70-100	26-50	3,5	12x50 (16x50**)	U100
YT	GZL 50 A	36	12	12	125	E1-01 2604	1900-3500	300-1400	70-100	26-50	1,3,4,5,6,F	12x50 (16x50)	U100

YT	GZL 50 B	50	22	22	190	E1 55R-01 2892	1000-1150	700-1400	70-100	26-50	2,3,5	6x50	U 100
YT	GZL 50 B	50	24	24	190	E1 55R-01 2892	1200-3500	700-1400	70-100	26-50	2,3,5	6x50	U 100
YT	GZL 50 B	50	18	18	190	E1 55R-01 2892	1000-1050	700-1400	70-100	26-50	2,3,5	8x50	U 100
YT	GZL 50 B	50	20	20	190	E1 55R-01 2892	1100-1300	700-1400	70-100	26-50	2,3,5	8x50	U 100
YT	GZL 50 B	50	22	22	190	E1 55R-01 2892	1350-1550	700-1400	70-100	26-50	2,3,5	8x50	U 100
YT	GZL 50 B	50	24	24	190	E1 55R-01 2892	1600-3500	700-1400	70-100	26-50	2,3,5	8x50	U 100
YT	GZL 50 B	36	16	16	190	E1 55R-01 2892	1000-3500	300-700	70-100	26-50	2,3,5	12x50*	U 100
YT	GZL 50 B	50	16	16	190	E1 55R-01 2892	1000-1300	700-1400	70-100	26-50	2,3,5	12x50*	U 100
YT	GZL 50 B	50	18	18	190	E1 55R-01 2892	1350-1600	700-1400	70-100	26-50	2,3,5	12x50	U 100
YT	GZL 50 B	50	20	20	190	E1 55R-01 2892	1650-1950	700-1400	70-100	26-50	2,3,5	12x50	U 100
YT	GZL 50 B	50	22	22	190	E1 55R-01 2892	2000-2250	700-1400	70-100	26-50	2,3,5	12x50	U 100
YT	GZL 50 B	50	24	24	190	E1 55R-01 2892	2300-3500	700-1400	70-100	26-50	2,3,5	12x50	U 100
YT	GZL 50 B	50	12	12	190	E1 55R-01 2892	1000-1400	700-1400	70-100	26-50	2,3,5	16x50**	U 100
YT	GZL 50 B	50	16	16	190	E1 55R-01 2892	1450-1800	700-1400	70-100	26-50	2,3,5	16x50	U 100
YT	GZL 50 B	50	18	18	190	E1 55R-01 2892	1850-2200	700-1400	70-100	26-50	2,3,5	16x50	U 100
YT	GZL 50 B	50	20	20	190	E1 55R-01 2892	2250-2600	700-1400	70-100	26-50	2,3,5	16x50	U 100
YT	GZL 50 B	50	22	22	190	E1 55R-01 2892	2650-3000	700-1400	70-100	26-50	2,3,5	16x50	U 100
YT	GZL 50 B	50	24	24	190	E1 55R-01 2892	3050-3500	700-1400	70-100	26-50	2,3,5	16x50	U 100



* bis Grundl nge A < 1150 mm, Zugstangen berstand nach hinten ber cksichtigen • to basic length A < 1150 mm, note rear protrusion of towbar. •   la longueur de base A < 1150 mm, tenir compte de la r sistance des barres de remorquage vers l'arri re. • alla lunghezza di base A < 1150 mm, tenere conto della prominza posteriore della barra di trazione. • a la longitud b sica A < 1150 mm, tener en cuenta el saliente hacia atr s de la barra de tracci n.

** bis Grundl nge A < 1350 mm, Zugstangen berstand nach hinten ber cksichtigen • to basic length A < 1350 mm, note rear protrusion of towbar. •   la longueur de base A < 1350 mm, tenir compte de la r sistance des barres de remorquage vers l'arri re. • alla lunghezza di base A < 1350 mm, tenere conto della prominza posteriore della barra di trazione. • a la longitud b sica A < 1350 mm, tener en cuenta el saliente hacia atr s de la barra de tracci n.

GZU

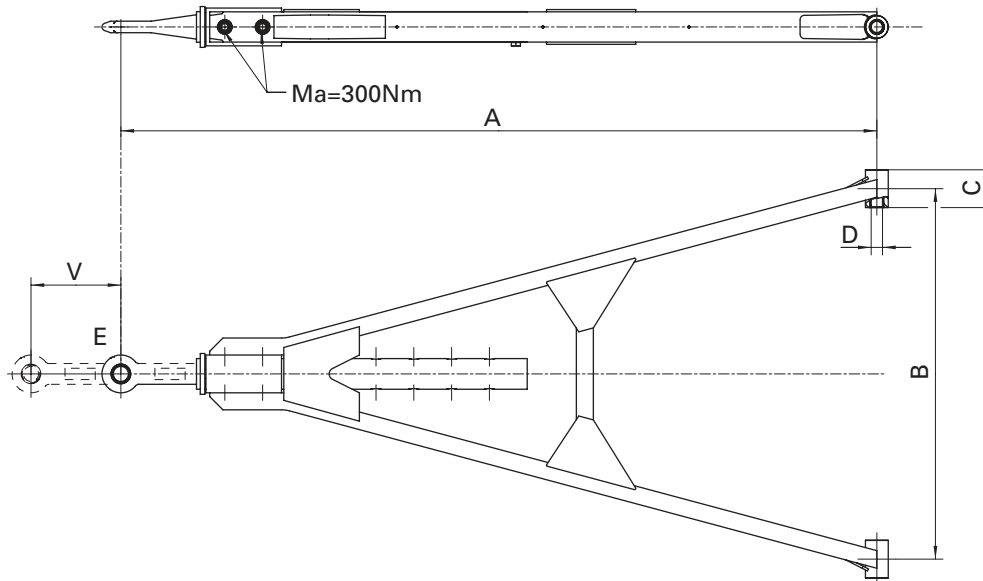
- DE** Zuggabel längenverstellbar, leichte Ausführung
- EN** Drawbar extendable, light weight design
- FR** Flèche de remorque réglable en longueur, exécution légère
- IT** Timone regolabile in lunghezza, modello leggero
- ES** Lanza-timón extensible, modelo ligero



												
		(t)	(t)	D (kN)	EG / ECE	A (mm)	B (mm)	C (mm)	D (mm)	E	V (mm)	
YH	GZU 27*	27	9	125	E1 01-2446	1200-1350	320-1400	60-100	24-50	1,3,4,5,6,	6x100	U 80
YH	GZU 27*	27	10	125	E1 01-2446	1400-1850	320-1400	60-100	24-50	1,3,4,5,6,	6x100	U 80
YH	GZU 27*	27	10	125	E1 01-2446	1900-2600	320-1400	60-100	24-50	1,3,4,5,6,	6x100 (8x100)	U 80
YJ	GZU 40 A	27	10	125	e4 00-1428	1200-1350	200-1400	70-100	26-50	1,3,4,5	5x100	U 100
YJ	GZU 40 A	27	10	125	e4 00-1428	1400-1850	200-1400	70-100	26-50	1,3,4,5	6x100	U 100
YJ	GZU 40 A	27	10	125	e4 00-1428	1900-2600	200-1400	70-100	26-50	1,3,4,5	6x100 (8x100)	U 100
YK	GZU 40 B	27	10	190	e4 00-1428	1400-1850	600-1400	70-100	26-50	3,5	6x100	U 100
YK	GZU 40 B	27	10	190	e4 00-1428	1900-2600	600-1400	70-100	26-50	3,5	6x100 (8x100)	U 100
YK	GZU 40 B	32	12	190	e4 00-1428	1650-1950	600-1400	70-100	26-50	3,5	5x100	U 100
YK	GZU 40 B	32	12	190	e4 00-1428	2000-2600	600-1400	70-100	26-50	3,5	6x100	U 100

* Nicht geeignet für Forst- u. Baustellenfahrzeuge. • Not suitable for forestry and construction vehicles. • Ne convient pas aux véhicules d'exploitation forestière ou engins de chantier • Inadatto all'impiego in cantieri e nell'economia boschiva. • No es apto para vehículos forestales y de la construcción.

GZV

- DE** Zuggabel l ngenverstellbar
- EN** Drawbar extendable
- FR** Fl che de remorque r glable en longueur
- IT** Timone regolabile in lunghezza
- ES** Lanza-tim n extensible

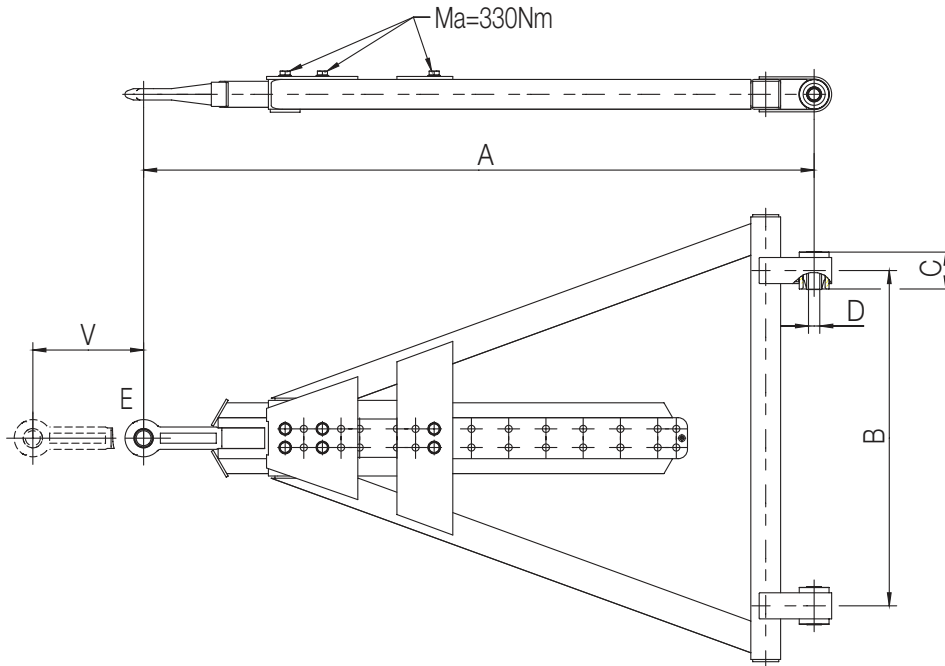

A		R		D	EG / ECE	A	B	C	D	E	V	
		(t)	(t)	(kN)		(mm)	(mm)	(mm)	(mm)		(mm)	
YW	GZV B	36	18	190	E1 01-2488	1250	800-1100	100	30-50	2,5	10x50 (500)	80 x 80
YW	GZV B	50	24	190	E1 01-2488	1500	800-1300	100	30-50	2,5	10x50 (500)	80 x 80
YW	GZV B	50	24	190	E1 01-2488	1800	800-1300	100	30-50	2,5	14x50 (700)	80 x 80
YW	GZV B	50	24	190	E1 01-2488	2300	800-1300	100	30-50	2,5	20x50 (1000)	80 x 80

GZV BNA

- DE** Zuggabel längenverstellbar
- EN** Drawbar extendable
- FR** Flèche de remorque réglable en longueur
- IT** Timone regolabile in lunghezza
- ES** Lanza-timón extensible

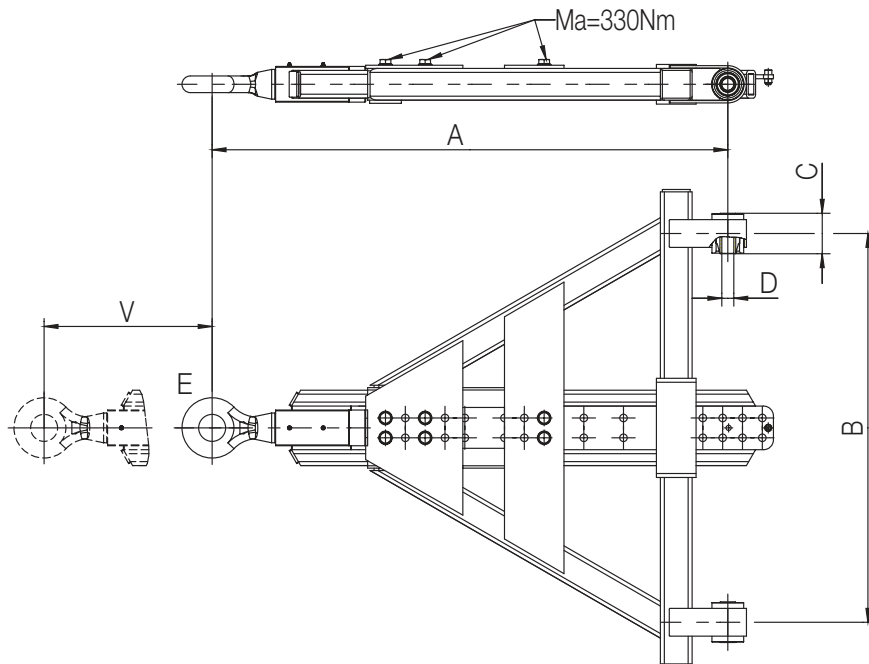
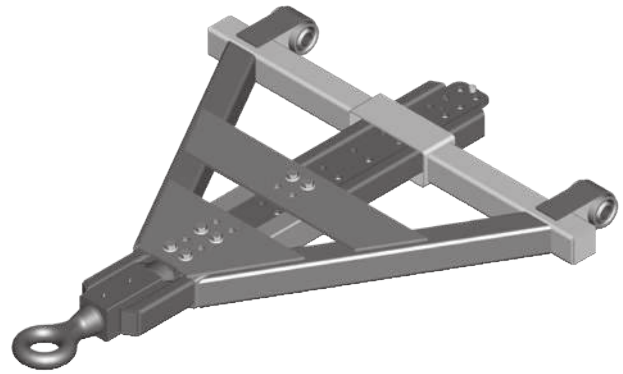



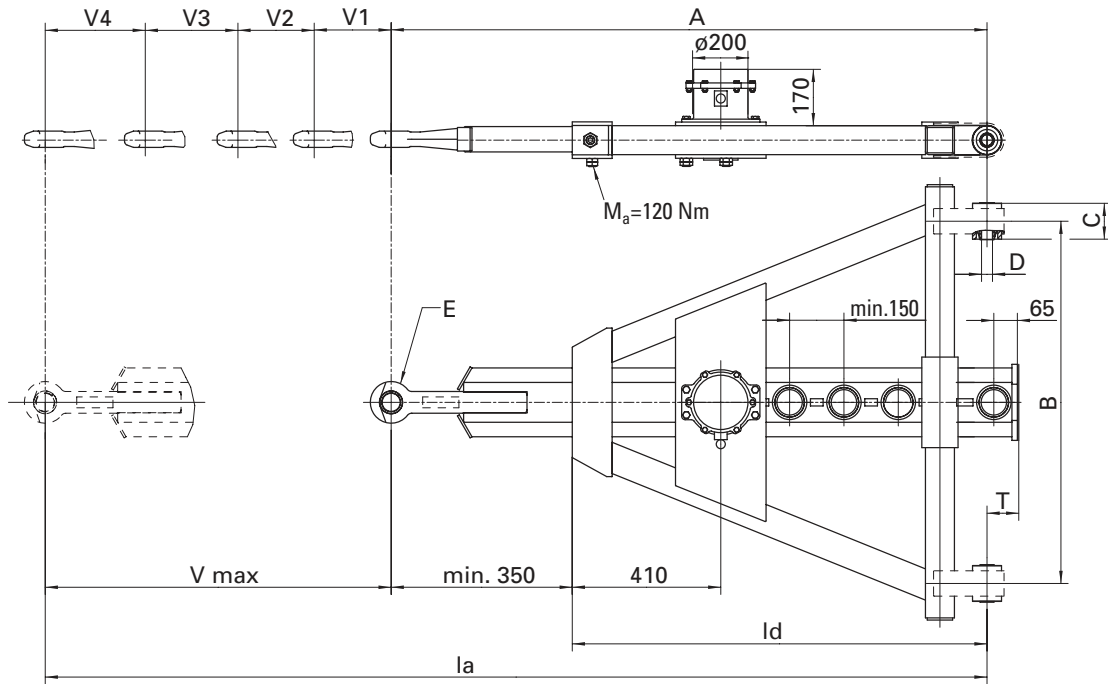
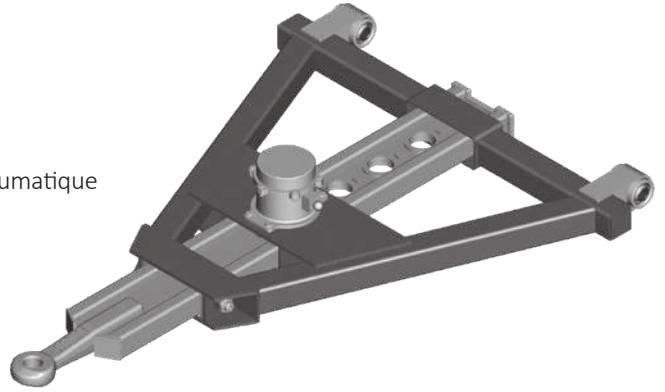

A		R		D	EG / ECE	A	B	C	D	E	V	
		(t)	(t)	(kN)		(mm)	(mm)	(mm)	(mm)		(mm)	(mm)
YW	GZV B	36	18	190	E1 01-2488	1300	800-1100	100	30-50	F (BNA)	10x50 (500)	80 x 80
YW	GZV B	50	24	190	E1 01-2488	1550	800-1300	100	30-50	F (BNA)	10x50 (500)	80 x 80
YW	GZV B	50	24	190	E1 01-2488	1850	800-1300	100	30-50	F (BNA)	14x50 (700)	80 x 80
YW	GZV B	50	24	190	E1 01-2488	2350	800-1300	100	30-50	F (BNA)	20x50 (1000)	80 x 80

GZLV

- DE** Zuggabel längenverstellbar, pneumatisch verriegelbar
- EN** Drawbar extendable with pneumatic lock
- FR** Flêche de remorque réglable en longueur avec verrouillage pneumatique
- IT** Timone regolabile in lunghezza con blocco pneumatico
- ES** Lanza-timón extensible con bloqueo neumático



													
		(t)	(t)	D (kN)	EG / ECE	A (mm)	B (mm)	C (mm)	D (mm)	E	V (mm)	(kg)	
YV	GZLV A1	50	*	125	E1 55R-01 2937	1300-2350	800-1300	100	30-50	1,4	*	140-175	80 x 80
YV	GZLV A2	50	*	125	E1 55R-01 2937	1300-2350	800-1300	100	30-50	1,4	*	140-175	80 x 80
YV	GZLV B1	50	*	190	E1 55R-01 2924	1300-2350	800-1300	100	30-50	2,5	*	140-175	80 x 80
YV	GZLV B2	50	*	190	E1 55R-01 2924	1300-2350	800-1300	100	30-50	2,5	*	140-175	80 x 80

* siehe nachfolgende Tabelle • see following table • voir le tableau suivant • vedi la seguente tabella • ver tabla siguiente

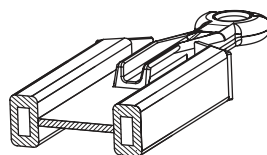
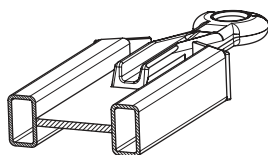

GZLV A1 + GZLV B1			la max. (mm)			
ld (mm)	A (mm) min. (t)	Av	12 t	18 t	20 t	24 t
950	1150		2850	1850	1750	–
1150	1500		3050	2150	1950	–
1450	1800		3350	2650	2450	–
1700	2050		3600	3000	2800	2500
2000	2350		3900	3500	3200	2900

GZLV A2 + GZLV B2			la max. (mm)			
ld (mm)	A (mm) min. (t)	Av	16 t	18 t	20 t	24 t
950	1150		3300	2850	2450	–/2050**
1150	1500		3500	3250	2850	–/2350**
1450	1800		–	3800	3350	2850
1700	2050		–	4050	3800	3200
2000	2350		–	–	4350	3700

** nur Ausführung GZLV B2 • only version GZLV B2 • seule version GZLV B2 • solo versione GZLV B2 • única versión GZLV B2

DE max. 4 Verstellungen – verdrehte Montage um 180° zulässig – Abstände der Verstellung bei Bestellung frei wählbar (Mindestabstand untereinander 150mm) – Spiel der Zugstange einstellbar – pneum. Ansteuerung nicht im Lieferumfang – pneum. Zylinder, federbelastet, max. 8bar, einfach- oder doppelwirkend anschließbar – Bei großem Verstellweg unbedingt Maß T beachten ($T = V_{max} + 410 + 65 - ld$)

EN max. 4 adjustments – assembly twisted by 180° permitted – spacing of adjustments can be freely selected when ordering (minimum vertical clearance of 150mm) – play of towbar adjustable – pneum. activation not included – pneum. cylinder, spring loaded, max. 8 bar, can be connected for single or double-action – dimension T must be noted for large adjustments ($T = V_{max} + 410 + 65 - ld$)

FR Max. 4 réglages – Montage vrillé à 180° autorisé – Distance des réglages lors de la commande sélectionnable librement (distance minimale entre chaque: 150 mm) – Jeu de la barre de remorquage réglable – Pilotage pneumatique non compris dans le contenu de livraison – Cylindre pneumatique, commandé par ressort, max. 8 bar, connectable à simple ou double effet – Absolument prendre en compte la valeur T lors d’une course de réglage importante ($T = V_{max} + 410 + 65 - ld$)

IT Spostamento max. 4 – È autorizzato il montaggio sfalsato di 180° – Distanze di spostamento a scelta a piacere al momento dell’ordinazione (distanza reciproca minima 150mm) – Gioco impostabile della barra di trazione – Comando pneumatico non compreso nella fornitura – Cilindri pneumatici caricati a molla, max. 8bar, collegabili a effetto singolo o doppio – Se il percorso di spostamento è elevato, rispettare assolutamente la misura T ($T = V_{max} + 410 + 65 - ld$)

ES máx. 4 ajustes – posibilidad de montaje girado hasta 180° – libre selección de la distancia de ajuste en el pedido (distancia mínima de 150mm) – juego de la barra de tracción ajustable – control neum. no incluido en el suministro – cilindro neum., cargado por resorte, máx. 8 bar, con posibilidad de conexión con efecto simple o doble – si el desplazamiento de ajuste es grande, tenga en cuenta la medida T ($T = V_{max} + 410 + 65 - ld$)

- DE** Ersatzteile
- EN** Spare parts
- FR** Pièces détachées
- IT** Parti di ricambio
- ES** Piezas de recambio

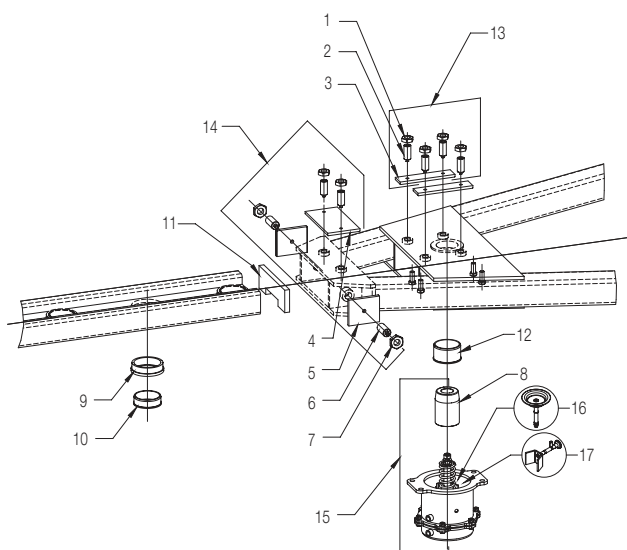



Pos.	
1	Y053012909
2	Y016385309
3	Y015188309
4	Y015188809
5	Y015188909
6	Y016385409
7	Y053013009
8	Y255000060
9	Y016385509
10	Y016385609
11	Y015189419
12	Y016385209
13	Y255000040
14	Y255000030
15	Y002005309
16	Y255000050
17	Y255000070

GZHL

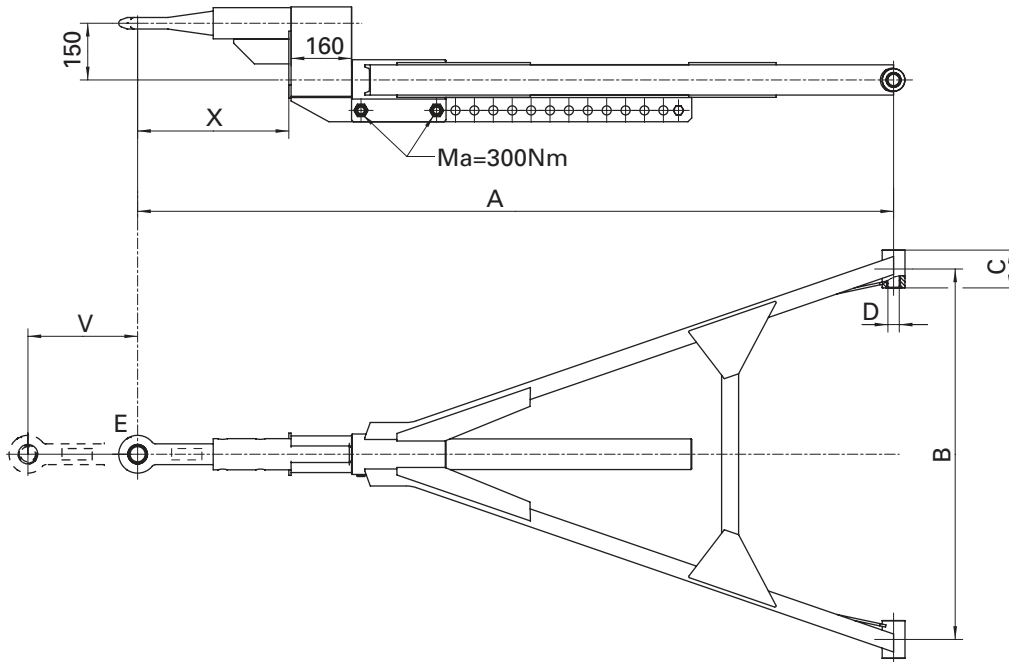
- DE** Zuggabel längenverstellbar mit gekröpfter Zugstange
- EN** Drawbar extendable, with cranked towing bar
- FR** Flêche de remorque réglable en longueur, avec barre de traction coude
- IT** Timone regolabile in lunghezza, con barra di trazione piegata a gomito
- ES** Lanza-timón extensible, con barra de tracción acodada



				D	EG / ECE	A	B	C	D	E	V	X	
		(t)	(t)	(kN)		(mm)	(mm)	(mm)	(mm)		(mm)	(mm)	
YU	GZHL 30 A**	30	10	120	e4 00-2243	1100-1250	600-1300	60-100	24-50	1,3,4	8x50, (12x50*)	200	U 80
YU	GZHL 30 A**	30	10	120	e4 00-2243	1300-1450	600-1300	60-100	24-50	1,3,4	8x50, (12x50*)	400	U 80
YU	GZHL 30 A**	30	10	120	e4 00-2243	1500-1900	600-1300	60-100	24-50	1,3,4	12x50	400	U 80
YU	GZHL 30 B**	30	10	100	e4 00-2243	1950-2400	600-1300	60-100	24-50	1,3,4	12x50	400	U 80

* Zugstangenüberstand nach hinten berücksichtigen. • note rear protrusion of towbar • Tenir compte de la résistance des barres de remorquage vers l'arrière • Tenere conto della prominenza posteriore della barra di trazione • Tener en cuenta el saliente hacia atrás de la barra de tracción

** Nicht geeignet für Forst- u. Baustellenfahrzeuge. • Not suitable for forestry and construction vehicles. • Ne convient pas aux véhicules d'exploitation forestière ou engins de chantier • Inadatto all'impiego in cantieri e nell'economia boschiva. • No es apto para vehículos forestales y de la construcción.

GZHU

- DE** Zuggabel längenverstellbar, gekröpft
- EN** Drawbar extendable, cranked
- FR** Flèche de remorque réglable en longueur, coudées
- IT** Timone regolabile in lunghezza, piegata a gomito
- ES** Lanza-timón extensible, acodada

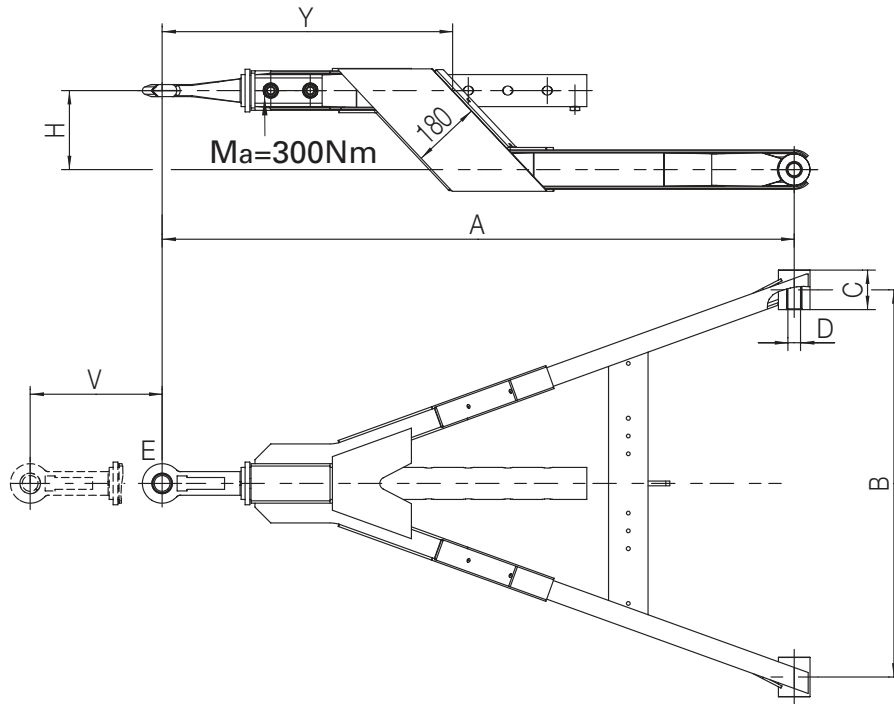







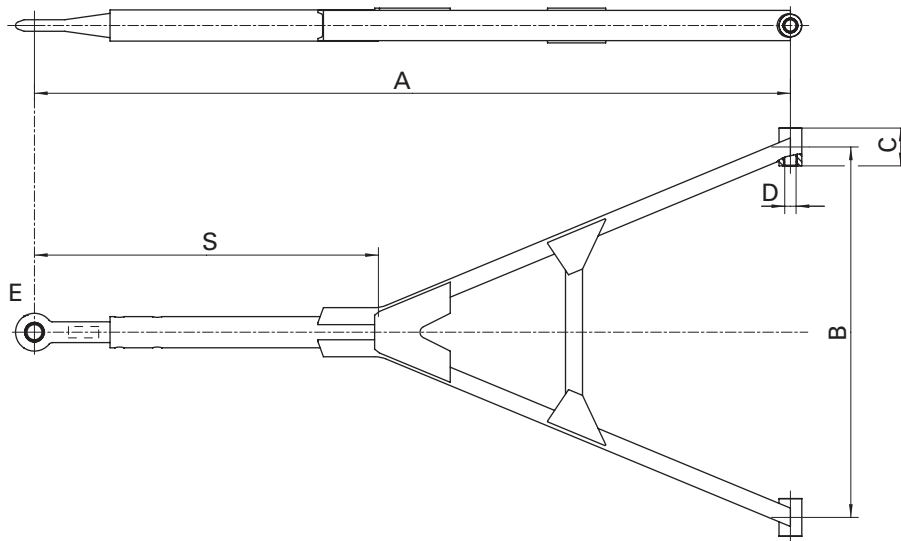
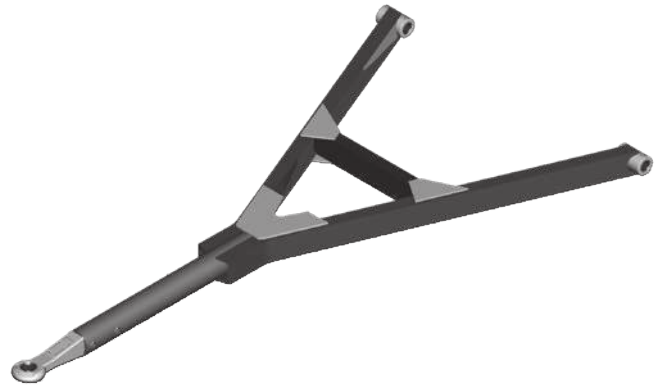





		R (t) (t)		D (kN)	EG / ECE	Y (mm)	A (mm)	B (mm)	C (mm)	D (mm)	E	H (mm)	V (mm)	
YI	GZHU 40	32	10	125	e4 00-1004	750	1200-1350	200-1400	70-100	24-50	1,3,4,5	150 (100, 200, 250)	5x100	U 100
YI	GZHU 40	32	10	125	e4 00-1004	750	1400-1850	200-1400	70-100	24-50	1,3,4,5	150 (100, 200, 250)	6x100	U 100
YI	GZHU 40	32	10	125	e4 00-1004	800	1900-2100	200-1400	70-100	24-50	1,3,4,5	150 (100, 200, 250)	6x100 (8x100)	U 100
YI	GZHU 40	32	10	125	e4 00-1004	900	2150-2600	200-1400	70-100	24-50	1,3,4,5	150 (100, 200, 250)	6x100 (8x100)	U 100

GZY 27

- DE** Zuggabel Y-Form
- EN** Drawbar Y shaped
- FR** Flêche de remorque, forme en Y
- IT** Timoni a Y
- ES** Lanza-timón en forma de Y







												
		(t)	(t)	(kN)		(mm)	(mm)	(mm)	(mm)	(mm)		
YY	GZY 27*	27	10	125	E1 01-2464	600	1300-1750	320-1400	60-100	24-50	1,3,4,5,6	U 80
YY	GZY 27*	27	10	125	E1 01-2464	900	1800-2050	320-1400	60-100	24-50	1,3,4,5,6	U 80
YY	GZY 27*	27	10	125	E1 01-2464	1100	2100-3300	320-1500	60-100	24-50	1,3,4,5,6	U 80

* Nicht geeignet für Forst- u. Baustellenfahrzeuge. • Not suitable for forestry and construction vehicles. • Ne convient pas aux véhicules d'exploitation forestière ou engins de chantier • Inadatto all'impiego in cantieri e nell'economia boschiva. • No es apto para vehículos forestales y de la construcción.

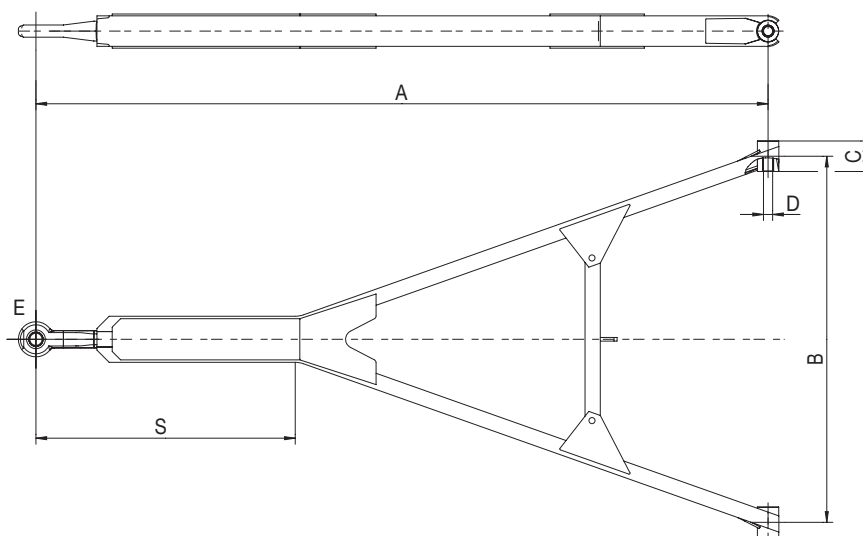



GZY 36

- DE** Zuggabel Y-Form
- EN** Drawbar Y shaped
- FR** Flêche de remorque, forme en Y
- IT** Timoni a Y
- ES** Lanza-timón en forma de Y

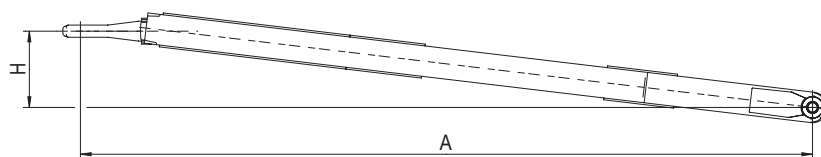

					D	EG / ECE	S	A	B	C	D	E	
			(t)	(t)	(kN)		(mm)	(mm)	(mm)	(mm)	(mm)		
YX	GZY 36		36	12	125	E1 01-2314	650	1300-1350	600-1100	70-100	24-50	1,3,4,5,6,C	U 100
YX	GZY 36		36	12	125	E1 01-2314	650	1400-1750	600-1400	70-100	24-50	1,3,4,5,6,C	U 100
YX	GZY 36		36	12	125	E1 01-2314	850	1800-2150	600-1400	70-100	24-50	1,3,4,5,6,C	U 100
YX	GZY 36		36	12	125	E1 01-2314	1100	2200-3500	600-1400	70-100	24-50	1,3,4,5,6,C	U 100





					D	EG / ECE	S	A	B	C	D	E	H max.	
			(t)	(t)	(kN)		(mm)	(mm)	(mm)	(mm)	(mm)		(mm)	
YX	GZY 36 S		36	12	125	E1 01-2314	650	1300-1350	600-1100	70-100	24-50	1,3,4,5,6,	150	U 100
YX	GZY 36 S		36	12	125	E1 01-2314	650	1400-1450	600-1400	70-100	24-50	1,3,4,5,6,	150	U 100
YX	GZY 36 S		36	12	125	E1 01-2314	650	1500-1750	600-1400	70-100	24-50	1,3,4,5,6,	150 (max. 200)	U 100
YX	GZY 36 S		36	12	125	E1 01-2314	850	1800-2050	600-1400	70-100	24-50	1,3,4,5,6,	150 (max. 250)	U 100
YX	GZY 36 S		36	12	125	E1 01-2314	1100	2100-2350	600-1400	70-100	24-50	1,3,4,5,6,	150 (max. 300)	U 100
YX	GZY 36 S		36	12	125	E1 01-2314	1100	2400-3500	600-1400	70-100	24-50	1,3,4,5,6,	150 (max. 350)	U 100

GZY 44

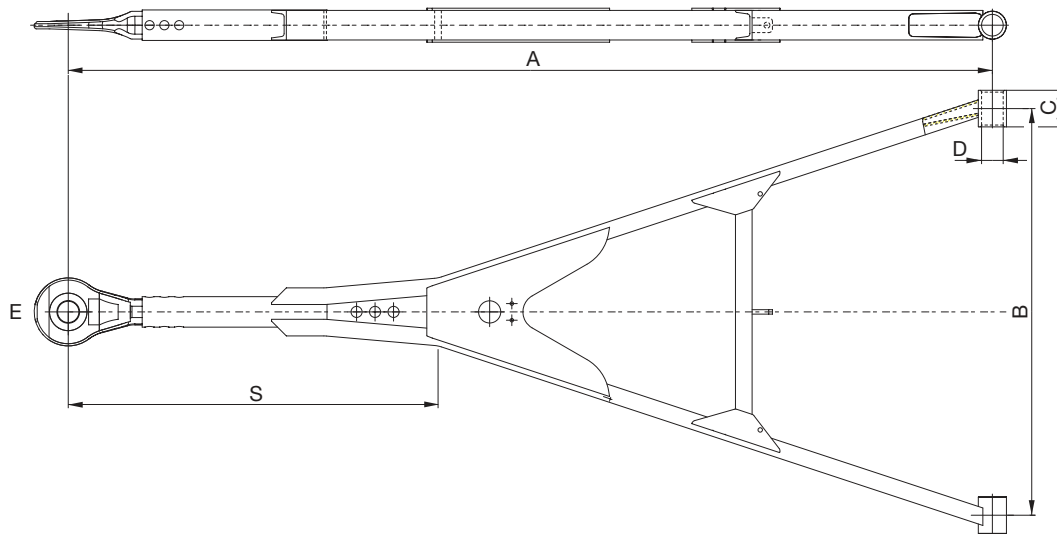
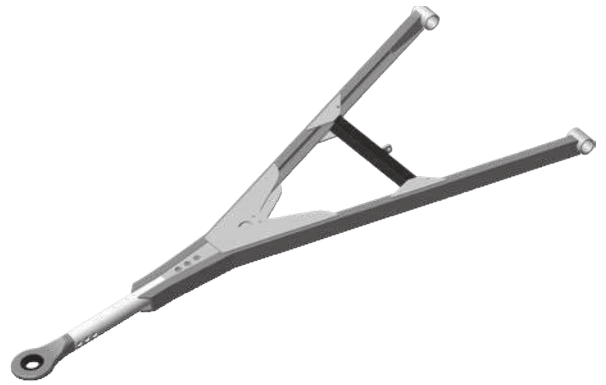
- DE** Zuggabel Y-Form
- EN** Drawbar Y shaped
- FR** Flêche de remorque, forme en Y
- IT** Timoni a Y
- ES** Lanza-timón en forma de Y





												
YZ	GZY 44	44 (t)	18 (t)	D (kN)	EG / ECE	S (mm)	A (mm)	B (mm)	C (mm)	D (mm)	E	U 80
YZ	GZY 44	44	18	190	E1 01-2831	800	2300-2450	900-1300	70-100	26-50	2, 5	U 80
YZ	GZY 44	44	18	190	E1 01-2831	1000	2500-3000	900-1300	70-100	26-50	2, 5	U 80

GSZ

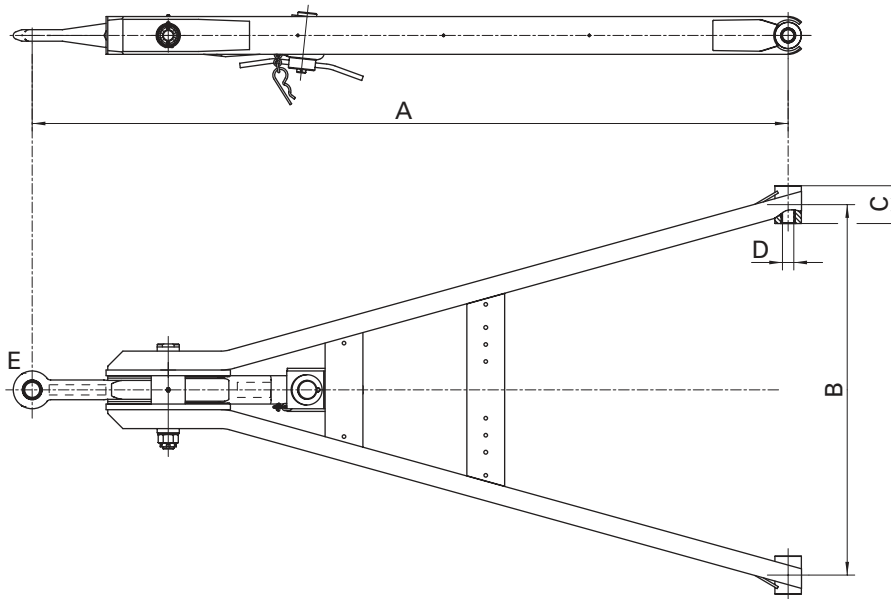
- DE** Zuggabel mit schwenkbarer Zugöse
- EN** Drawbar with pivoting drawbar eye
- FR** Flèche de remorque anneaux de remorquage interchangeable
- IT** Occhione orientabi
- ES** Punta de lanza giratoria



											
		R		D	EG / ECE	A	B	C	D	E	
		(t)	(t)	(kN)		(mm)	(mm)	(mm)	(mm)		
YO	GSZ 50 A	36	12	125	E1-01 2840	1100-3300	320-590	70-100	24-50	1/6	U 100
YO	GSZ 50 A	36	12	125	E1-01 2840	1100-1250	600-1400	70-100	24-50	1/6	U 100
YO	GSZ 50 A	50	18	125	E1-01 2840	1300-1450	600-1400	70-100	24-50	1/6	U 100
YO	GSZ 50 A	50	20	125	E1-01 2840	1500-3300	600-1400	70-100	24-50	1/6	U 100
YO	GSZ 50 B	36	12	125/190	E1-01 2865	1100-3300	320-590	70-100	24-50	1/3	U 100
YO	GSZ 50 B	50	12/24	125/190	E1-01 2865	1100-1200	600-1400	70-100	24-50	1/3	U 100
YO	GSZ 50 B	50	18/24	125/190	E1-01 2865	1250-1450	600-1400	70-100	24-50	1/3	U 100
YO	GSZ 50 B	50	20/24	125/190	E1-01 2865	1500-1950	600-1400	70-100	24-50	1/3	U 100
YO	GSZ 50 B	50	24	125/190	E1-01 2865	2000-3300	600-1400	70-100	24-50	1/3	U 100
YO	GSZ 50 B	36	12	125/190	E1-01 2865	1100-3300	320-590	70-100	24-50	4/3	U 100
YO	GSZ 50 B	50	12/24	125/190	E1-01 2865	1100-1750	600-1400	70-100	24-50	4/3	U 100
YO	GSZ 50 B	50	18/24	125/190	E1-01 2865	1800-2050	600-1400	70-100	24-50	4/3	U 100
YO	GSZ 50 B	50	20/24	125/190	E1-01 2865	2100-3300	600-1400	70-100	24-50	4/3	U 100

- DE** Ersatzteile
- EN** Spare parts
- FR** Pièces détachées
- IT** Parti di ricambio
- ES** Piezas de recambio

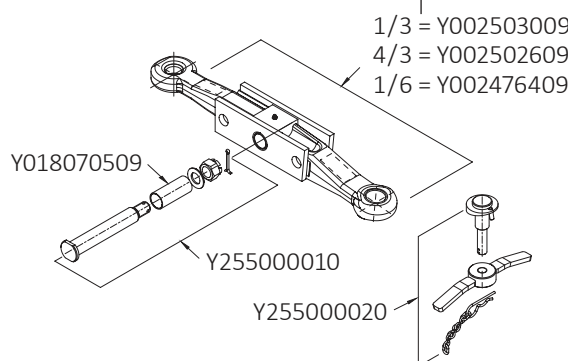

GSG

- DE** Zuggabel mit schwenkbarer Zugöse, gekröpft
- EN** Drawbar with pivoting drawbar eye, cranked
- FR** Flêche de remorque anneaux de remorquage
- IT** interchangeable, coudées
- Occhione orientabili, piegata a gomito
- ES** Punta de lanza giratoria, acodada

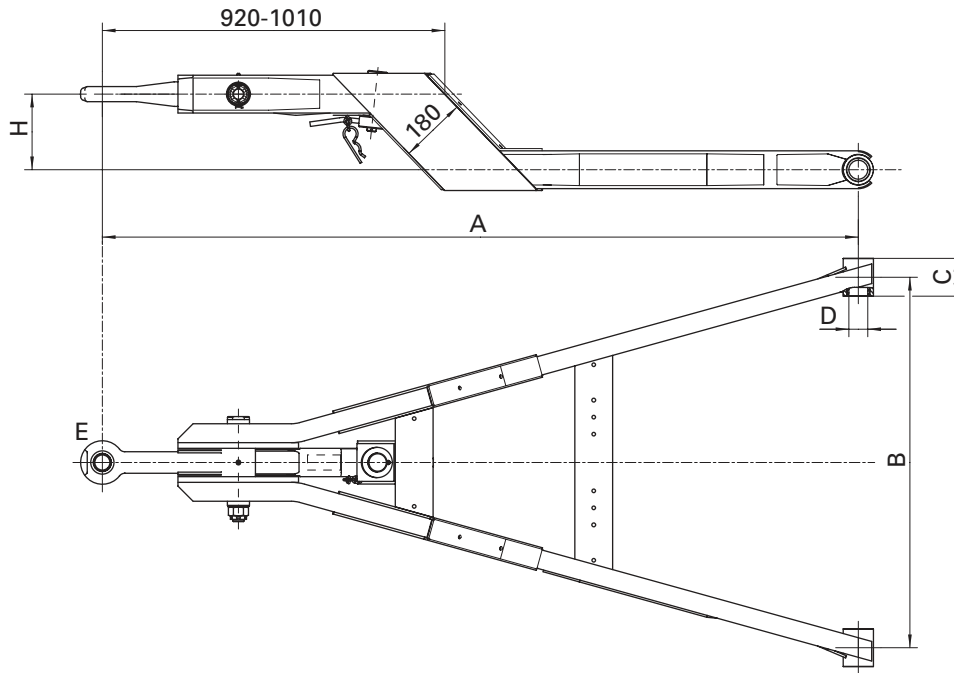

A		R		D	EG / ECE	A	B	C	D	E	H	
		(t)	(t)	(kN)		(mm)	(mm)	(mm)	(mm)		(mm)	
YN	GSG	50	24	125/160	e4 00-3287	1400-1450	400-1400	70-100	24-50	1/3 (4/3)	150 (200)	U 100
YN	GSG	50	24	125/160	e4 00-3287	1500-2000	400-1400	70-100	24-50	1/3 (4/3)	150 (200, 250)	U 100
YN	GSG	50	24	125/160	e4 00-3287	2050-2800	400-1400	70-100	24-50	1/3 (4/3)	150	U 100

- DE** Ersatzteile
- EN** Spare parts
- FR** Pièces détachées
- IT** Parti di ricambio
- ES** Piezas de recambio

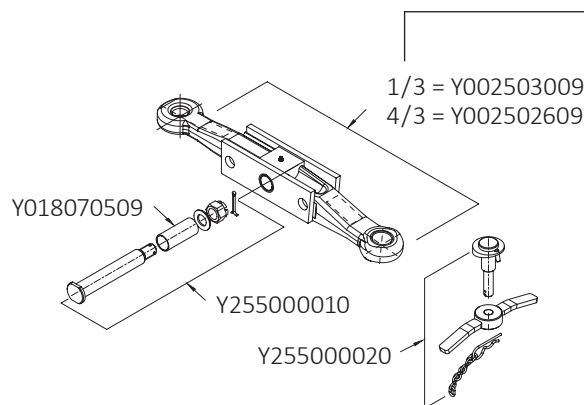

GH

- DE** Höheneinstelleinrichtung, Fixierung durch Klemmung
- EN** Height Adjustment System, fixed using clamps
- FR** Dispositifs d'ajustement de la hauteur réglable, fixation par serrage
- IT** Dispositivi di regolazione dell'altezza, fissaggio con bloccaggio
- ES** Mecanismo de regulación de la altura, fijación mediante un terminal

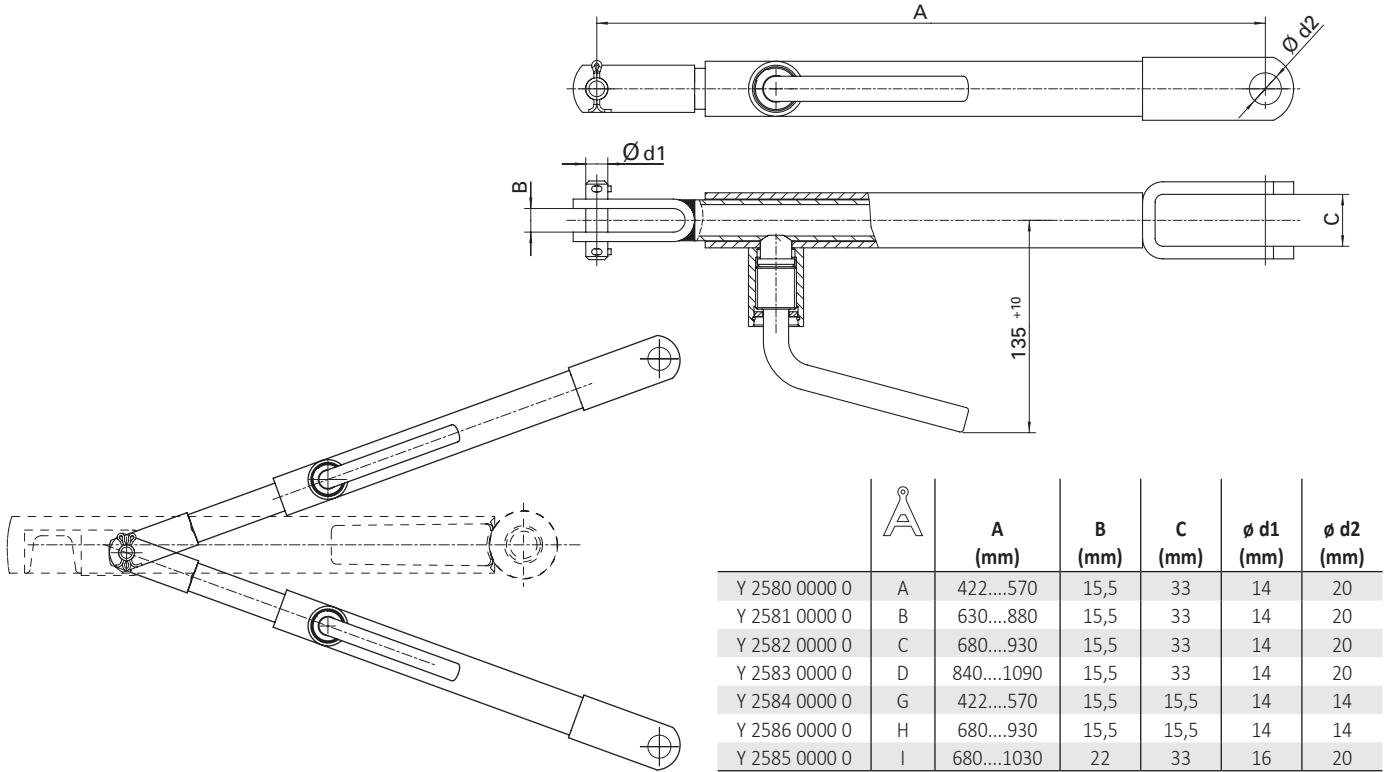

GHE

- DE** Höheneinstelleinrichtung, stufenlos auf Zug einstellbar
- EN** Height Adjustment System, infinitely adjustable by pulling
- FR** Dispositifs d'ajustement de la hauteur réglable, réglable en continu sur traction
- IT** Dispositivi di regolazione dell'altezza, regolazione continua al traino
- ES** Mecanismo de regulación de la altura, ajuste continuo de tracción

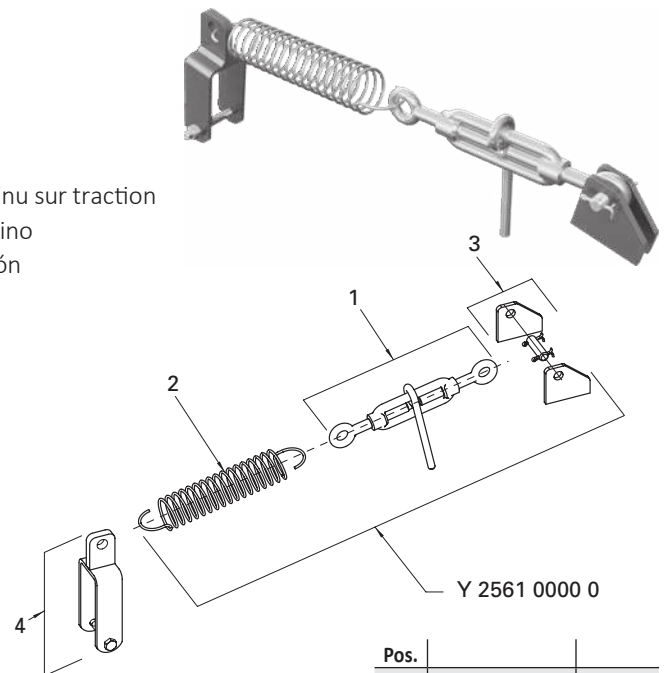
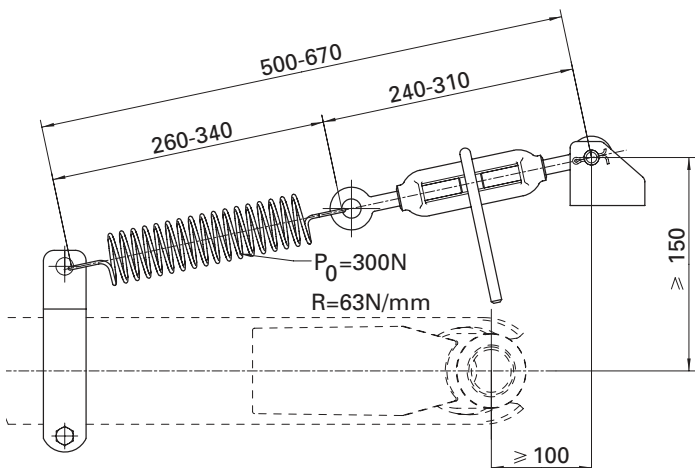

Pos.		
1	Y 2550 0041 0	
2	Y 2550 0042 0	
3	Y 2550 0043 0	
4	Y 2590 0016 1	U 65
4	Y 2590 0017 1	U 80
4	Y 2590 0018 1	U 100

GHD

- DE** Höheneinstelleinrichtung, stufenlos auf Druck einstellbar
- EN** Height Adjustment System, infinitely adjustable by pushing
- FR** Dispositifs d'ajustement de la hauteur réglable, réglable en continu sur tension
- IT** Dispositivi di regolazione dell'altezza, regolazione continua alla pressione
- ES** Mecanismo de regulación de la altura, ajuste continuo de presión

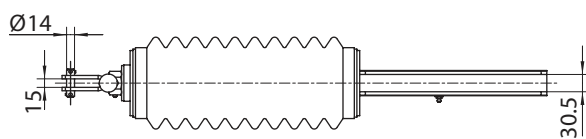
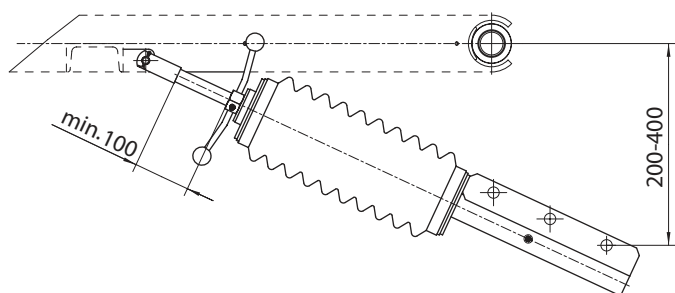
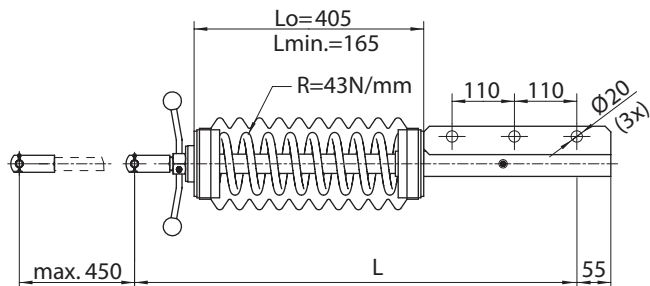

	L
Y 2588 0000 0	780-1230
Y 2588 0001 0	980-1430

- DE** Ersatzteilkit
- EN** Spare parts kits
- FR** Kit de pièces de rechange
- IT** Set di pezzi di ricambio
- ES** Kit de piezas de repuesto

	bestehend aus • consisting of • comprenant • composto da • compuesto por
Y255000600	1x Faltenbalg, 2x Schlauchschelle
	1x Bellows, 2x Hose clamp
	1x Soufflet, 2x Collier de serrage de tuyau
	1x Soffietto, 2x Fascetta tubo
	1x Fuelle, 2x Abrazadera

GZL / GZLG

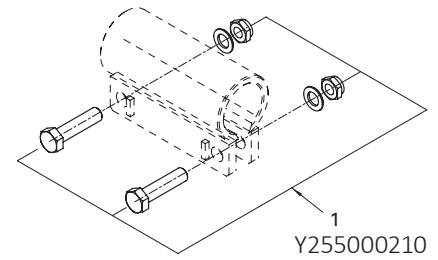
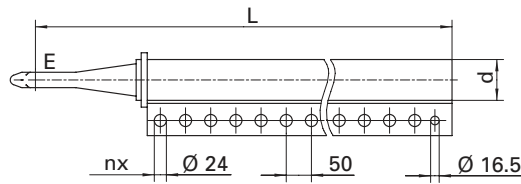

		V (mm)	nx	L (mm)	d (mm)	E (Zugöse • Drawbar eye • Anneaux de remorquage • Occhione di traino • Punta de lanza)
A	Y254000310	12x50	17	1120	81x11	40 DIN 74054
D	Y254000408	12x50	17	1120	81x16	50 ECE
C	Y254000340	12x50	17	1120	81x11	40 CH
S	Y254000409	12x50	17	1120	81x16	57 Skandinavien Zugöse • Skandinavian drawbar eye • Skand. anneau de remorquage • Skand. occhione • Punta de lanza Skand.
L	Y254000390	16x50	21	1320	81x19	40 DIN 74054
P	Y254000393	16x50	21	1320	81x19	40 CH
Z	Y254000382	12x50	17	1120	81x19	68 BNA

GZU / GZHU

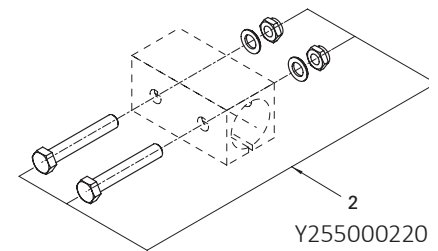
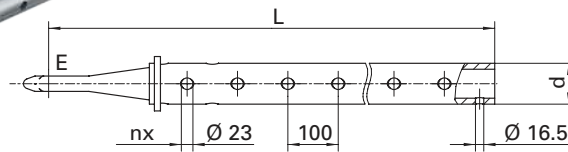

		V (mm)	nx	L (mm)	d (mm)	E (Zugöse • Drawbar eye • Anneaux de remorquage • Occhione di traino • Punta de lanza)	
P	Y254000830	5x100	7	975	81x19	40 DIN 74054	
A	Y254000700	6x100	8	1075	81x11	40 DIN 74054	A > 1900
K	Y254000800	6x100	8	1075	81x19	40 DIN 74054	A <= 1900
C	Y254000720	6x100	8	1075	81x19	50 ECE	
F	Y254000740	8x100	10	1275	81x19	40 DIN 74054	

GZHL

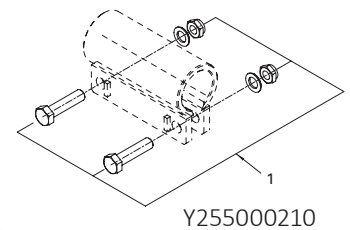
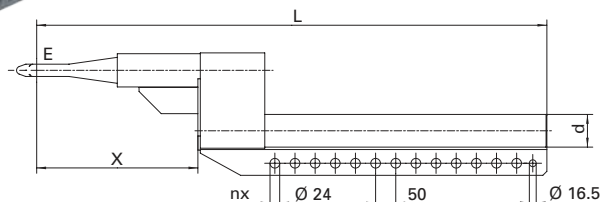

		V (mm)	nx	L (mm)	d (mm)	E (Zugöse • Drawbar eye • Anneaux de remorquage • Occhione di traino • Pwwunta de lanza)	
A	Y254000420	12x50	17	1266	81x19	40 DIN 74054 (X = 200)	A <= 1250
C	Y254000430	12x50	17	1466	81x19	40 DIN 74054 (X = 400)	A > 1250

Weitere Ausführungen auf Anfrage. • More models upon request. • Informations supplémentaires sur demande. • Altre versioni su richiesta. • Más modelos sobre pedido.

Ersatzteile und Zubehör • Spare parts and accessories • Pièces détachées et accessoires • Parti di ricambio e accessori • Piezas de recambio y accesorios

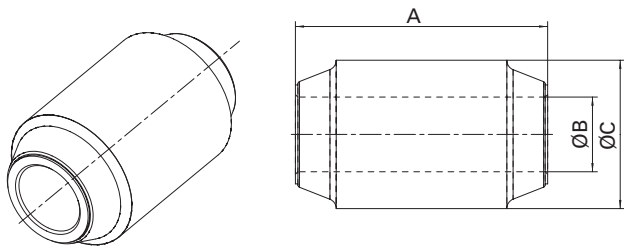

Ersatzteile und Zubehör • Spare parts and accessories • Pièces détachées et accessoires • Parti di ricambio e accessori • Piezas de recambio y accesorios

	A (mm)	B (mm)	C (mm)
Y 059037009	82	30	60,3
Y 059037109	102	30	60,3
Y 059037209	102	32	60,3

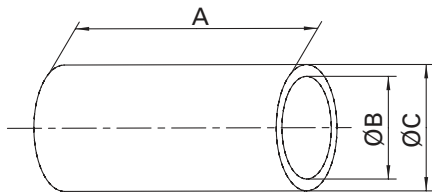

Lagerbuchsen: (Messing) • Bearing bushes: (brass) • Douilles de palier: (laiton) • Gusci di cuscinetto: (in ottone) • Casquillos de cojinete: (latón)

	A (mm)	B (mm)	C (mm)
Y 018035509	70	26	32
Y 018018409	80	28	34
Y 018018509	100	30	36
Y 018039109	100	32	38
Y 018042509	100	40	45
Y 018075509	80	26	32

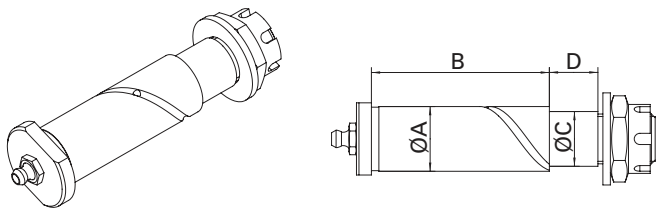

Lagerbolzen Form A: (abgesetzt) • Bearing bolt form A: (extended with different diameter) • Axe de crochet A: (étagé) • Perno ganascia forma A: (fissato) • Bulón de articulación forma A: (recortado)

	A (mm)	B (mm)	C (mm)	D (mm)
Y 016388009	70	26	92,5	22
Y 016388109	80	28	107,5	24
Y 016388209	100	30	131,5	26

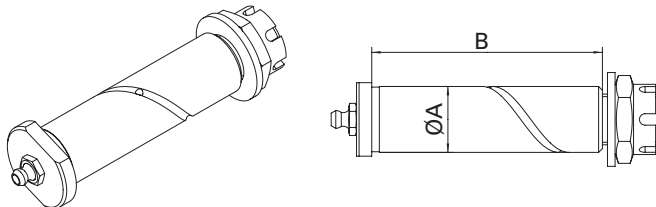

Lagerbolzen Form B • Bearing bolt form B • Axe de crochet, forme B • Perno ganascia forma B • Bulón de articulación forma B

	A (mm)	B (mm)
Y 016388309	70	110
Y 016388409	80	130
Y 016388509	100	160
Y 016387009	100	160

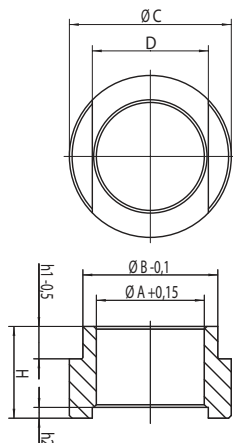

Anschweißaugen • Welding eyes • Oeilletts de soudure • Occhi saldati • Succión de la soldadura

	A (mm)	B (mm)	C (mm)	H (mm)	h1	D	h2
Y 016388609	22	38	42	21	10	–	–
Y 016388709	26	38	42	21	10	–	–
Y 016388809	26	38	42	25	10	29	4
Y 016388909	24	44	48	26	12	–	–
Y 016389009	28	44	48	26	10	–	–
Y 016389109	28	44	48	30	10	31	4
Y 016389209	26	44	50	30	12	–	–
Y 016389309	30	44	50	30	12	–	–
Y 016389409	30	44	50	34	12	33	4
Y 016389509	40	50	55	30	12	–	–
Y 016389609	40	50	55	34	12	43	4

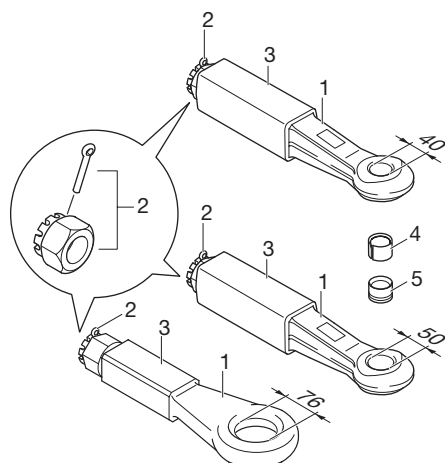

Ersatzteile und Zubehör • Spare parts and accessories • Pièces détachées et accessoires • Parti di ricambio e accessori • Piezas de recambio y accesorios

		∅ (mm)	
1	ROE 57319	40	
1	ROE 57322	50	
1	ROE 57303	76	
2	ROE 56049	40/50/76	
3	ROE 53435	40/50/76	
4	ROE 53051	40	
4	ROE 53004	50	
5	ROE 53386	40	
5	ROE 53376	50	
5	ROE 53556	57,5 R	
5	ROE 53611	57,5 V	

Übermaßbuchsen • Oversize bushes • Douilles à sur-mesure • Bussole maggiorate • Casquillos de sobremedida

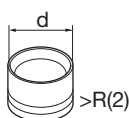

a = 40 mm

	d (mm)	R
ROE 53206	48,5	1
ROE 53207	49	2
ROE 53208	49,5	3
ROE 53209	50	4



a = 50 mm

	d (mm)	R
ROE 53362	60,5	1
ROE 53363	61	2

Prüflehren (Kupplungsbolzen und Zugösen) • Wear gauge (Coupling pin and towing eye) • Gabarits (axes d'accouplement et anneaux de remorquage) • Calibri di controllo (perni e occhioni di traino) • Calibres de referencia (perno de acoplamiento y puntas de lanza)



	(mm)	
ROE 57026	30 (LoF), 40	
ROE 57122	50 (ISO)	
ROE 71354	57	



Montagedorn zum Ein- und Ausschlagen von Zugösenbuchsen • Mounting tool for hammering in and removing towing eye bushes • Broche de montage pour enfoncer et ressortir les douilles des anneaux de remorquage • Spina di montaggio per inserire e estrarre le bussole dell'occhione • Cuña de montaje para introducir y sacar los casquillos de las puntas de lanza

	∅ (mm)	
ROE 57111	40	
ROE 57228	50	

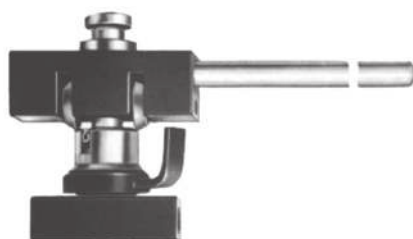

Einroll-Werkzeug für Zugösenbuchsen • Rolling-in device for towing eye bushes • Outil de roulage pour les douilles des anneaux de remorquage • Avvolgitore per le bussole dell'occhione • Herramienta de introducción de casquillos de puntas de lanza

	∅ (mm)	
ROE 57059	40	
ROE 57088	50	

EN Breakdown to Order No.

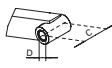
Pos.	1-2: Type	9 + 10: Eye	11: Drawbar eye of non-adjustable drawbars	12: Version
	YA = GNZ 9,4 YB = GNZ 50 HD YC = GNZ 50 YD = GNZ 18 YD = GNZ 18 N YE = GNZ 27 N YF = GNZ 40 YG = GNZ 27 YH = GZU 27 YI = GZHU YJ = GZU 40 A YK = GZU 40 B YL = GZLG YM = GZA 40 YN = GSG YO = GSZ YS = GZL 27 YT = GZL 50 YU = GZHL 30 YV = GZLV YW = GZV YX = GZY 36 YY = GZY 27 YZ = GZY 44	C/D 10 = 60/24 20 = 80/26 30 = 70/26 40 = 80/25 50 = 80/28 60 = 80/30 70 = 100/30 80 = 100/35 90 = 100/30 (Silentbloc) 91 = 100/32 (Silentbloc) 00 = 60/20 01 = 70/24 02 = 60/25 03 = 100/28 04 = 100/32 05 = 70/40 06 = 90/40 07 = 100/40 08 = 90/50 09 = 80/30 (Silentbloc) ON = 100/86-75 (Briab) other models upon request	 0 = without 1 = 40 DIN 74054 A 2 = 50 DIN 74053 A 3 = 50 heavy duty/ECE 4 = 40 CH Swiss drawbar eye 5 = 57 mm Scand. 6 = 76 VG 74059 B 7 = 76 VG 74059 A* 8 = 40 DIN 74054 B* 9 = 40 DIN/50 HD Pivoting drawbar eye E = 50 DIN 74053 B* N = 40 DIN/76 Nato Pivoting drawbar S = 40 CH/50 HD Pivoting drawbar A = 40 DIN 11026 (Lof)** B = 40 DIN – D140 kN** C = KS*80 S = 40 CH – D = 168 kN F = 68 BNA * = convertible M 45 x 3 ** = single approval	0 = Series S = slanted N = Nato K = Kässbohrer G = cranked A = Schmitz 13: Height difference 0 = 0 Serie 0 = 150 Standard * 1 = 100 2 = 200 3 = 300 4 = 250 5 = 350 6 = 400 * cranked version

Example, Order No. (Pos.)

non-adjustable drawbars

YD	210	130	50	1	0	0
1-2	3-5 A (cm)	6-8 B (cm)	9+10	11 E	12	13

adjustable drawbars

YS	190	098	90	T	0	0
1-2	3-5 A (cm)	6-8 B (cm)	9+10	11*	12	13

* Towing pipe of adjustable drawbars

11: Towing pipe of adjustable drawbars

GZU 27	GZU 40 A	GZU 40 B	GZHU	E	V (mm)	GZL 27	GZL 50 A	GZL 50 B	E	V (mm)	GZHL	E	X (mm)	V (mm)	GZV	GZLV	E	
P		-	P	1	5x100	-	H	-	1	8x50	B	1	200	8x50	A <= 1250	A	A	1
T		T	T	3	5x100	-	-	I	2	8x50	A	1	200	12x50	A <= 1250	B	B	2
R5		-	R5	4	5x100	-	K	K	3	8x50	H	3	200	12x50	A <= 1250	D	D	4
L5		L5	L5	5	5x100	-	-	U	2	10x50	I	4	200	12x50	A <= 1250	L	L	5
K (A)		-	K	1	6x100	-	-	B	5	10x50	D	1	400	8x50	A > 1250	F	-	F
C		C	C	3	6x100	A (F)	F	-	1	12x50	L	3	400	8x50	A > 1250			
R (D)		-	R	4	6x100	-	-	T	2	12x50	N	4	400	8x50	A > 1250			
L		L	L	5	6x100	D	D	D	3	12x50	C	1	400	12x50	A > 1250			
Y		-	Y	6	6x100	C (V)	V	-	4	12x50	F	3	400	12x50	A > 1250			
F		-	F	1	8x100	E (S)	S	S	5	12x50	E	4	400	12x50	A > 1250			
H		H	H	3	8x100	J	J	-	6	12x50	K	6	400	12x50	A > 1250			
I		-	I	4	8x100	Z	-	-	F	12x50								
J		J	J	5	8x100	L	L	-	1	16x50								
						-	-	N	2	16x50								
						M	M	M	3	16x50								
						P	P	-	4	16x50								
						Q	Q	Q	5	16x50								

() = A > 1900mm

() = A < 1350

Bestellformular • Order form • Modèle de bon • Modulo per ordine • Formulario de pedido

An • To • À • A • Dirección:

Kunde • Client • Client • Cliente • Cliente:

Wir bestellen per • We order via • Nous passons commande par • Ordiniamo tramite • El pedido se envía por

Nachtexpress • Night express • Messagerie rapide de nuit • Espresso notturno • Servicio de mensajería nocturno

Spedition • Shipping • Transporteur • Spedizioniere • Empresa de transportes

Datum • Date • Date • Data • Fecha:

Unterschrift • Signature • Signature • Firma • Firma:

Anzahl Amount Quantité Quantità Cantidad	Typ Type Type Tipo Tipo	A	B	C	D	Buchsen Messing Sockets Brass Prises Laiton Bussole in ottone Casquillos Latón	Buchsen Silent Sockets Silent Prises Silent Bussole Silent Casquillos Silent	Zugöse E Drawbar eye E Anneau de remorquage E Occhione di traino E Punta de lanza E	H	V

Bemerkung • Remark • Remarque • Nota • Observación

H = Höhenabstand (Bild 1 und 2) • Height difference (image 1 and 2) • Différence de niveau (figures 1 et 2) • Altezza (figure 1 e 2) • Separación vertical (figura 1 y 2)
 V = Verstellbereich (Bild 3) • Extension range (image 3) • Plage de réglage (figures 3) • Range di regolazione (figure 3) • Rango de ajuste (figura 3)

Zugöse schräg • Drawbar eye slanted
 • Anneau de remorquage oblique
 • Occhione di traino inclinato
 • Punta de lanza diagonal

gekröpft • cranked • coudé • piegato a gomito • acodado

verstellbar • adjustable • réglable
 • regolabile • ajustable

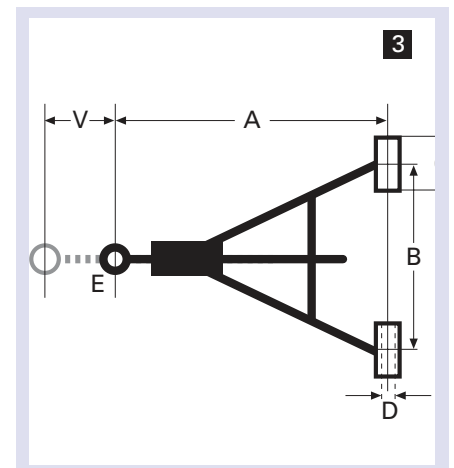
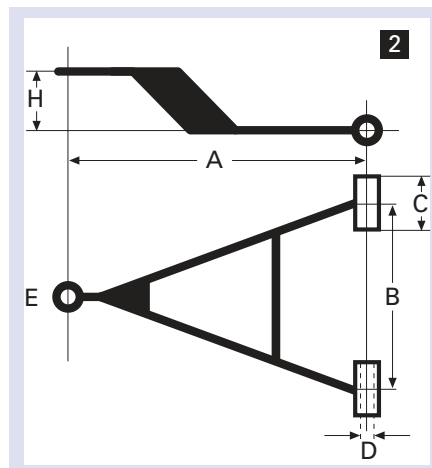
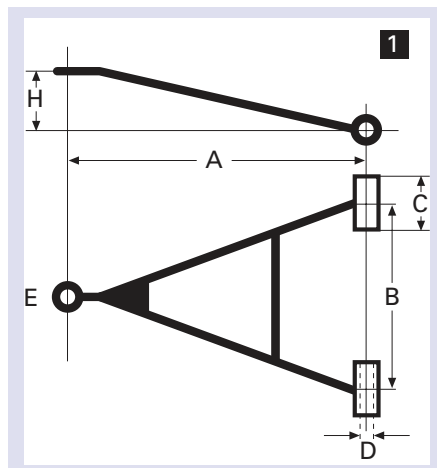

DE Für alle aufgeführten Produkte sind **technische Änderungen** vorbehalten.

EN We reserve the right to make changes to the **technical specifications** of all the products depicted in this catalogue.

FR Tous les produits sont présentés sous réserve de **modifications techniques**.

IT Per tutti i prodotti illustrati ci riserviamo il diritto di apportare **modifiche tecniche**.

ES Respecto a todos los productos indicados se reservan **modificaciones técnicas**.



Transport

JOST

1-3 Systeme

Systems
Systèmes
Sistemi
Sistemas

1 Sattelkupplungen

Fifth wheel couplings
Sellettes d'attelage
Ralle a perno
Quintas ruedas

2 Königszapfen

King pins
Pivots d'attelage
Perni ralla
Pivotes de trole

3 Stützwinden

Landing gears
Béquilles
Sollevatori telescopici
Dispositivos de apoyo

4 Truck- und Trailerachsen

Truck and Trailer axles
Essieux de tracteurs et de remorques
Assali per autoarticolati e rimorchi
Ejes para camiones y remolques

5 Hubodometer

Hubodometers
Hubodomètres
Contachilometri
Hubodómetros

6 Kugellenkränze

Ball bearing turntables
Ronds d'avant train à billes
Ralle a sfera
Coronas de dirección de bolas

7 Containertechnik

Container technology
Porte-conteneurs
Tecnica per container
Técnica de contenedores

TRIDEC

8 Lenksysteme

Steering systems
Systèmes de direction
Impianti sterzanti
Sistemas de dirección

9 Achsaufhängungen

Axle suspensions
Suspension d'essieux
Sospensioni assali
Suspensiones de ejes

Edbro

10 Hydraulikzylinder

Hydraulic cylinders
Cylindres hydrauliques
Cilindri idraulici
Cilindros hidráulicos

11 Hydraulische Zugmaschinenausrüstungen

Hydraulic component kits
Kits hydrauliques
Kits idraulici
Kits hidráulicos

ROCKINGER

12 Anhängerkupplungen

Towing hitches
Crochets d'attelages
Ganci di Traino
Enganches para remolque

13 Zuggabeln und Zugösen

Drawbars and towing eyes
Flèches et anneaux de remorquages
Timoni e occioni di traino
Barras ahorquilladas de tracción
y puntas de lanza

Agriculture

JOST

6 Kugellenkränze

Ball bearing turntables
Ronds d'avant train à billes
Ralle a sfera
Coronas de dirección de bolas

TRIDEC

Achsaufhängungen

Axle suspensions
Suspension d'essieux
Sospensioni assali
Suspensiones de ejes

ROCKINGER

14 Anhängesysteme

Coupling systems
Systèmes d'accouplement
Sistemi di accoppiamento
Sistemas de acoplamiento

13 Zuggabeln und Zugösen

Drawbars and towing eyes
Flèches et anneaux de remorquages
Timoni e occioni di traino
Barras ahorquilladas de tracción
y puntas de lanza

Quicke

15 Frontlader und Arbeitsgeräte

Front loader and implements
Chargeur frontal et outils
Caricatore frontale e attrezzi
Cargador frontal e implementos