

ROCKINGER

Produkte für Nutzfahrzeuge

- ⓔ Products for commercial vehicles
- ⓕ Produits pour véhicules commerciaux
- Ⓜ Prodotti per veicoli commerciali
- ⓔ Gama de productos para vehículos industriales

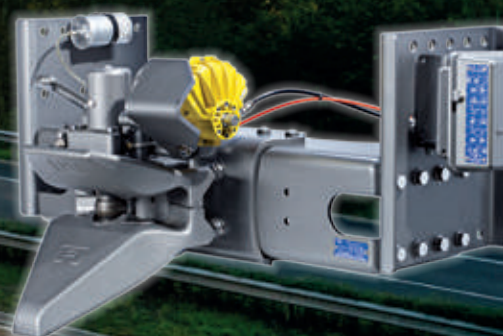
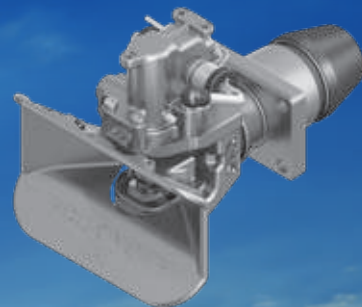

- DE** Produkte für Nutzfahrzeuge
- EN** Products for commercial vehicles
- FR** Produits pour véhicules commerciaux
- IT** Prodotti per veicoli commerciali
- ES** Gama de productos para vehículos industriales

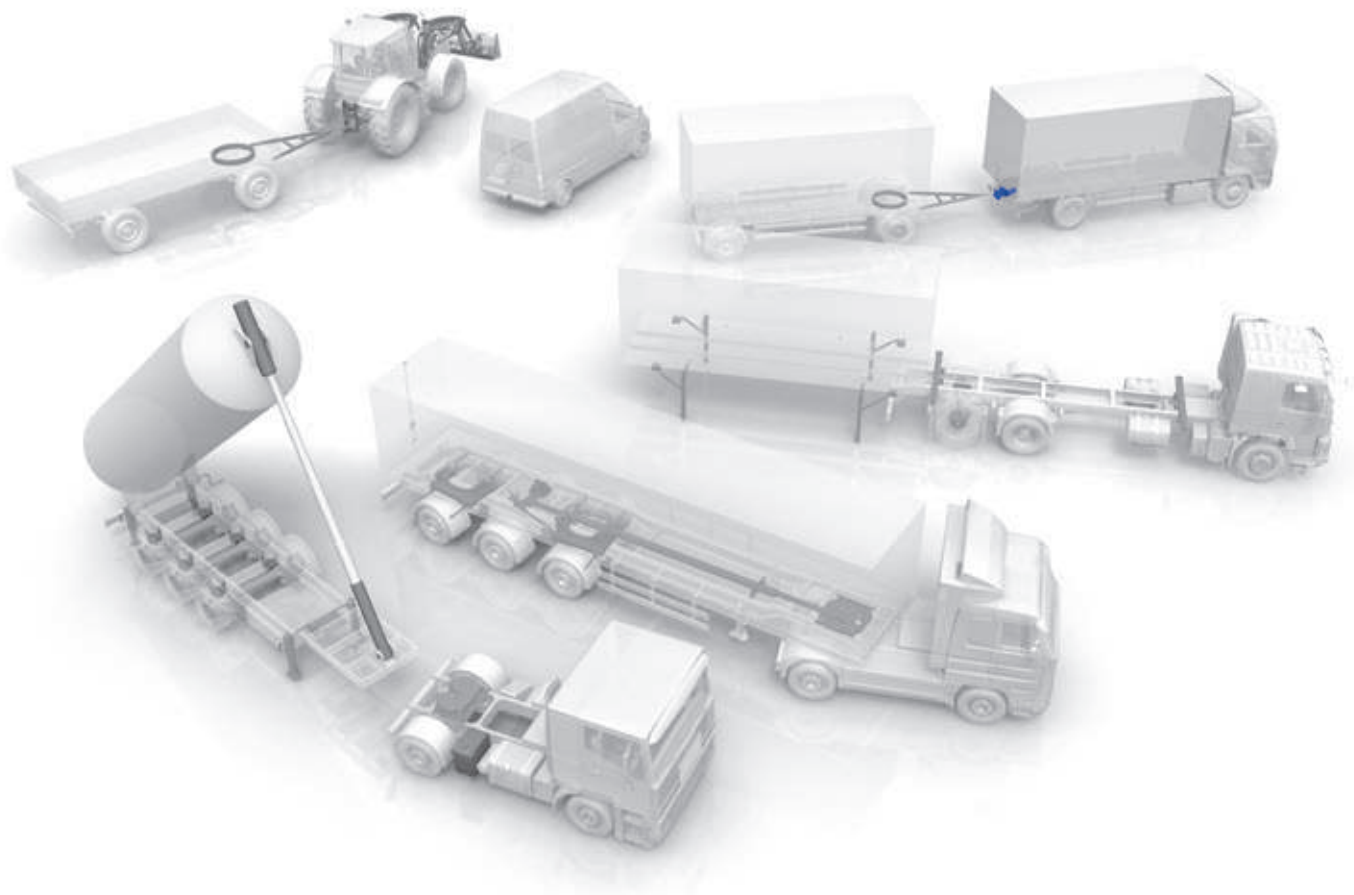

1
 Anhängerkupplungen
 Towing hitches
 Crochets d'attelages
 Ganci di Traino
 Enganches para remolque



2
 Hakenkupplung
 Pintle Hook
 Crochet d'attelage
 Gancio a uncino
 Gancho con almohadillas



3
 Traversen
 Traverse
 Traverses
 Traverss
 Traversaño

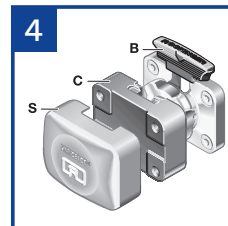

4
 VARIOBLOC
 VARIOBLOC
 VARIOBLOC
 VARIOBLOC
 VARIOBLOC



5
 Zugösen
 Towing eyes
 Anneaux de remorquage
 Occhioni di traino
 Puntas de lanza

DE JOST World: Ein starkes Team

JOST ist ein führender globaler Hersteller und Lieferant von sicherheitsrelevanten Systemen für die Nutzfahrzeugindustrie. Die fünf starken Marken JOST, ROCKINGER, TRIDEC, Edbro und Quicke sind für ihre intelligenten Lösungen und Produktinnovationen bekannt.

Ob Standard-Anhängekupplung oder sensorgesteuerte, fernbedienbare Komfortkupplung: Die Traditionsmarke ROCKINGER bietet ein außerordentlich vielseitiges, hochwertiges und zuverlässiges Produktportfolio und wird von Endanwendern regelmäßig als „Beste Marke im Bereich Anhängerkupplungen“ ausgezeichnet. ROCKINGER gehört seit 2001 zu JOST.

EN JOST World: A strong Team

JOST is a leading global manufacturer and supplier of safety-relevant systems for the commercial vehicle industry. The five strong brands JOST, ROCKINGER, TRIDEC, Edbro and Quicke are well-known for their intelligent solutions and product innovations.

Be it standard towing hitches or sensor- and remote-controlled comfort couplings, the long-established ROCKINGER brand offers an extremely versatile, high-quality and reliable product portfolio and is regularly named the best brand in the towing hitches sector by end customers. ROCKINGER has been part of the JOST World since 2001.

FR JOST World: Une équipe forte

JOST est le fabricant et fournisseur leader mondial de systèmes de sécurité de l'industrie des véhicules utilitaires. Les cinq marques principales : JOST, ROCKINGER, TRIDEC, Edbro et Quicke, sont connues pour leurs solutions intelligentes comme pour leurs produits innovants.

Que ce soit pour les attelages de remorque traditionnels ou bien pour ceux plus modernes guidés par capteurs ou bien encore des attelages réalisés avec une télécommande : le portefeuille de la marque de tradition ROCKINGER dispose d'une palette de produits extrêmement riche, sûre et de qualité. Les clients finaux lui décernent couramment le titre de la „meilleure marque du secteur des attelages de remorque“. ROCKINGER appartient à JOST depuis 2001.

IT JOST World: Una squadra forte

JOST è uno dei produttori e fornitori leader al mondo di sistemi di sicurezza per l'industria dei veicoli commerciali. I cinque grandi marchi JOST, ROCKINGER, TRIDEC, Edbro e Quicke sono famosi per le loro soluzioni intelligenti e i loro prodotti innovativi.

Che si tratti di ganci di traino per rimorchi standard o di comodi sistemi di aggancio telecomandabili con sensori, lo storico marchio ROCKINGER vanta una gamma prodotti straordinariamente variegata, pregiata e affidabile e viene regolarmente votato dagli utenti finali come „Miglior marchio di ganci di traino per rimorchi“. ROCKINGER fa parte di JOST dal 2001.

ES JOST World: Un equipo fuerte

JOST es un fabricante y proveedor líder mundial de sistemas relacionados con la seguridad para el sector de los vehículos industriales. Sus cinco sólidas marcas JOST, ROCKINGER, TRIDEC, Edbro y Quicke son famosas por sus soluciones inteligentes y sus productos innovadores.















Ya se busque un enganche de remolques estándar o un acoplamiento cómodo a distancia controlado por sensores, ROCKINGER es una marca tradicional con una gama de productos extraordinariamente amplia, fiable y de alta calidad que frecuentemente es nombrada la „mejor marca en el área de los enganches de remolque“ por los usuarios. ROCKINGER forma parte de JOST desde el año 2001.

JOST, Siemensstraße 2, 63263 Neu-Isenburg – Deutschland
Tel.: +49 6102 295-0, Fax +49 6102 295-298
E-Mail: jost-sales@jost-world.com



















JOST ROCKINGER TRIDEC Edbro Quicke



Anhängerkupplungen • Towing hitches • Crochets d'attelage • Ganci di Traino • Enganches para remorque













DE Serie EN Series FR Série IT Serie ES Serie	für Zugösen for towing eyes pour anneaux per occhioni di traino para puntas de lanza				Genehmigung Homologation Omologation Omologazione Homologación	Beschreibung Anhängerkupplung Description towing hitch Description crochet d'attelage Descrizione ganci di traino Descripción enganche para remorque	Seite Page Page Pagina Página
RO*225 / 227 	ø 40 mm	X	X		ECE R 55-01	UNIMOG UNIMOG UNIMOG UNIMOG	10
RO*226 	ø 40/76 mm	X	X		ECE R 55-01	Off-Road, Vertikalgelenk Off-Road, vertical articulating Off-Road, articulation verticale Off-Road, campana snodata Off-Road, articulación vertical	12
RO*231 	ø 40/76 mm	X	X		ECE R 55-01	Hakenkupplung mit Flansch Hook trailer hitch with flange Accouplement à crochet avec bride Gancio a uncino con flangia Enganche de gancho con brida	14
RO*232 	ø 40/76 mm CH	X	X		ECE R 55-01	Hakenkupplung, gefedert Hook trailer hitch with buffers Accouplement à crochet à ressorts Gancio a uncino molleggiato Enganche de gancho con almohadillas	16
RO*240 	ø 40 mm	X	X		94/20/EC	Drehbar, Transporter Rotable, light trucks Tournant, véhicules utilitaires Girevole, motrici leggere Giratorio, furgonetas	18
RO*243 	ø 40 mm	X	X		ECE R 55-01	Kompakt, Transporter Compact, light trucks Compact, véhicules utilitaires Compatto, motrici leggere Compacto, furgonetas	20
RO*244-2 RO*244-L 	ø 35/40 mm	X	X		ECE R 55-01	Kompakt, Flurförderzeuge Compact, industrial trucks Compact, chariots de manutention Compatto, dibiti a movimentazione Compacto, vehículos industriales	22/23
RO*245 	ø 35/40 mm	X	X			Kompakt, innerbetrieblicher Transport Compact, internal transport Compact, transport inter-usine Compatto, movimentazione interne Compacto, transporte interno	25
RO*253 	ø 40 mm CH	X	X			Drehbar, Transporter Rotable, light trucks Tournant, véhicules utilitaires Girevole, motrici leggere Giratorio, furgonetas	27
RO*256 	ø 40 mm	X	X		ECE R 55-01	Transporter, gefedert Light trucks with buffers Véhicules utilitaires à ressorts Motrici leggere molleggiato Furgonetas con almohadillas	29
RO*290 	ø 40 mm	X				Schienengebundene Arbeitsmaschinen Rail vehicles Machines-outils sur rails Macchine di lavoro su rotaia Máquinas de trabajo sobre carriles	31
RO*40 E 	ø 40 mm	X	X		ECE R 55-01	Vollautomatische Anhängerkupplung Fully automatic towing hitch Crochet d'attelage entièrement autom. Gancio di traino automatico Enganche para remorque total. autom.	33

Anhängerkupplungen • Towing hitches • Crochets d'attélagés • Ganci di Traino • Enganches para remolque

 Serie  Series  Série  Serie  Serie	für Zugösen for towing eyes pour anneaux per occhioni di traino para puntas de lanza	  	Genehmigung Homologation Omologation Omologazione Homologación	Beschreibung Anhängerkupplung Description towing hitch Description crochet d'attelage Descrizione ganci di traino Descripción enganche para remolque	Seite Page Page Pagina Página
RO*40 CH 	ø 40 mm CH ø 40 mm ø 50 mm	x x	ECE R 55-01	Vollautomatische Anhängerkupplung Fully automatic towing hitch Crochet d'attelage entièrement autom. Gancio di traino automatico Enganche para remolque total. autom.	35
RO*400-1 	ø 40 mm	x x	ECE R 55-01	Standard Standard Standard Standard Estándar	37
RO*430 	ø 40 mm	x x	ECE R 55-01	Comfort, spielfrei Comfort, slack-free Confort, sans jeu Comfort, senza gioco Confort, exento de juego	39
RO*433 T1 	ø 40 mm CH	x x		Comfort, spielfrei Comfort, slack-free Confort, sans jeu Comfort, senza gioco Confort, exento de juego	41
50 mm Anhängerkupplungen • 50 mm Towing hitches • 50 mm Crochets d'attélagés • 50 mm Ganci di Traino • 50 mm Enganches para remolque					
RO*50 	ø 50 mm	x x	ECE R 55-01	Vollautomatische Anhängerkupplung Fully automatic towing hitch Crochet d'attelage entièrement autom. Gancio di traino automatico Enganche para remolque total. autom.	43
RO*50 E 	ø 50 mm	x x	ECE R 55-01	Vollautomatische Anhängerkupplung Fully automatic towing hitch Crochet d'attelage entièrement autom. Gancio di traino automatico Enganche para remolque total. autom.	45
RO*50 flex 	ø 50 mm	x	ECE R 55-01	Schwerlast, Off-Road Heavy duty, Off-Road Lourdes charges, Off-Road Traini eccezionali, Off-Road Carga pesada, Off-Road	47
RO*500 	ø 50 mm	x x	ECE R 55-01	Standard G5,G4,G3 Standard G5,G4,G3 Standard G5,G4,G3 Standard G5,G4,G3 Estándar G5,G4,G3	49
RO*530 	ø 50 mm	x x	ECE R 55-01	Comfort, spielfrei Comfort, slack-free Confort, sans jeu Comfort, senza gioco Confort, exento de juego	51
RO*560 	ø 50 mm	x x	ECE R 55-01	mit Flansch with flange avec bride con flangia con brida	53
RO*56 E / 561 	ø 50 mm	x	ECE R 55-01	Schwerlast, Vertikalgelenk Heavy duty, vertical articulating Lourdes charges, articulation verticale Traini eccezionali, campana snodata Carga pesada, articulación vertical	55



Anhängekupplungen • Towing hitches • Crochets d'attelage • Ganci di Traino • Enganches para remolque

DE Serie EN Series FR Série IT Serie ES Serie	für Zugösen for towing eyes pour anneaux per occhioni di traino para puntas de lanza				Genehmigung Homologation Omologation Omologazione Homologación	Beschreibung Anhängerkupplung Description towing hitch Description crochet d'attelage Descrizione ganci di traino Descripción enganche para remolque	Seite Page Page Pagina Página
57 mm Anhängerkupplungen • 57 mm Towing hitches • 57 mm Crochets d'attelage • 57 mm Ganci di Traino • 57 mm Enganches para remolque							
RO*57 	ø 57,5 mm	X	X		ECE R 55-01	Standard Standard Standard Standard Estándar	57
RO*57 flex 	ø 57,5 mm	X			ECE R 55-01	Off-Road Off-Road Off-Road Off-Road Off-Road	59
68 mm Anhängerkupplungen • 68 mm Towing hitches • 68 mm Crochets d'attelage • 68 mm Ganci di Traino • 68 mm Enganches para remolque							
RO*50 BNA 	ø 68 mm	X	X		ECE R 55-01	für BNA-Ringzugösen BNA ring towing eyes pour anneau torique de traction BNA per occhioni BNA para punta de lanza de anillo-BNA	61
80 mm Anhängerkupplungen für Autotransfer • 80 mm Towing hitches for the transportation of cars • 80 mm Crochets d'attelage pour transfert automatique • 80 mm Ganci di Traino per Autotransfer • 80 mm Enganches para remolque para autotransfer							
RO*908 (Typ ROVKU 80) 	ø 80 mm	X	X		ECE R 55-01	Kugelkupplungssystem Ball Coupling System Système d'attelage à boule Sistema gancio a sfera Sistema de enganches esféricos	63
RO*KK370 	ø 50 mm	X	X		ECE R 55-01	Kugelkupplung Ball hitch Attelage à boule Ganci a sfera Enganches esféricos	65
RO*200 					ABG	Zugkugelkupplung Hitch heads Crochet à boule Gancio per accoppiamento Enganches esférico	65
76 mm Hakenkupplung • 76 mm Pintle Hook • 76 mm Crochet d'attelage • 76 mm Gancio a uncino • 76 mm Gancho con almohadillas							
RO*283 	ø 76 mm	X	X			Hakenkupplung Pintle Hook Crochet d'attelage Gancio a uncino Gancho con almohadillas	66
RO*231 	ø 40/76 mm	X	X		ECE R 55-01	Hakenkupplung mit Flansch Hook trailer hitch with flange Accouplement à crochet avec bride Gancio a uncino con flangia Enganche de gancho con brida	14/68
RO*232 	ø 40/76 mm CH	X	X		ECE R 55-01 e1-1350-02	Hakenkupplung, gefedert Hook trailer hitch with buffers Accouplement à crochet à ressorts Gancio a uncino molleggiato Enganche de gancho con almohadillas	16/70

Zubehör Anhängerkupplungen • Accessories Towing hitches • Accessoires Crochets d'attelages • Accessori Ganci di Traino • Accesorios Enganches para remolque

DE Serie	für Zugösen			Genehmigung	Beschreibung Anhängerkupplung	Seite
EN Series	for towing eyes			Homologation	Description towing hitch	Page
FR Série	pour anneaux			Omologazione	Description crochet d'attelage	Page
IT Serie	per occhioni di traino			Omologación	Descrizione ganci di traino	Página
ES Serie	para puntas de lanza				Descripción enganche para remolque	Página

Abschleppkupplung • Shunting coupling • Chapes de remorquage • Ganci di manovra • Enganches para remolcar

RO*205 / 207 / 230 	ø 40 mm ø 50 mm ø 76 mm			EU VO Nr. 1005/2010	Abschleppkupplung Shunting coupling Chapes de remorquage Ganci di manovra Enganches para remolcar	72
--	-------------------------------	--	--	------------------------	---	----

Traversen • Traverse • Traverses • Traverss • Traversaño

Traverse RO*CM 75-2 		x	x	ECE R 55-01	Traversen Traverse Traverses Traversa Travesañó	75
---	--	---	---	----------------	---	----



VARIOBLOC • VARIOBLOC • VARIOBLOC • VARIOBLOC • VARIOBLOC

VARIOBLOC RO*100 		x	x	ECE R 55-01	VARIOBLOC VARIOBLOC VARIOBLOC VARIOBLOC VARIOBLOC	77
--	--	---	---	----------------	---	----

Adapterkupplungen • Adapter hitches • Crochets d'adaptation • Adattatori • Enganches adaptadores

RO*480 / 483 / 580 	ø 40/50 mm	x			Adapterkupplungen, selbsttätig Adapter hitches, automatic Crochets d'adaptation, automatiques Adattatori, automatici Enganches adaptadores, automáticos	80
--	------------	---	--	--	---	----

Zugösen • Towing eyes • Anneaux de remorquage • Occhioni di traino • Puntas de lanza

	ø 40/50/57,5 mm	x	x	ECE R 55-01 94/20/CE	Zugösen Towing eyes Anneaux de remorquage Occhioni di traino Puntas de lanza	82
					Prüflehren Wear gauges Calibres de contrôle Calibri Patrones de comprobación	85

	Aufrüstsätze Upgrade kits kits d'équipement Kit complementari Juegos de equipamiento posterior				Fernanzeigen- und bedienungen, Warnanzeigen • Remote controls, remote displays, warning systems • Commandes, affichages à distance, avertisseurs • Segnalatori apertura/chiusura e telecomandi, spie di segnalazione • Teleindicaciones y telemandos, mensajes de advertencia	86
---	--	--	--	--	---	----

	Zubehör Accessories Accessoires Accessori Accesorios				Werkzeuge • Tools • Outils • Attrezzi • Herramientas Schraubensätze • Screw sets • Kits de vis • Kit di viti • Juegos de tornillos	85 97
---	--	--	--	--	---	----------

	Berechnung Calculation Calcul Calcolo Cálculo					98
---	---	--	--	--	--	----



Verwendete Piktogramme • Used pictographs • Pictogrammes utilisés • Pittogrammi utilizzati • Pictogramas empleados

DE EN FR IT ES	Icon Series Série Serie Serie	Beschreibung Description Description Descrizione Descripción
		Handhebelposition Hand lever position Position du levier à main Posizione della leva manuale Posición de la palanca de mano
		Kupplungsgröße Hitch size Dimension du crochet Dimensioni del gancio Tamaño del enganche
		Lochbild Hole pattern Schéma de perçage Interassi dei fori di fissaggio Disposición de agujeros
		Starrdeichselanhänger Centre axle trailers Remorques à essieu central Rimorchi con asse centrale Remolques con eje central
		zulässige Vorderachslast des Drehschemels Permissible front load of the turning steering frame Charge avant admise de la selle orientable Carico anteriore autorizzato della ralla Carga delantera permitida del pivote bastidor
		Summe der Achslasten Sum of axle loads Somme de charges sur l'essieu Somma dell a dei carichi assiali Suma de la cargas de los ejes
		D-Wert VARIOBLOC D-value VARIOBLOC Valeur D VARIOBLOC Valore D VARIOBLOC Valor D VARIOBLOC
		Dc-Wert VARIOBLOC Dc-value VARIOBLOC Valeur Dc VARIOBLOC Valore Dc VARIOBLOC Valor Dc VARIOBLOC
		Starrdeichselanhänger Centre axle trailer Remorque fixe Rimorchio a timone rigido Remolque de barra de tracción fija
		Gelenkdeichselanhänger Drawbar trailer Remorque articulée Rimorchio con timone snodato Remolque de barra de tracción articulada
		Zugfahrzeug Truck Poids du véhicule tracteur Motrice Vehículo tractor
		Stahlguss-Fangmaul Funnel in cast steel Pavillon en acier moulé Testa campana in acciaio fuso Boca de enganche acero fundido

DE EN FR IT ES	Icon Series Série Serie Serie	Beschreibung Description Description Descrizione Descripción
		Position langes Fangmaul Long jaw position Position pavillon long Posizione bocca di aggancio lunga Posición boca de enganche larga
		VARIOBLOC VARIOBLOC VARIOBLOC VARIOBLOC VARIOBLOC
		Kupplungskugel Hitch ball Boule d'attelage Gancio a sfera Enganche de bola
		Kupplungsbolzen Hitch pin Boulon d'accouplement Perno Perno de acoplamiento
		Steckbolzen Insert hitch pin Axe embrochable Perno Perno enchufable
		Zugöse Towing eye Anneau de remorquage Occhione di traino Punta de lanza
		Zugöse \varnothing Towing eye \varnothing Anneau de remorquage \varnothing Occhione di traino \varnothing Punta de lanza \varnothing
		Anschraubplatte Plate of bolting Platine à boulonner Piastra di fissaggio Plancha roscable
		Gewicht Weight Poids Peso Peso
		Seitenanschlag RO*57 Protection stop RO*57 Taquet latéral RO*57 Guida di appoggio RO*57 Tope lateral RO*57
		elektr. Fernanzeige Kabine In-cab status indicator Affichage à distance Segnalatore apertura/chiusuraa Teleindicación
		elektronische Fernanzeige Kabine In-cab status indicator Affichage à distance Segnalatore apertura/chiusuraa Teleindicación

Verwendete Piktogramme • Used pictographs • Pictogrammes utilisés • Pittogrammi utilizzati • Pictogramas empleados

DE Icon EN Series FR Série IT Serie ES Serie	Beschreibung Description Description Descrizione Descripción
	Schwenkwinkel Warnanzeige Drawbar turn angle warning system Voyant pour l'angle de rotation Indicatore di emergenza angolo di rotazione Indicador de advertencia del ángulo de giro
	pneumatische Fernbedienung, Komfort pneumatic remote control, comfort commande pneumatique à distance, confort comando pneumatico a distanza, confort mando a distancia neumático, confort
	pneumatische Fernbedienung, Einfach mit Duomatic-Anschluss Pneumatic remote control, light with Duomatic plug Commande à distance pneumatiques, standard avec connecteur Duomatic Comandi pneumatici da remoto, semplice con spina Duomatic Control remoto neumático, sencillo con conector Duomatic
	mechanische Fernbedienung, Standard mechanical remote control, standard commande mécanique à distance, standard azionamento a distanza meccanico, standard teleaccionamiento mecánico, estándar
	elektropneumatische Fernbedienung, Komfort electro-pneumatic remote control, comfort commande à distance électropneumatique, confort comando elettropneumatico a distanza, confort mando a distancia electroneumático, confort
	Klemmlänge: K + L Grip: K + L Longueur de serrage: K + L Lunghezza di serraggio: K + L Longitud de apriete: K + L
	Menge Quantity Quantité Quantità Cantidad
	Zugfahrzeug, Schiene Truck, rail Poids du véhicule tracteur, rail Motrice, guida Vehículo tractor, carril
	Befestigungslager Attachment bearing Palier de fixation Cuscinetto di fissaggio Cojinetes de sujeción
	Befestigungssatz Mounting kit Kit de fixation Kit di fissaggio Conjunto de fijación
	Anziehdrehmoment Torque Couple de serrage Coppia di serraggio Par de apriete

DE Icon EN Series FR Série IT Serie ES Serie	Beschreibung Description Description Descrizione Descripción
T	Traverse Cross member Traverse Traversa Travesaño
K	Traversendicke Thickness of cross member Épaisseur de la traverse Spessore traversa Grosor del travesaño



RO★225 / 227 – 40 mm

- DE** Sonderkupplungen
- EN** Special hitch
- FR** Crochets d'attelage spéciaux
- IT** Ganci speciali
- ES** Enganches especiales

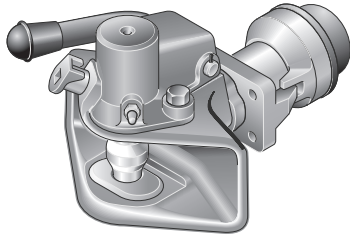

a = 40 mm, DIN 74054,
ECE, Nato VG 74054

225G110A, 227G110Q
für Zugöse CH
for towing eye CH
pour anneau de remorquage CH
per occhione di traino CH
para punta de lanza CH

- DE** Für Kraftfahrzeuge DIN 74051, Fußnote 3/StVZO § 43 Abs. 4.
Auch zum Anbau an Anhänger zugelassen
Fangmaulgröße 100 mm x 200 mm
- EN** Admissible for mounting to the trailer
Funnel size 100 mm x 200 mm
- FR** Agréé également pour installation sur une remorque
Dimension du pavillon 100 mm x 200 mm
- IT** Omologato anche per l'applicazione su rimorchi
Dimensioni testa campana 100 mm x 200 mm
- ES** También autorizado para el montaje en el remolque
Tamaño de boca de enganche 100 mm x 200 mm

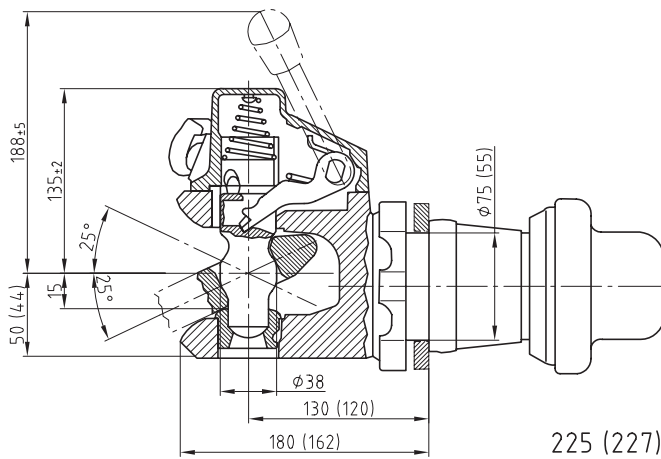

225 (227)

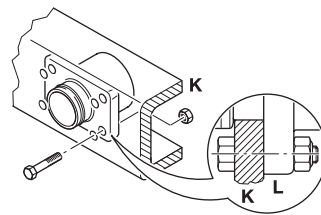
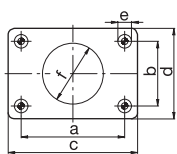
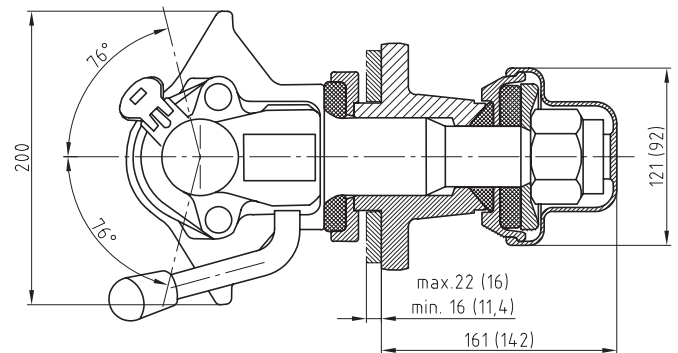

	a (mm)	b (mm)	c (mm)	d (mm)	e (mm)	f (mm)
112	120,0	55,0	155,0	90,0	15,0	75,0
111	83,0	56,0	110,0	85,0	10,5	55,0

	K (mm)	K (mm)
112	max. 22	max. 22
111	11-16	11-16

Technische Daten • Technical data • Données technique • Dati tecnici • Datos técnicos



										ECE
	A	B	(mm)	D (kN)	Dc (kN)	S (kg)	V (kN)	C (t)	(kg)	
RO 225G110	A	B	112	85	68,4	1500	24,0	10	17,4	E1 55R-01 0050
RO 225G110A (CH)	A	B	112	85	68,4	1500	24,0	10	17,4	
RO 227G110J	C	B	111	66	66,0	1250	14,0	5	12,4	E1 55R-01 0049
RO 227G110Q (CH)	C	B	111	66	66,0	1250	14,0	5	12,4	

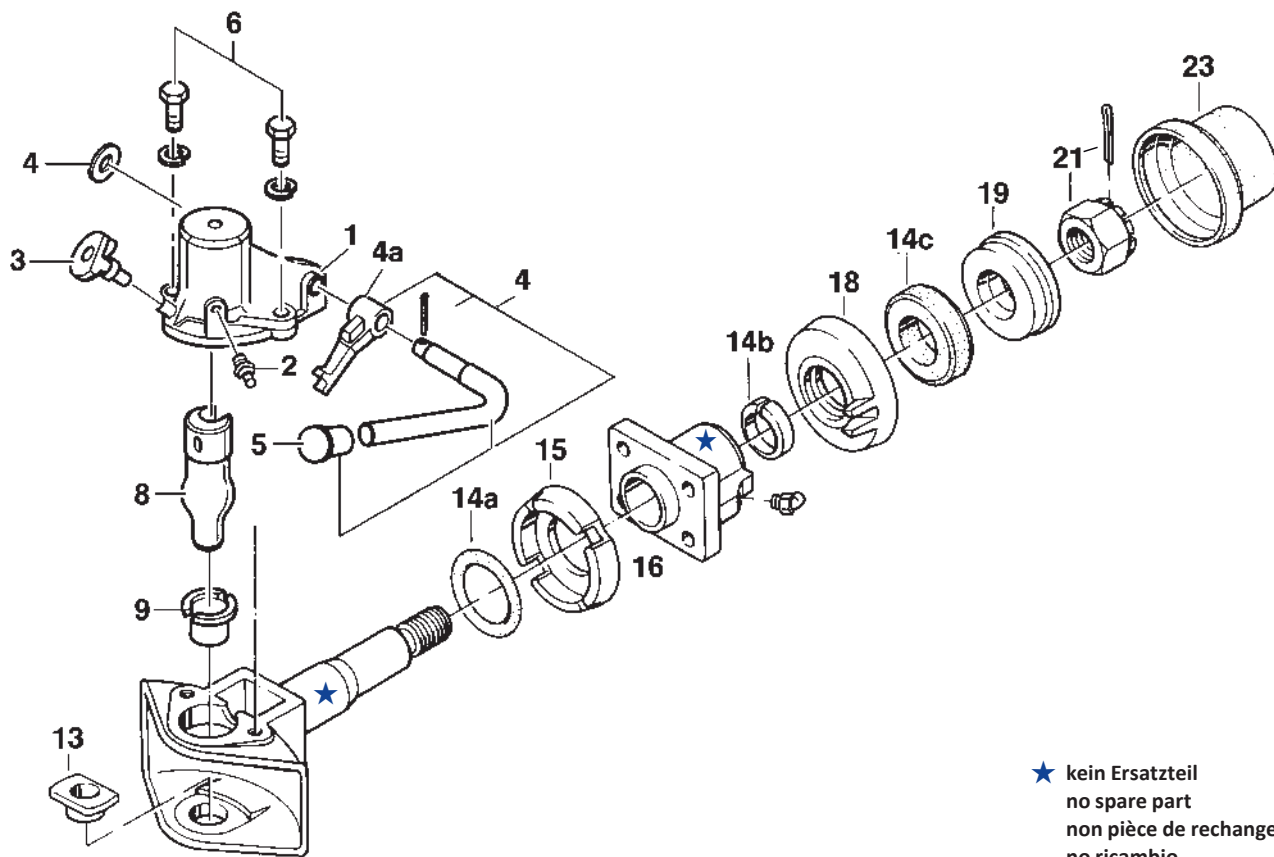

RO★225 / 227

Ersatzteile • Spare parts • Pièces de rechange • Ricambi • Piezas de recambio

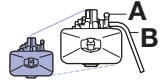

★ kein Ersatzteil
no spare part
non pièce de rechange
no ricambio
no es pieza de recambio

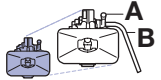
Pos		ROE	
01	227 (110 J)	ROE 66392	1
01	225 (110)	ROE 67101	1
01	225 (110 A), 227 (110 Q)	ROE 66466	1
02	227	ROE 65018	1
02	225	ROE 65018	1
03		ROE 66242	1
04		ROE 70723	1
04		ROE 50102	1
05		ROE 25105	1
06		ROE 70173	1
08	225 (110), 227 (110 J)	ROE 47013	1
08	225 (110 A), 227 (110 Q)	ROE 47031	1
09		ROE 53029	1
13		ROE 53030	1
14	227	ROE 70172	1
14	225	ROE 67056	1
15	227 (110)	ROE 54420	1
15	225 (110)	ROE 54472	1

Pos		ROE	
16		ROE 39124	1
18	225 (110)	ROE 44073	1
18	227 (110)	ROE 44075	1
19	225 (110)	ROE 54372	1
19	227 (110)	ROE 54471	1
20	225	ROE 65018	1
20	227	ROE 65019	1
21	225	ROE 56028	1
21	227	ROE 56118	1
23	225	ROE 25076	1
23	227	ROE 25093	1

RO*226 – 40 mm / 76 mm

- DE** Schlechtweggekuppung
- EN** Off road hitch
- FR** Crochet d'attelage pour voies en mauvais état
- IT** Gancio per sollecitazioni gravose
- ES** Enganche para carreteras en mal estado

- DE** für Fahrzeuge mit Spezialaufbau, z. B. Feuerwehrfahrzeuge, geländegängig, mit Vertikalgelenk
- EN** for vehicles with special body construction, e. g. fire engines, for cross-country operation, vertical articulating hitch head
- FR** pour véhicules à carrosserie spéciale, par ex. véhicules de pompiers, tout terrain, à articulation verticale
- IT** per veicoli con allestimenti speciali, per esempio veicoli antincendio, veicoli per fuoristrada, con campana snodata
- ES** para vehículos con construcción especial, p. ej., vehículos de bomberos, todo terreno, con articulación vertical

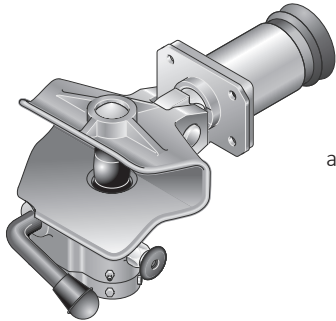

a = 40 mm DIN 74054
94/20/CE
für Zugöse CH
for towing eye CH
pour anneau de remorquage CH
per occhione di traino CH
para punta de lanza CH
a = 76 mm
VG 74059 NATO

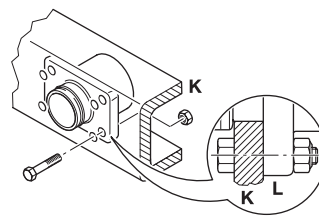
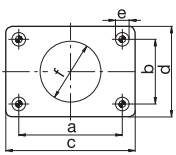
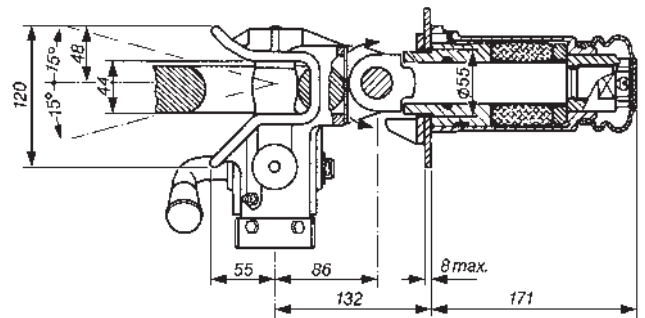
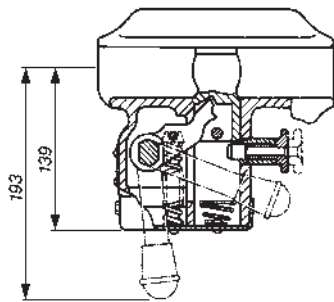
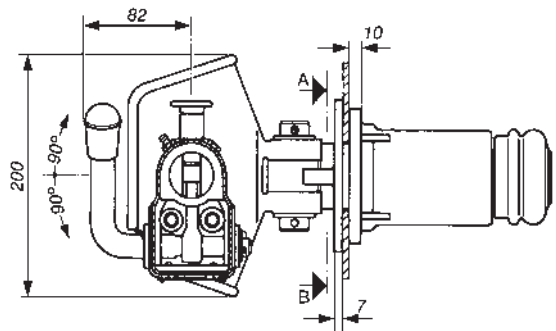

	a (mm)	b (mm)	c (mm)	d (mm)	e (mm)	f (mm)
210	83,0	56,0	125,0	83,0	10,5	55,0

	K (mm)	K (mm)
210	8	8

Technische Daten • Technical data • Données technique • Dati tecnici • Datos técnicos

										ECE
RO 226G210A	B	210	83 x 56	66	18,5	50	5,0	-	13,0	E1 55R-01 0799
RO 226G210A	B	210	83 x 56	66	-	80 ¹	-	2 ¹	13,0	E1 55R-01 0799

¹ für Feuerwehr- und Katastrophenfahrzeuge, for special emergency vehicles, pour véhicules de secours spéciaux, per veicoli speciali di emergenza, para vehículos especiales de emergencia

RO★226

Ersatzteile • Spare parts • Pièces de rechange • Ricambi • Piezas de recambio

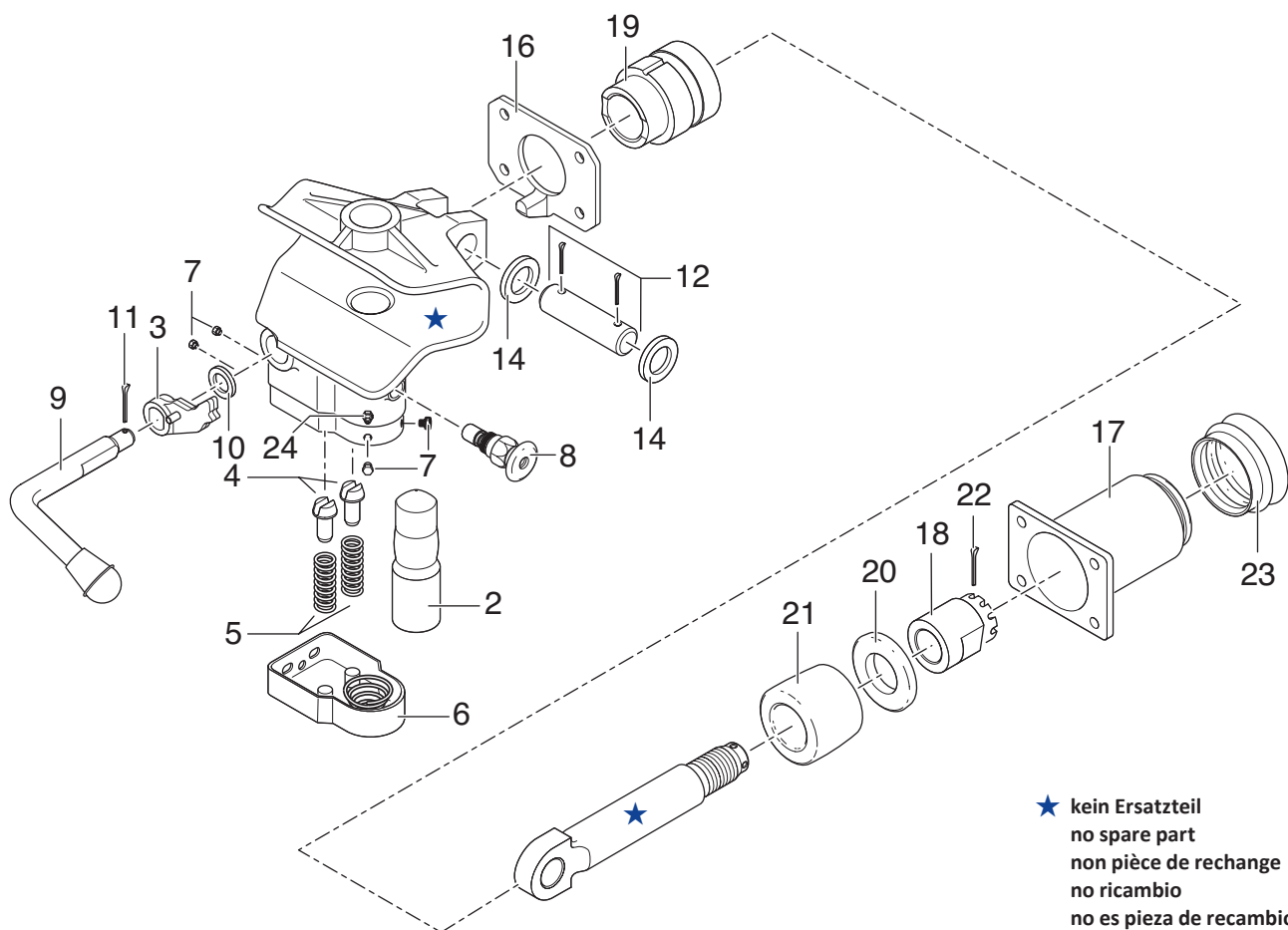

Pos		ROE	
02		ROE 47006	1
03		ROE 51017	1
04		ROE 13001	2
05		ROE 55029	2
06		ROE 65005	1
07		ROE 70331	1
08		ROE 70356	1
09		ROE 50083	1
10		ROE 33011	1
11		ROE 35013	1
12		ROE 65090	1
14		ROE 54001	2

Pos		ROE	
16		ROE 54002	1
17		ROE 44021	1
18		ROE 56009	1
19		ROE 53027	1
20		ROE 54072	1
21		ROE 25012	1
22		ROE 35002	1
23		ROE 25008	1
24		ROE 65018	1

RO★231 – 76 mm / 40 mm

- DE** Hakenkupplung mit Sicherungsstecker im Verschlussbügel
- EN** Hook trailer hitch with safety lock
- FR** Accouplement à crochet avec fiche de sécurité dans l'étrier de verrouillage
- IT** Gancio a uncino con spinotto di sicurezza nella staffa di chiusura
- ES** Enganche de gancho con dispositivo de seguridad en el estribo de cierre

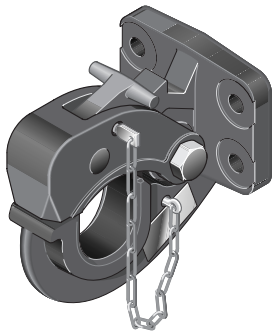

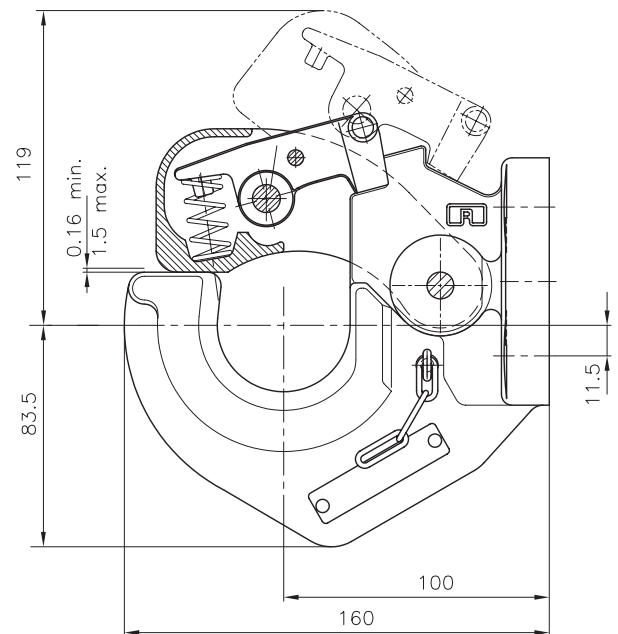
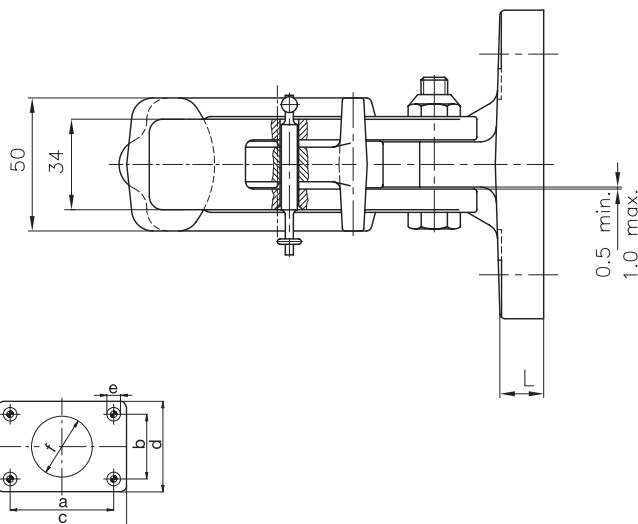

RO 231xx00x
a = 76 mm, VG 74059 NATO

RO 231xx53x
a = 40 mm, DIN 74054, 94/20/CE,
für Zugöse CH
for towing eye CH
pour anneau de remorquage CH
per occhio di traino CH
para punta de lanza CH



	a (mm)	b (mm)	c (mm)	d (mm)	e (mm)	L (mm)
05	86,0	45,0	116,0	85,0	13,0	16
11	83,0	56,0	116,0	85,0	10,5	16

Technische Daten • Technical data • Données technique • Dati tecnici • Datos técnicos



C D	A B		D (kN)	Dc (kN)	S (kg)	V (kN)	C (t)		ECE
RO 231A05000	05	86 x 45	25	22	250	14,4		5,0	-
RO 231A05090	05	86 x 45	25	22	250	14,4		5,0	-
RO 231A05530	05	86 x 45	20	18	150	9,6		3,6	-
RO 231A05531	05	86 x 45	20	18	150	-	3,5	3,6	E1 55R-01 1958
RO 231A11000	11	83 x 56	25	22	250	14,4		5,0	-
RO 231A11530	11	83 x 56	20	18	150	9,6		3,6	-
RO 231A11531	11	83 x 56	20	18	150	-	3,5	3,6	E1 55R-01 1958

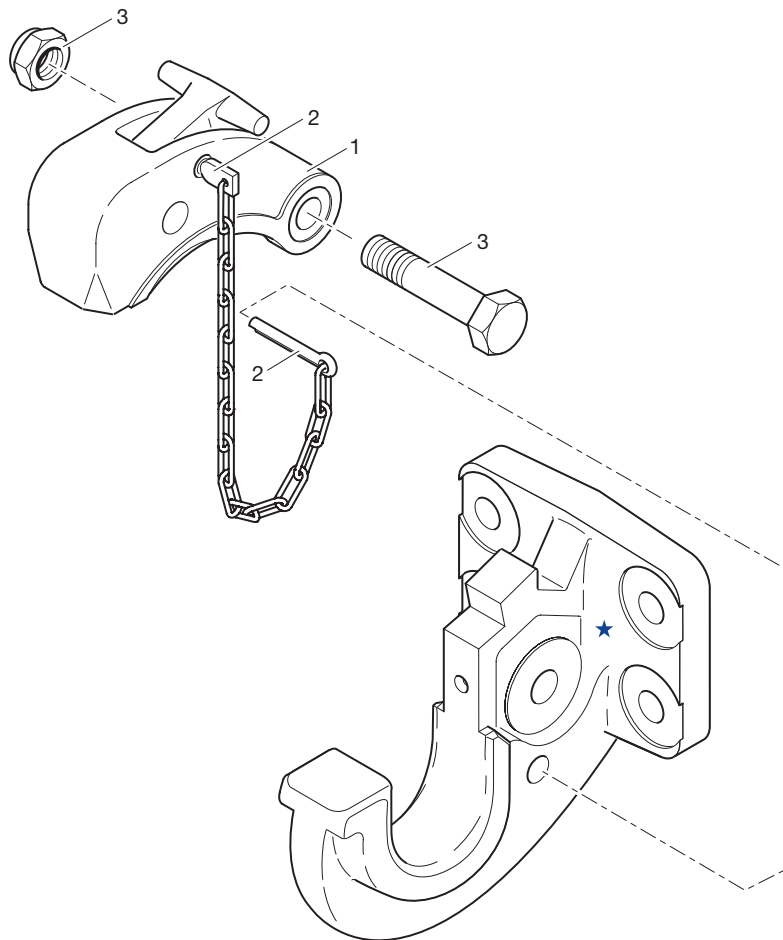

RO★231

Ersatzteile • Spare parts • Pièces de rechange • Ricambi • Piezas de recambio

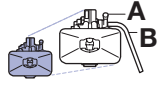

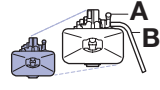

★ kein Ersatzteil
no spare part
non pièce de rechange
no ricambio
no es pieza de recambio

Pos		ROE	
01		ROE 70862	1
02		ROE 65112	1

Pos		ROE	
03		ROE 70863	1

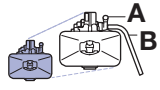
Befestigungssätze • Mounting kits • Kits de fixation • Kit di fissaggio • Conjuntos de fijación

Pos		ROE	
•	RO 231A050xx	ROE 70941	1
•	RO 231A0553	ROE 70949	1
•	RO 231A11000	ROE 70942	1
•	RO 231A1153	ROE 70923	1

RO★232 – 76 mm / 40 mm

- DE** Drehbare Hakenkupplung
- EN** Rotatable hook trailer hitch
- FR** Accouplement à crochet tournant
- IT** Gancio a uncino per motrici leggere
- ES** Enganche de gancho para furgonetas



a = 76 mm, VG 74059 NATO
 a = 40 mm, DIN 74054, 94/20/CE
 für Zugöse CH
 for towing eye CH
 pour anneau de remorquage CH
 per occhione di traino CH
 para punta de lanza CH

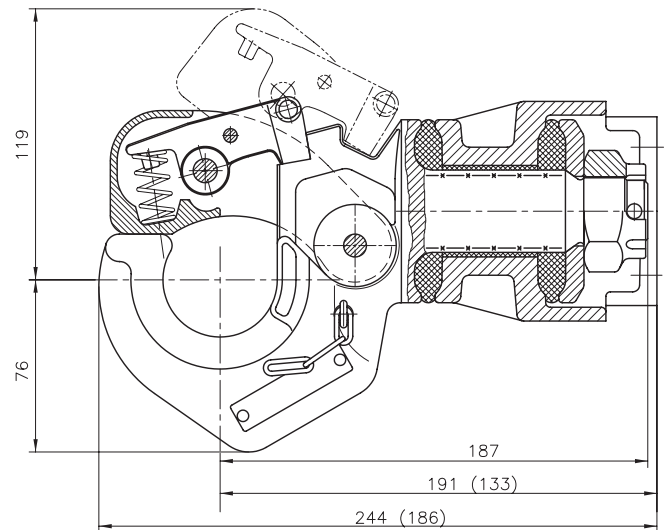
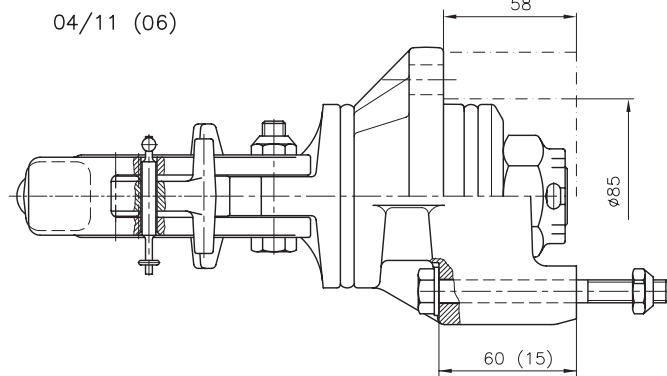

04/11 (06)

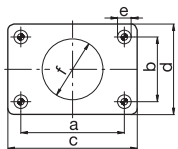

	a (mm)	b (mm)	c (mm)	d (mm)	e (mm)
04	85,0	45,0	112,0	96,0	13,0
11	83,0	56,0	112,0	96,0	10,5
06	101,6	101,6	130,0	130,0	13,0

Technische Daten • Technical data • Données technique • Dati tecnici • Datos técnicos



		(mm)					C (t)	(kg)	e1
			D (kN)	Dc (kN)	S (kg)	V (kN)			
RO 232A04531	04	85,0 x 45,0	40	22	300	14,2		7,0	
RO 232A04501	04	85,0 x 45,0	31	31	300		3,2	7,0	00-1350
RO 232A06001	06	101,6 x 101,6	40	22	300	14,2		6,7	
RO 232A06001	06	101,6 x 101,6	40	25	300	9,6		6,7	
RO 232A06531	06	101,6 x 101,6	40	22	300	14,2		6,7	
RO 232A11001	11	83,0 x 56,0	35	22	300	14,2		7,2	
RO 232A11531	11	83,0 x 56,0	35	20	250	12,0		7,2	
RO 232A11501	11	83,0 x 56,0	31	31	300		3,2	7,2	00-1353

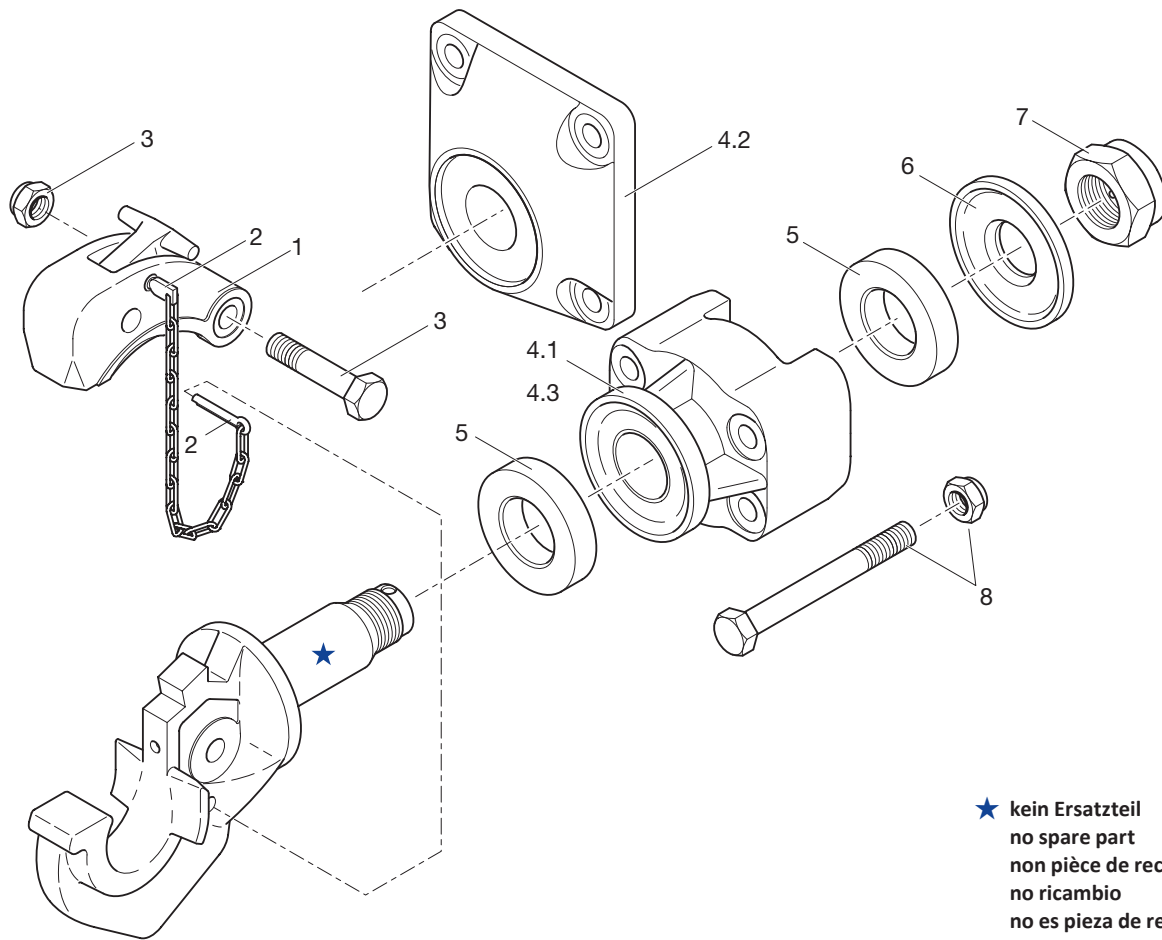

RO★232

Ersatzteile • Spare parts • Pièces de rechange • Ricambi • Piezas de recambio

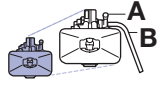

★ kein Ersatzteil
no spare part
non pièce de rechange
no ricambio
no es pieza de recambio

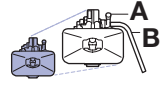
Pos		ROE	
01		ROE 70862	1
02		ROE 65112	1
03		ROE 70863	1
04.1	RO 232A04	ROE 70869	1
04.2	RO 232A06	ROE 70870	1
04.3	RO 232A11	ROE 70871	1
05		ROE 70864	1
06		ROE 59262	1

Pos		ROE	
07		ROE 56124	1
08	RO 232A0400x	ROE 70879	1
08	RO 232A0453x	ROE 70873	1
08	RO 232A0600x	ROE 70880	1
08	RO 232A0653x	ROE 70874	1
08	RO 232A1100x	ROE 70878	1
08	RO 232A1153x	ROE 70875	1

RO★240 – 40 mm

- DE** Drehbare Kupplung für Transporter
- EN** Rotable hitch for light trucks
- FR** Crochet d'attelage tournant pour véhicules utilitaires
- IT** Gancio girevole per motrici leggere
- ES** Enganche giratorio para furgonetas



a = 40 mm
DIN 74054
94/20/CE

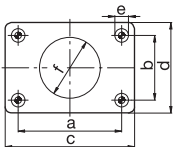
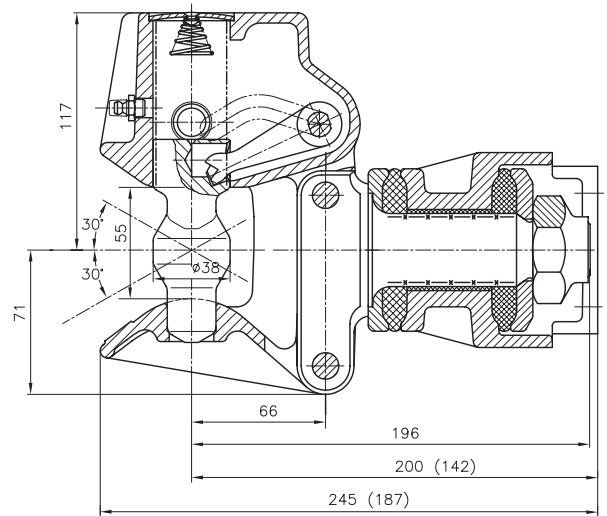
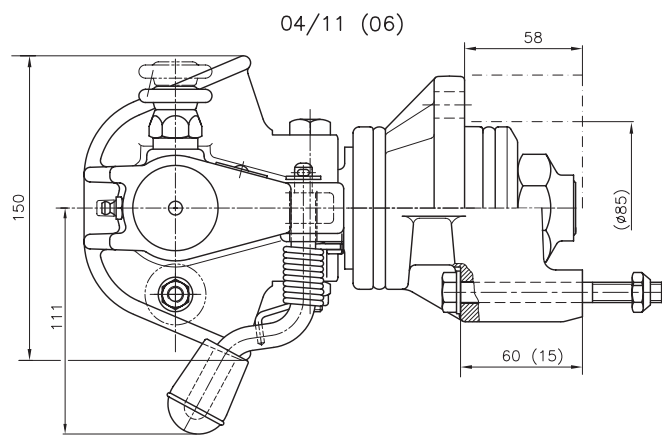

	a (mm)	b (mm)	c (mm)	d (mm)	e (mm)
04	85,0	45,0	112,0	96,0	13,0
06	101,6	101,6	130,0	130,0	13,0
11	83,0	56,0	112,0	96,0	10,5

Technische Daten • Technical data • Données technique • Dati tecnici • Datos técnicos



									e1
			(mm)	D (kN)	Dc (kN)	S (kg)	V (kN)	(kg)	
RO 240B04000	B	04	85,0 x 45,0	40	40	300	14,2	9,5	
RO 240B04530	B	04	85,0 x 45,0	40	22	300	14,2	9,5	
RO 240B06530	B	06	101,6 x 101,6	40	22	300	14,2	9,6	
RO 240B11000	B	11	83,0 x 56,0	35	35	250	12,0	9,4	00-0415
RO 240B11530	B	11	83,0 x 56,0	35	20	250	12,0	9,4	

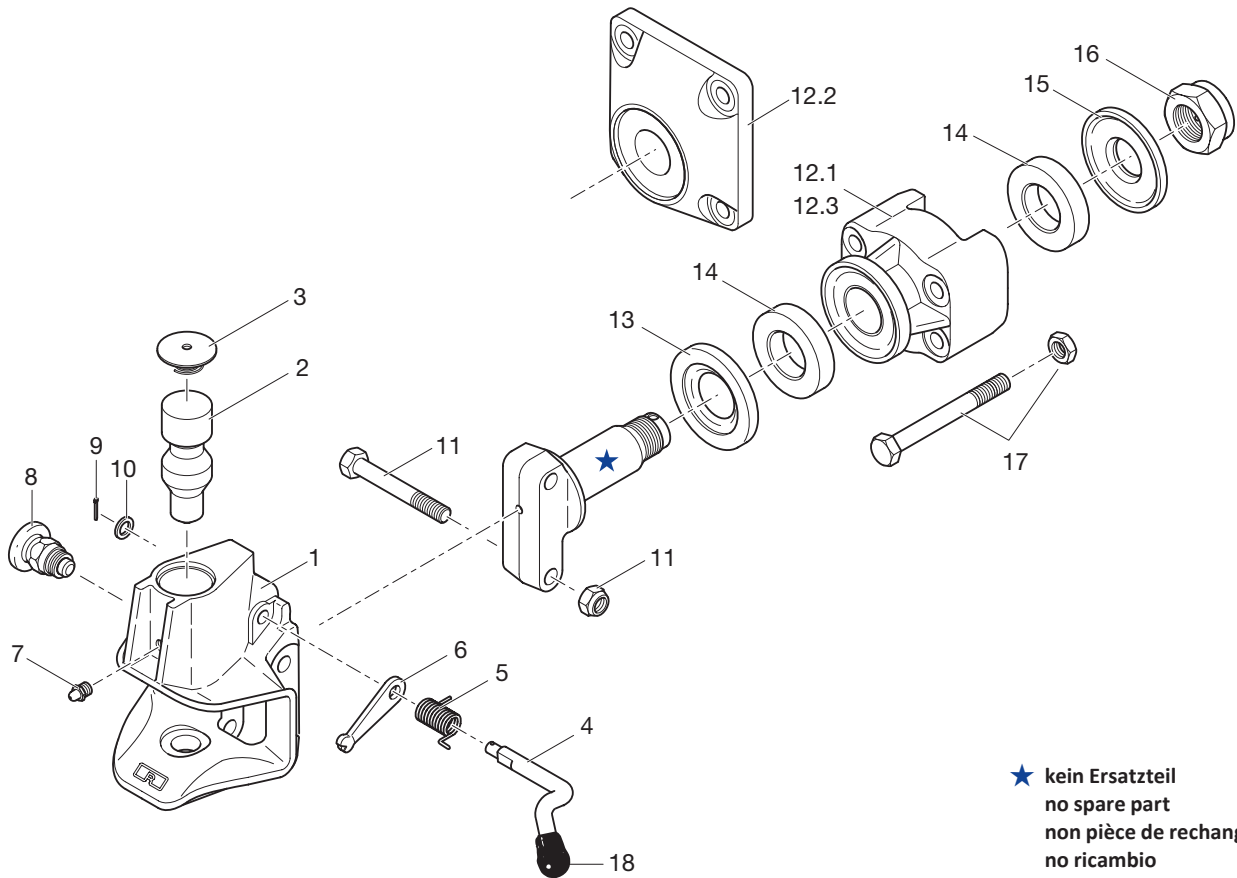

RO★240

Ersatzteile • Spare parts • Pièces de rechange • Ricambi • Piezas de recambio

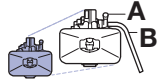

★ kein Ersatzteil
no spare part
non pièce de rechange
no ricambio
no es pieza de recambio

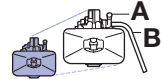
Pos		ROE	
01		ROE 71064	1
02		ROE 47026	1
03		ROE 67411	1
04		ROE 70867	1
06	Kit (04, 05, 06, 09, 10, 18)	ROE 70927	1
07		ROE 65018	1
08		ROE 70618	1
11		ROE 70868	1
12.1	85,0 x 45,0 mm	ROE 70869	1
12.2	101,6 x 101,6 mm	ROE 70870	1
12.3	83,0 x 56,0 mm	ROE 70871	1

Pos		ROE	
13		ROE 45131	1
14		ROE 70872	1
15		ROE 59262	1
16		ROE 56124	1
17	RO 240B04000	ROE 70879	1
17	RO 240B04530	ROE 70873	1
17	RO 240B06000	ROE 70880	1
17	RO 240B06530	ROE 70874	1
17	RO 240B11000	ROE 70878	1
17	RO 240B11530	ROE 70875	1
18		ROE 25106	1

RO*243 – 40 mm

- DE** Kompaktkupplung für Transporter, Lieferwagen, Geländewagen Fangmaulgröße 100 mm x 150 mm
- EN** Compact hitch for light trucks, delivery vans, cross country vehicles Funnel size 100 mm x 150 mm
- FR** Crochet d'attelage compact pour véhicules utilitaires, voitures de livraison, voitures tout terrain Dimension du pavillon 100 mm x 150 mm
- IT** Gancio compatto per motrici leggere, furgoni, fuoristrada Dimensioni testa campana 100 mm x 150 mm
- ES** Enganche compacto para furgonetas, camionetas, vehículos todo terreno Tamaño de boca de enganche 100 mm x 150 mm



a = 40 mm
DIN 74054 ECE (Class S)

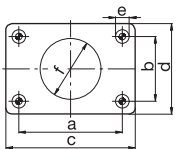
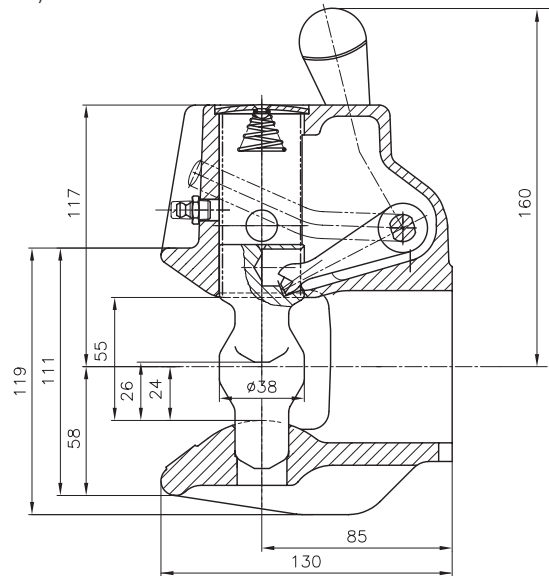
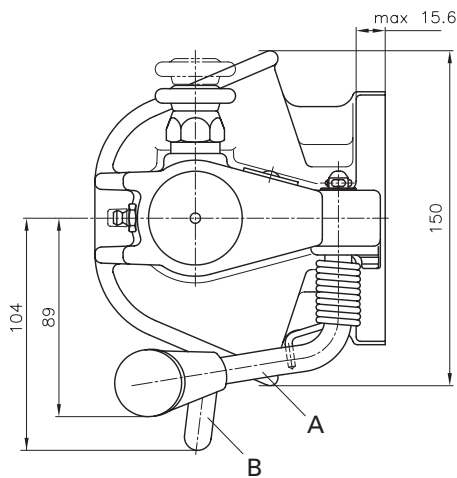

	a (mm)	b (mm)	c (mm)	d (mm)	e (mm)
11	83,0	56,0	110,0	85,0	10,5
12	85,0	45,0	110,0	85,0	10,5
35	120,0	55,0	155,0	90,0	15,0

Technische Daten • Technical data • Données technique • Dati tecnici • Datos técnicos



								ECE	
	A	B	(mm)	D (kN)	Dc (kN)	S (kg)	V (kN)	(kg)	
RO 243A11000	A	B	115	30	18	250	12,0	4,1	E1 55R-01 0031
RO 243A11000	A	B	115	30	30	250	8,4	4,1	E1 55R-01 0031
RO 243B11000	B	A	115	30	18	250	12,0	4,1	E1 55R-01 0031
RO 243B11000	B	A	115	30	30	250	8,4	4,1	E1 55R-01 0031
RO 243A12000	A	B	115	18	18	200	9,6	4,1	E1 55R-01 0031
RO 243B12000	B	A	115	18	18	200	9,6	4,1	E1 55R-01 0031
RO 243A35000	A	B	135	30	30	350	12,0	4,4	E1 55R-01 0051

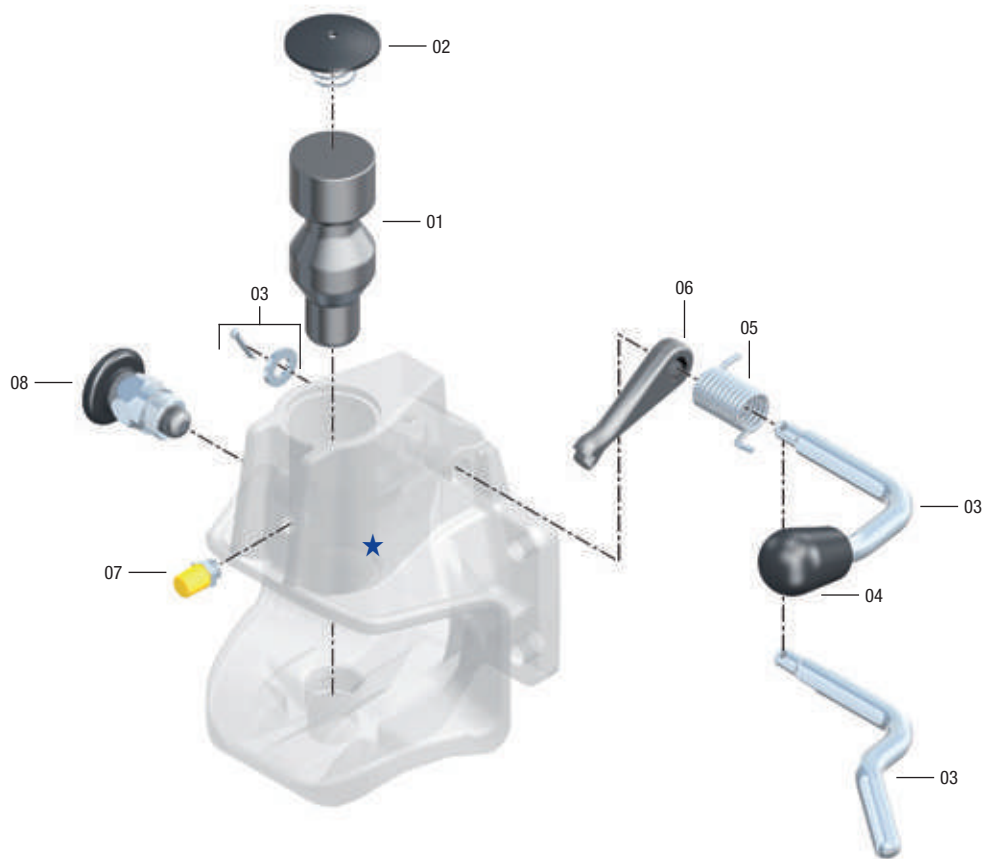

RO★243

Ersatzteile • Spare parts • Pièces de rechange • Ricambi • Piezas de recambio

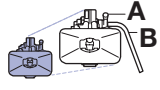

★ kein Ersatzteil
no spare part
non pièce de rechange
no ricambio
no es pieza de recambio

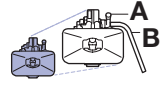
Pos		ROE	
01		ROE 47026	1
02		ROE 67411	1
03	RO xxxBxxxx	ROE 70354	1
03	RO xxxAxxxx	ROE 70355	1
03	RO xxxNxxxx	ROE 70353	1
04		ROE 25106	1

Pos		ROE	
06	Kit (03, 04, 05, 09, 10)	ROE 70927	1
07		ROE 65018	1
08		ROE 70618	1

RO★244-2

- DE** Kompaktkupplung für Flurförderzeuge und deren Anhänger
- EN** Compact hitch for industrial trucks and trailers
- FR** Crochet d'attelage compact pour chariots de manutention et leurs remorques
- IT** Gancio compatto per adibiti a movimentazione interna con relativi rimorchi
- ES** Enganche compacto para vehículos industriales y sus remolques

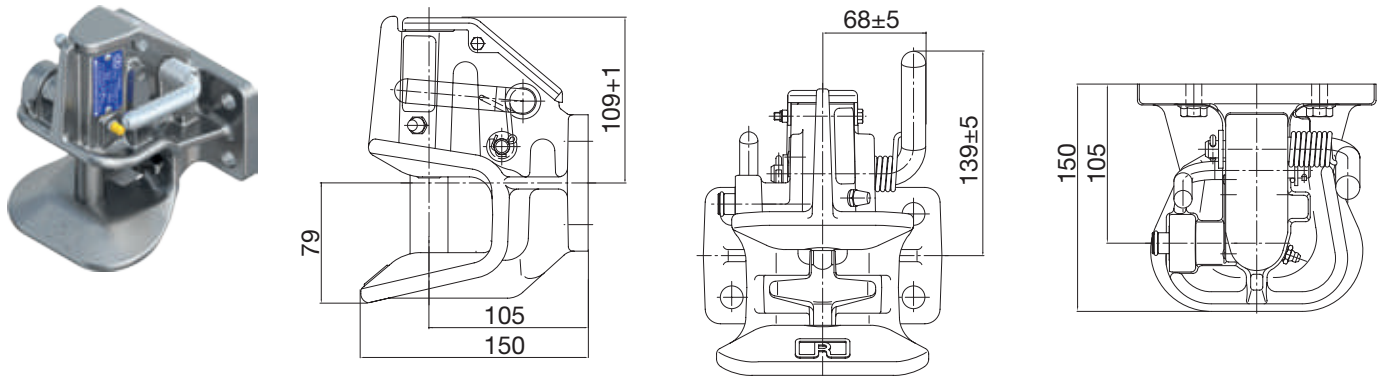

Für Zugöse, for drawbar eye, pour anneaux, per occhioni, para puntas:

1) DIN 74054*

2) DIN 8454

3) CUNA 438/40*

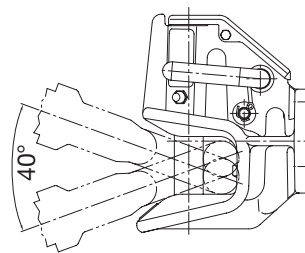
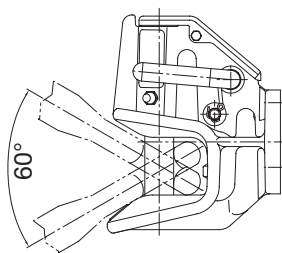
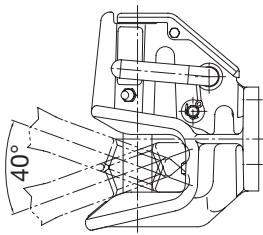

* nur auf nicht-öffentlichen Straßen • only on non-public roads • uniquement sur les routes non publiques • solo su strade non pubbliche • solo en vías no públicas

Technische Daten • Technical data • Données technique • Dati tecnici • Datos técnicos

									ECE
	A		(mm)	D (kN)	Dc (kN)	S (kg)	V (kN)	(kg)	
RO 244A07002	A	07	130 x 30	42	30	250	8,4	6	E1 55R-01 1803
RO 244A11002	A	115	83 x 56	42	30	250	8,4	6	E1 55R-01 1804
RO 244A35002	A	135	120 x 55	42	30	250	8,4	6	E1 55R-01 1802

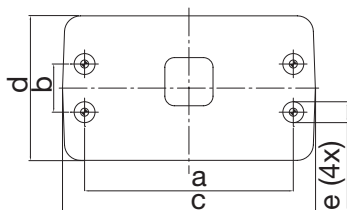

	a (mm)	b (mm)	c (mm)	d (mm)	e (mm)
07	130,0	30,0	155,0	90,0	13,0
115	83,0	56,0	155,0	90,0	10,5
135	120,0	55,0	155,0	90,0	15,0

RO★244-L

- DE** Kompaktkupplung für Flurförderzeuge und deren Anhänger mit Fußbetätigung
- EN** Compact hitch for industrial trucks and trailers with pedal release
- FR** Crochet d'attelage compact pour chariots de manutention et leurs remorques avec pédale
- IT** Gancio compatto per adibiti a movimentazione interna con relativi rimorchi con pedale
- ES** Enganche compacto para vehículos industriales y sus remolques mando per pedal

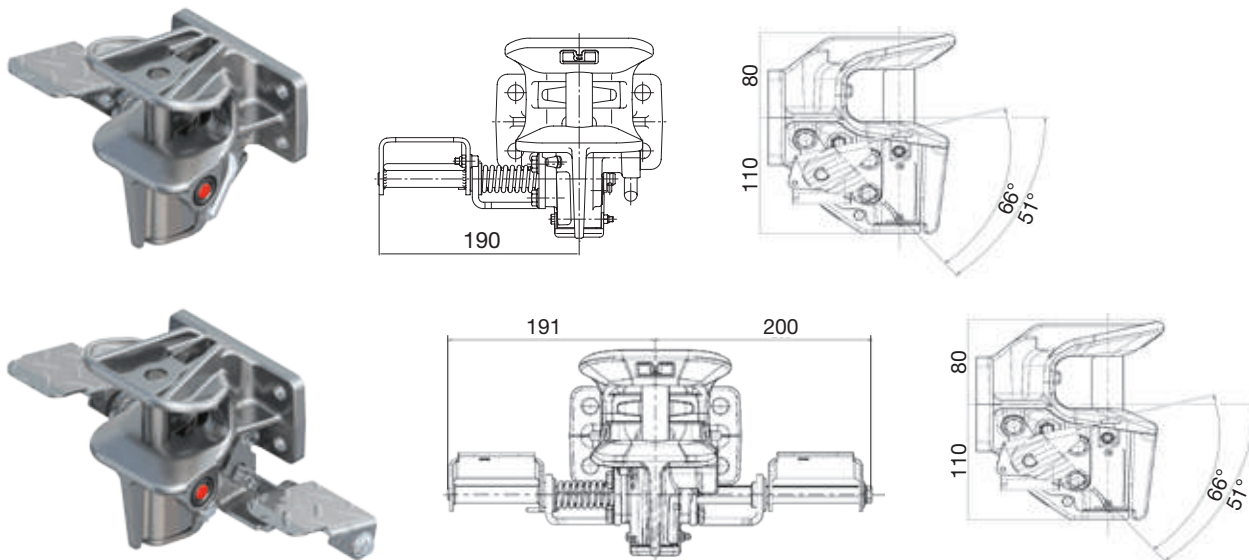





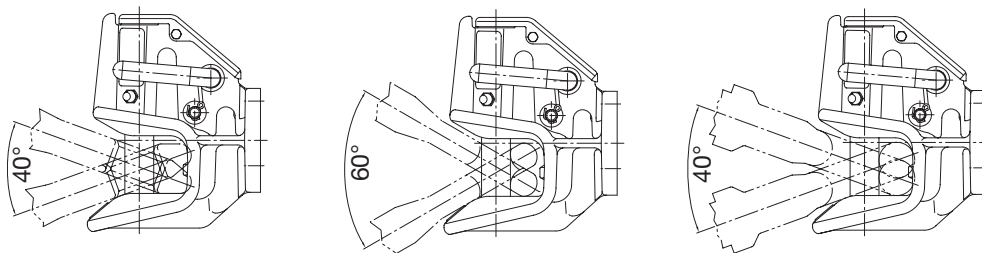

Für Zugöse, for drawbar eye, pour anneaux, per occhioni, para puntas:

- 1) DIN 74054*
- 2) DIN 8454
- 3) CUNA 438/40*



* nur auf nicht-öffentlichen Straßen • only on non-public roads • uniquement sur les routes non publiques • solo su strade non pubbliche • solo en vías no públicas

Technische Daten • Technical data • Données technique • Dati tecnici • Datos técnicos

	Klasse Class	 (mm)	 D (kN)	Dc (kN)	V (kN)	S (kg)	 (kg)				ECE
RO244L35002	S	120x55	42	30/18	8,4/12	250	7	X	X	-	E1 55R-01 1802
RO244L35502	S	120x55	42	30/18	8,4/12	250	8,2	-	-	X	E1 55R-01 1802

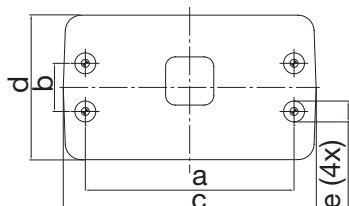

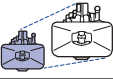

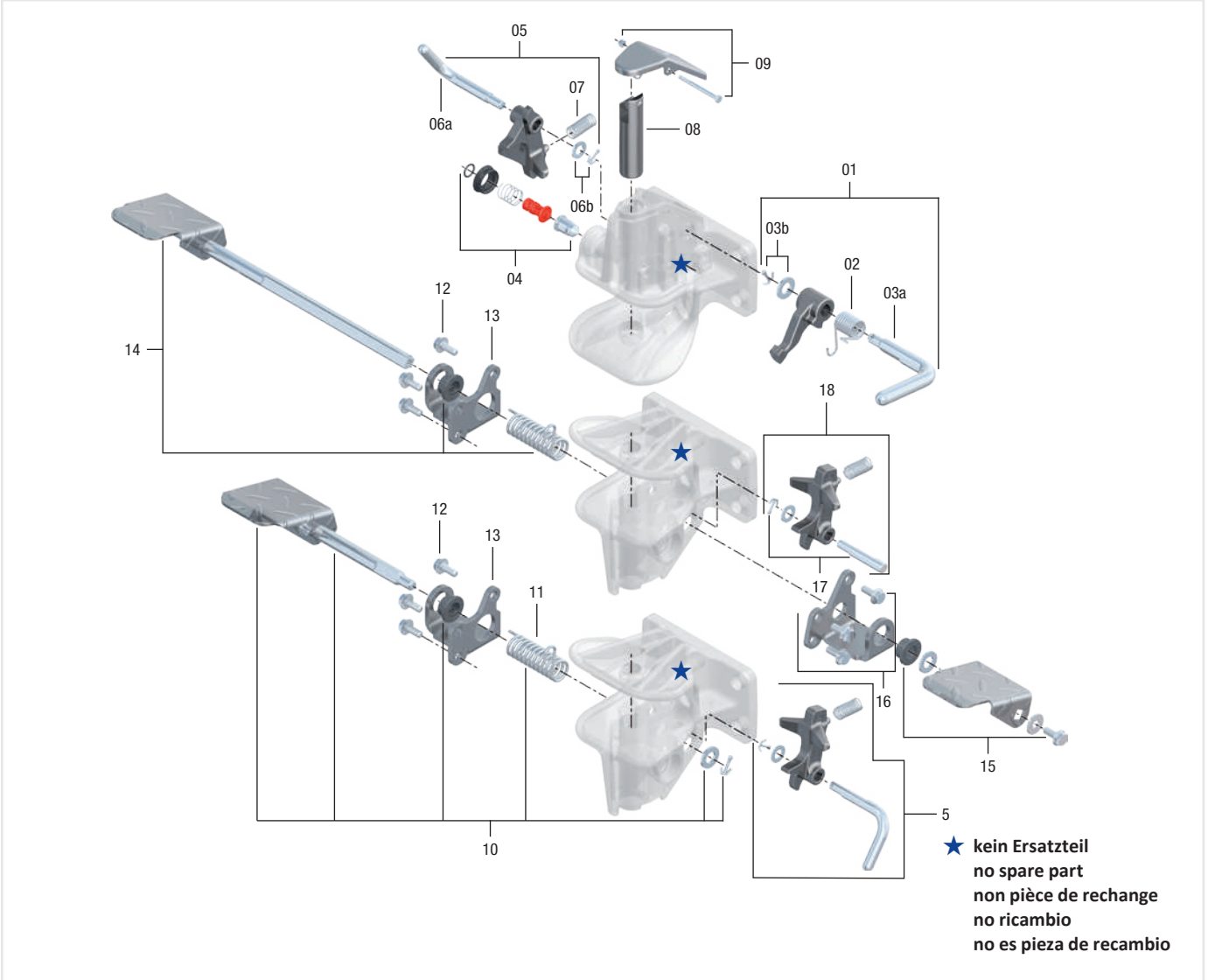

	a (mm)	b (mm)	c (mm)	d (mm)	e (mm)
07	130,0	30,0	158,0	90,0	13,0
115	83,0	56,0	158,0	90,0	10,5
135	120,0	55,0	158,0	90,0	15,0

RO★244-2

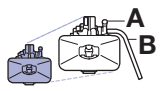
Ersatzteile • Spare parts • Pièces de rechange • Ricambi • Piezas de recambio

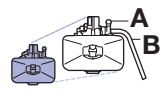

Pos		ROE	
1		ROE 71785	1
2		ROE 55205	1
3	3a + 3b	ROE 50209	1
4		ROE 71752	1
5		ROE 71786	1
6	6a + 6b	ROE 71788	1
7		ROE 55252	1
8		ROE 47137	1
9		ROE 71787	1
10	incl. 11 + 12	ROE 71789	1

Pos		ROE	
11		ROE 55289	1
12		ROE 71790	1
13		ROE 65791	1
14	incl. 15	ROE 71900	1
15		ROE 71901	1
16		ROE 71902	1
17		ROE 71903	1
18		ROE 71904	1

RO★245

- DE** Kompaktkupplung für innerbetrieblichen Transport
- EN** Compact hitch for internal transport
- FR** Crochet d'attelage compact pour le transport inter-usine ou sur parc
- IT** Gancio compatto per movimentazione interne
- ES** Enganche compacto para el transporte interno de la empresa



a = 40 mm DIN 74054
 a = 35 mm DIN 8454
 für Ringzugösen • for ring towing eye • pour anneau de remorquage • per occhione di traino • para punta de lanza anular:
 a = 40 mm ø 21 mm
 a = 56 mm ø 36 mm

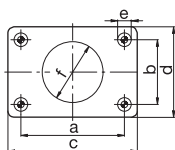
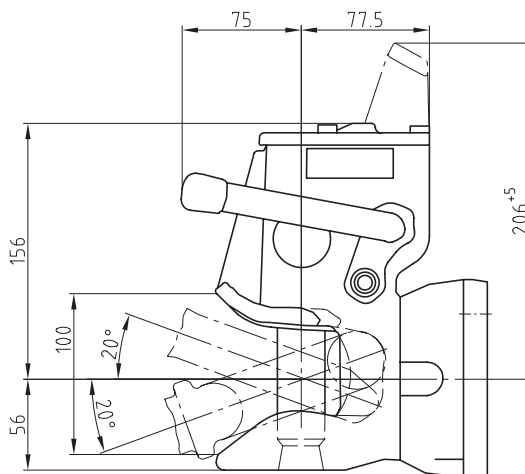
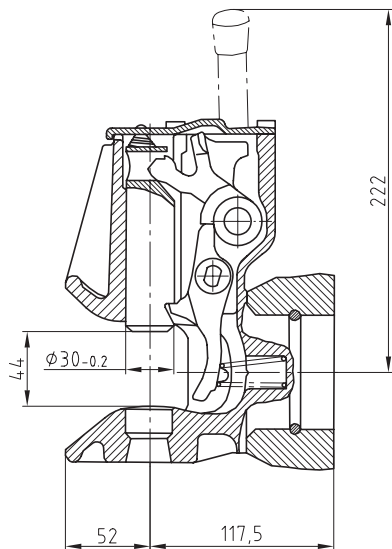
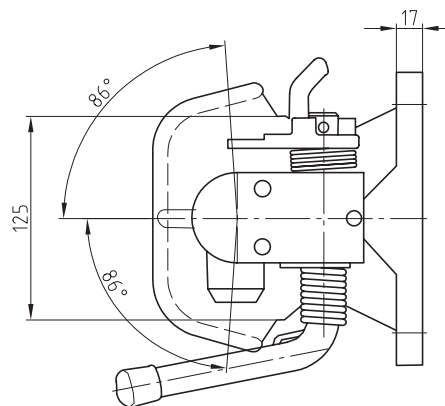

	a (mm)	b (mm)	c (mm)	d (mm)	e (mm)
145	140,0	80,0	182,0	122,0	17,0

Technische Daten • Technical data • Données technique • Dati tecnici • Datos técnicos



	A	B	C	D	D (kN)	(t)	S (kg)	C (t)	(kg)
RO 245A45020	A		145	140 x 80	73,6	7 x 3,5/4 x 10,5	350	3,0	12,6
RO 245A45500 ¹	A		145	140 x 80	73,6	7 x 3,5/4 x 10,5	350	3,0	12,6

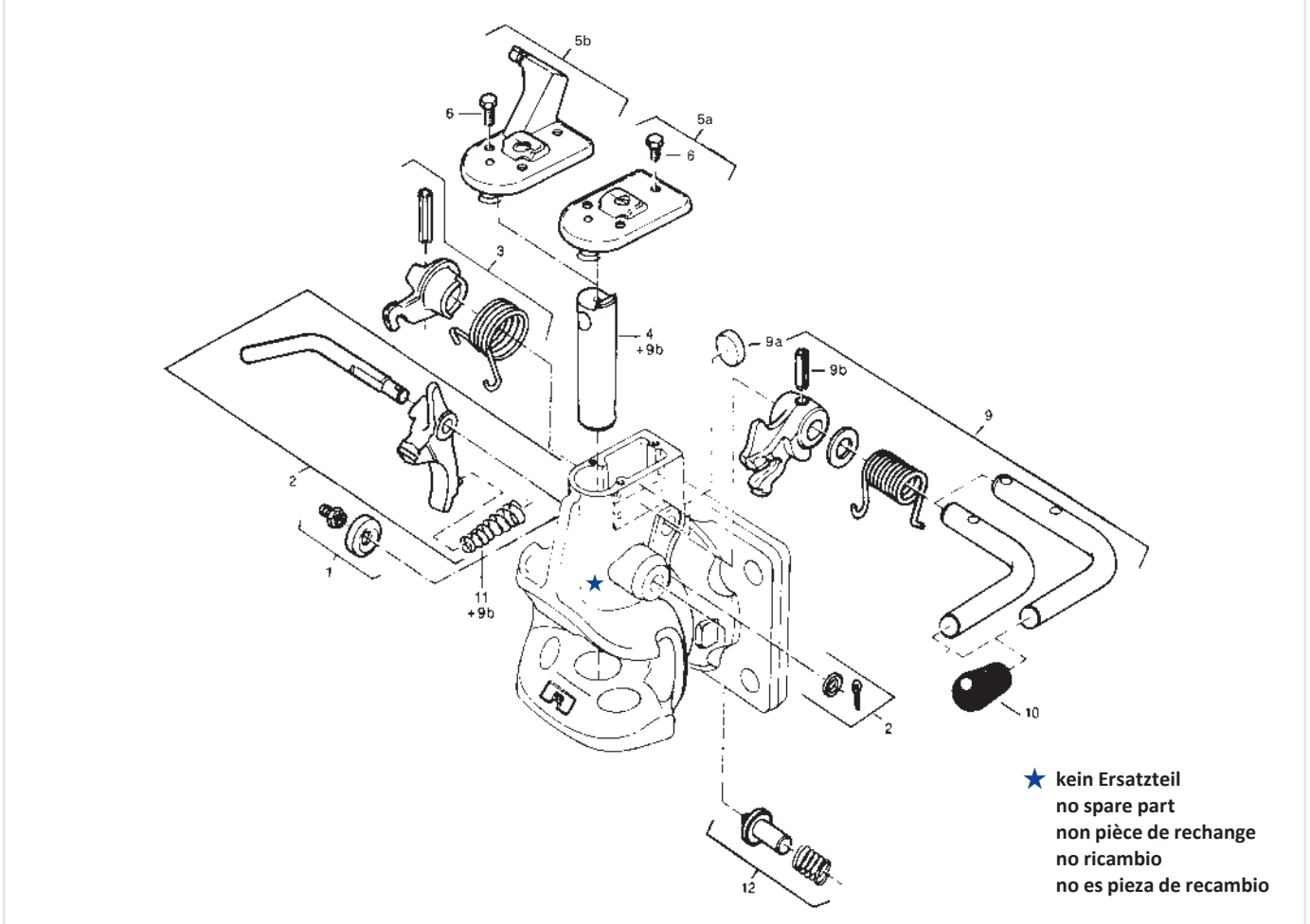

¹ für FB vorbereitet, prepared for FB, préparé pour FB, pronto per FB, preparado para FB (incl. ROE 70814)

RO★245

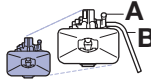
Ersatzteile • Spare parts • Pièces de rechange • Ricambi • Piezas de recambio

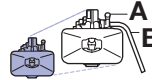

Pos		ROE	
01		ROE 67593	1
02	RO 245, A45, C, D	ROE 70332	1
04		ROE 47073	1
05a		ROE 65561	1
06		ROE 70248	1
09		ROE 70244	1

Pos		ROE	
10		ROE 25173	1
11		ROE 70247	1
12		ROE 70242	1

Sonderzubehör für Fernbetätigung • Special accessories for remote operation • Accessoires spéciaux pour commande à distance • Accessori speciali per telecomandi • Accesorios especiales para telemando



Pos	ROE		
02	ROE 70245		1
02	ROE 70246	RO 245 B	1
03	ROE 65562		1
05b	ROE 70814		1
09	ROE 70243		1
13	ROE 71164		1

Bowdenzug • Bowden cable • Câble Bowden • Tirante Bowden • Cable Bowden

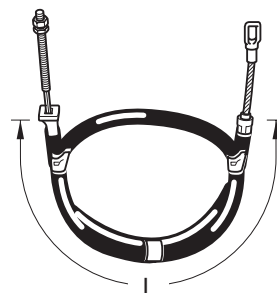

ROE	L
ROE 57337	850
ROE 57338	950
ROE 57339	1000
ROE 57340	1250
ROE 57341	1500
ROE 57342	1600
ROE 57343	2000
ROE 57344	2500
ROE 57345	3000
ROE 57346	4000
ROE 57347	5000
ROE 57348	7000

RO*253 – 40 mm

- DE** Drehbare Kupplung für Transporter
- EN** Rotable hitch for light trucks
- FR** Crochet d'attelage tournant pour véhicules utilitaires
- IT** Gancio girevole per motrici leggere
- ES** Enganche giratorio para furgonetas

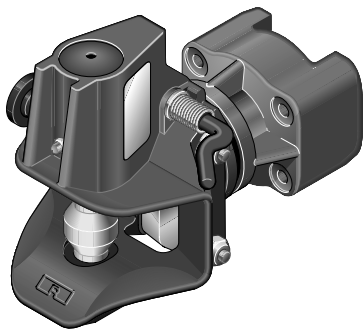

a = 40 mm
 DIN 74054, 94/20/CE
 für Zugöse CH
 for towing eye CH
 pour anneau de remorquage CH
 per occhione di traino CH
 para punta de lanza CH

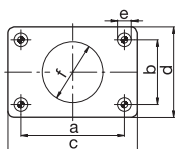
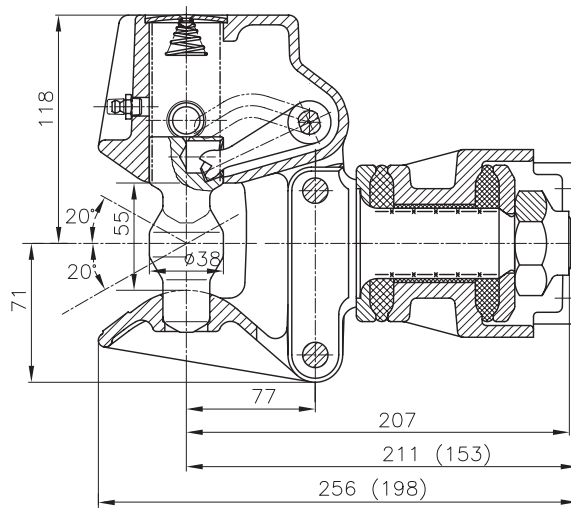
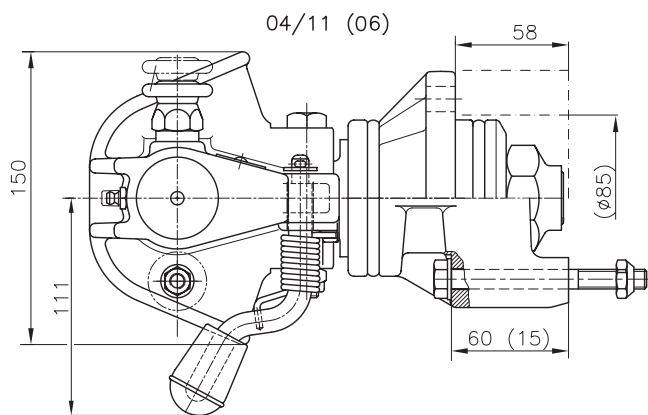

	a (mm)	b (mm)	c (mm)	d (mm)	e (mm)
04	85,0	45,0	112,0	96,0	13,0
06	101,6	101,6	130,0	130,0	13,0
11	83,0	56,0	112,0	96,0	10,0

Technische Daten • Technical data • Données technique • Dati tecnici • Datos técnicos

			(mm)	D (kN)	Dc (kN)	S (kg)	V (kN)	(kg)
RO 253B04000	B	04	85,0 x 45,0	40	40	300	14,2	9,8
RO 253B04530	B	04	85,0 x 45,0	40	22	300	14,2	9,8
RO 253B06530	B	06	101,6 x 101,6	40	22	300	14,2	10,0
RO 253B11000	B	11	83,0 x 56,0	35	35	250	12,0	9,4
RO 253B11530	B	11	83,0 x 56,0	35	20	250	12,0	9,4

RO★253

Ersatzteile • Spare parts • Pièces de rechange • Ricambi • Piezas de recambio

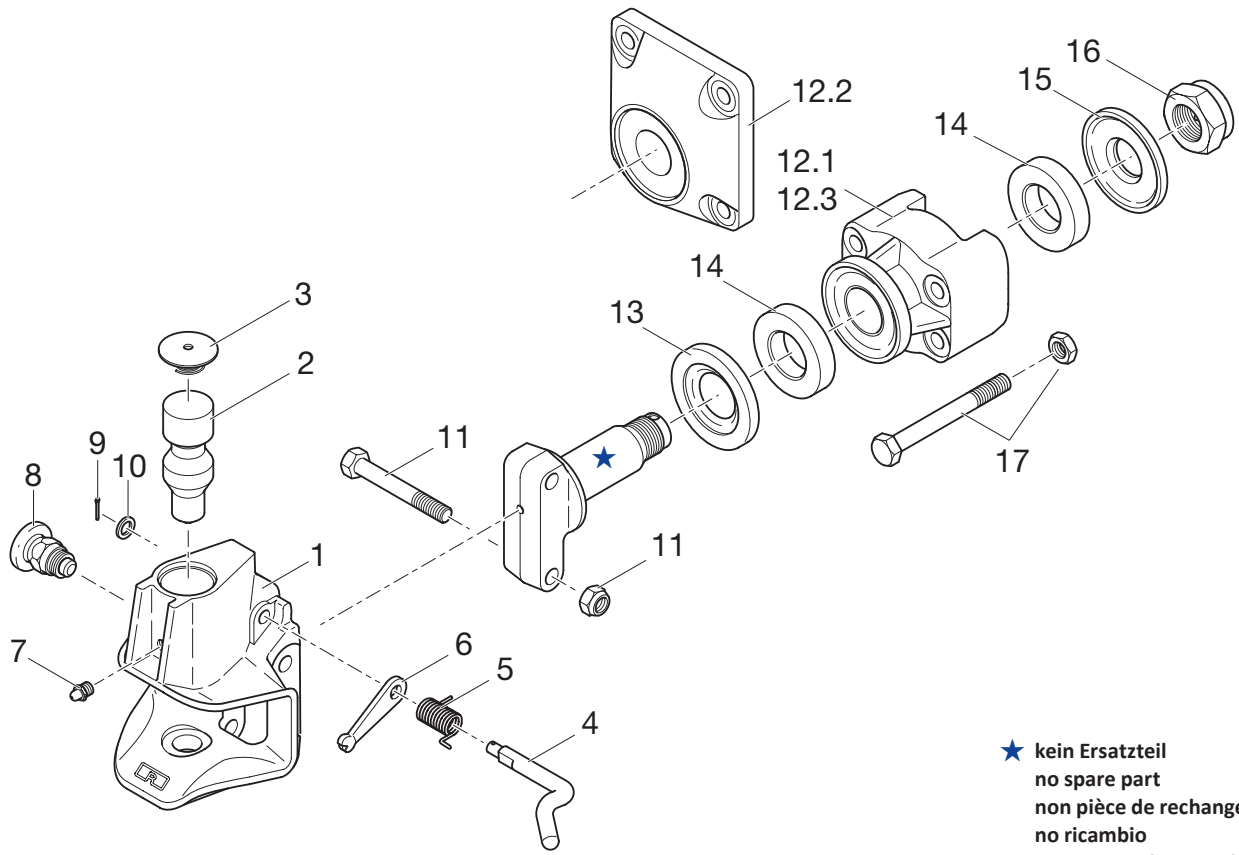

★ kein Ersatzteil
no spare part
non pièce de rechange
no ricambio
no es pieza de recambio

Pos		ROE	
01		ROE 71065	1
02		ROE 47097	1
03		ROE 67411	1
04		ROE 70867	1
06	Kit (04, 05, 06, 09, 10)	ROE 70926	1
07		ROE 65018	1
08		ROE 70618	1
11		ROE 70868	1
12.1	85,0 x 45,0 mm	ROE 70869	1
12.2	101,6 x 101,6 mm	ROE 70870	1
12.3	83,0 x 56,0 mm	ROE 70871	1

Pos		ROE	
13		ROE 45131	1
14	Kit	ROE 70872	1
15		ROE 59262	1
16		ROE 56124	1
17	RO 253B04000	ROE 70879	1
17	RO 253B04530	ROE 70873	1
17	RO 253B06000	ROE 70880	1
17	RO 253B06530	ROE 70874	1
17	RO 253B11000	ROE 70878	1
17	RO 253B11530	ROE 70875	1

RO★256 – 40 mm

- DE** Sonderkupplungen für Transporter
- EN** Special hitch for light trucks
- FR** Crochets d'attelage spéciaux pour véhicules utilitaires
- IT** Ganci speciali per motrici leggere
- ES** Enganches especiales para furgonetas



a = 40 mm
DIN 74054, ECE R55-01 (Class S)

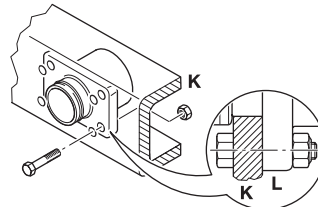
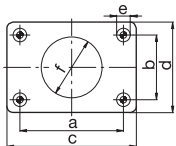
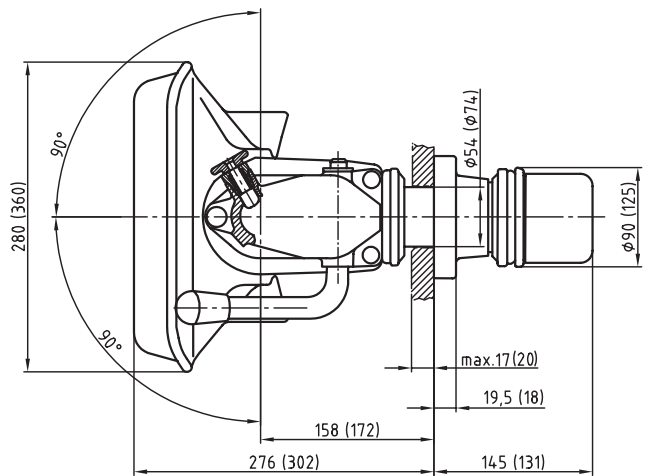
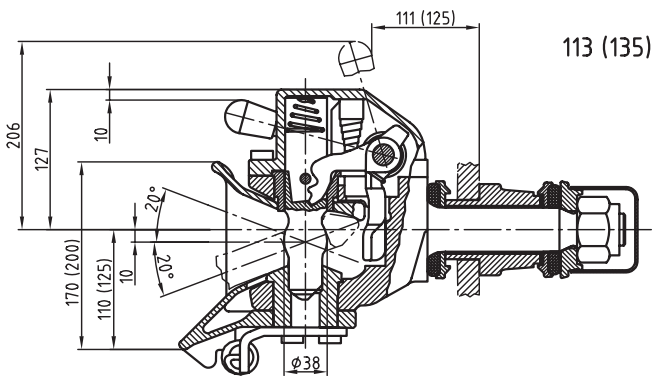

	a (mm)	b (mm)	c (mm)	d (mm)	e (mm)	f (mm)
113	83,0	56,0	110,0	85,0	10,5	55,0
135	120,0	55,0	155,0	90,0	15,0	74,0

	K (mm)	K (mm)
113	17	17
135	20	20



Technische Daten • Technical data • Données technique • Dati tecnici • Datos técnicos

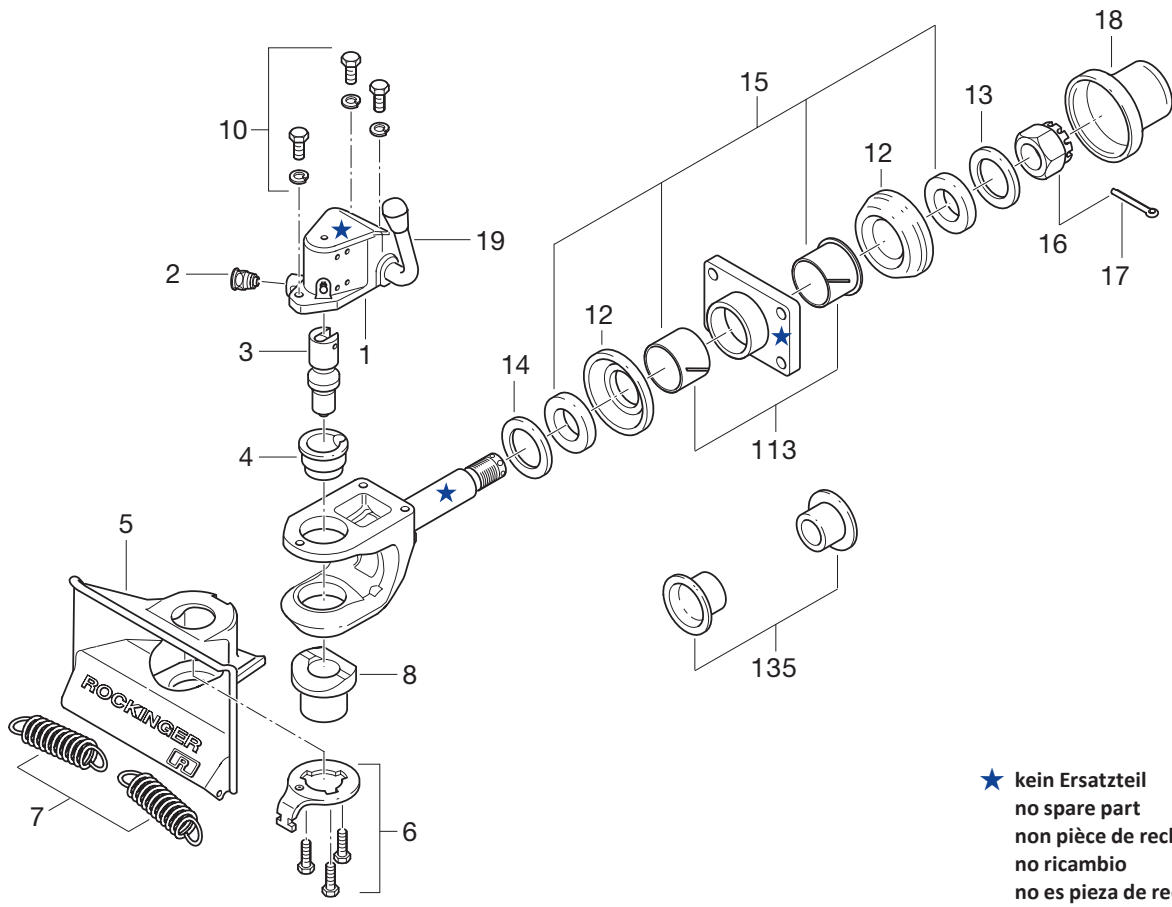

	C	D	A	B	D (kN)	Dc (kN)	S (kg)	V (kN)	(kg)	ECE
RO 256 A 11020	A	113	83 x 56	66	42,5	500	12,0	24	E1 55R-01 0432	
RO 256 B 11020	B	113	83 x 56	66	42,5	500	12,0	24	E1 55R-01 0432	
RO 256 A 35020	A	135	120 x 55	70	70,0	700	19,0	24	E1 55R-01 0453	
RO 256 B 35020	B	135	120 x 55	70	70,0	700	19,0	24	E1 55R-01 0453	

RO★256

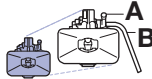
Ersatzteile • Spare parts • Pièces de rechange • Ricambi • Piezas de recambio

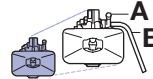

Pos		ROE	
01	RO xxxAxxxx, 113	ROE 66824	1
01	RO xxxAxxxx, 135	ROE 70581	1
01	RO xxxBxxxx, 113	ROE 66825	1
01	RO xxxBxxxx, 135	ROE 70580	1
02	113	ROE 70352	1
02	135	ROE 70599	1
03		ROE 47007	1
04		ROE 53041	1
05	113	ROE 46074	1
05	135	ROE 46105	1
06	113	ROE 70228	1
06	135	ROE 70726	1
07	113	ROE 55008	2
07	135	ROE 55005	2
08		ROE 53055	1
10	135	ROE 70727	1

Pos		ROE	
12	113	ROE 44087	1
12	135	ROE 44080	1
13	113	ROE 54938	1
13	135	ROE 54707	1
14	135	ROE 54460	1
15	113	ROE 67855	1
15	135	ROE 70343	1
16		ROE 56051	1
17		ROE 35031	1
18	113	ROE 25217	1
18	135	ROE 25076	1
19	RO xxxAxxxx	ROE 50070	1
19	RO xxxBxxxx	ROE 50064	1

RO★290 – 40 mm

- DE** Kupplung für schienengebundene Arbeitsmaschinen
- EN** Hitch for rail vehicles
- FR** Crochet pour machines-outils sur rails
- IT** Gancio per macchine di lavoro su rotaia
- ES** Enganche para máquinas de trabajo sobre carriles



a = 40 mm
DIN 74054

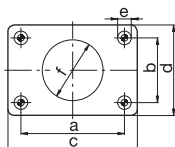
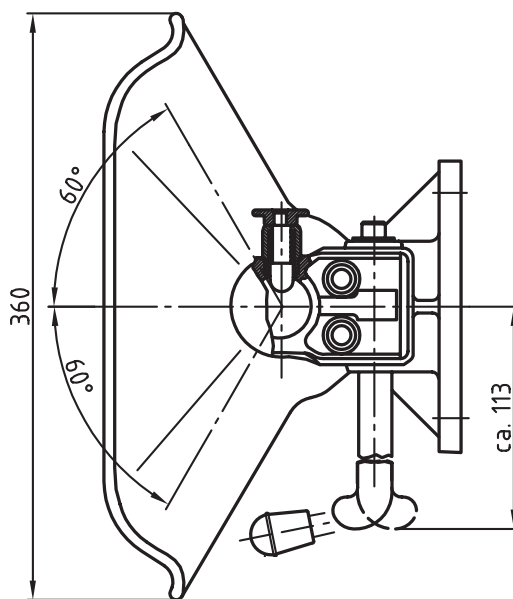
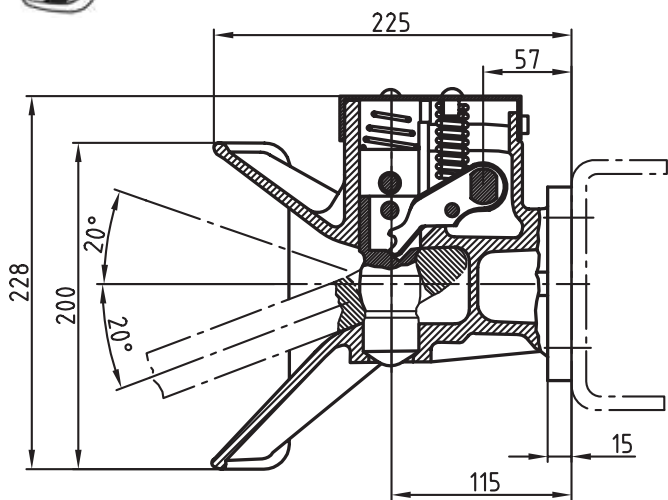

	a (mm)	b (mm)	c (mm)	d (mm)	e (mm)
145	140,0	80,0	180,0	120,0	17,0

Technische Daten • Technical data • Données technique • Dati tecnici • Datos técnicos



			(mm)	(t)	(kg)
RO 290A45020	B	145	140 x 80	14	15,4
RO 290A45520	A	145	140 x 80	14	15,4

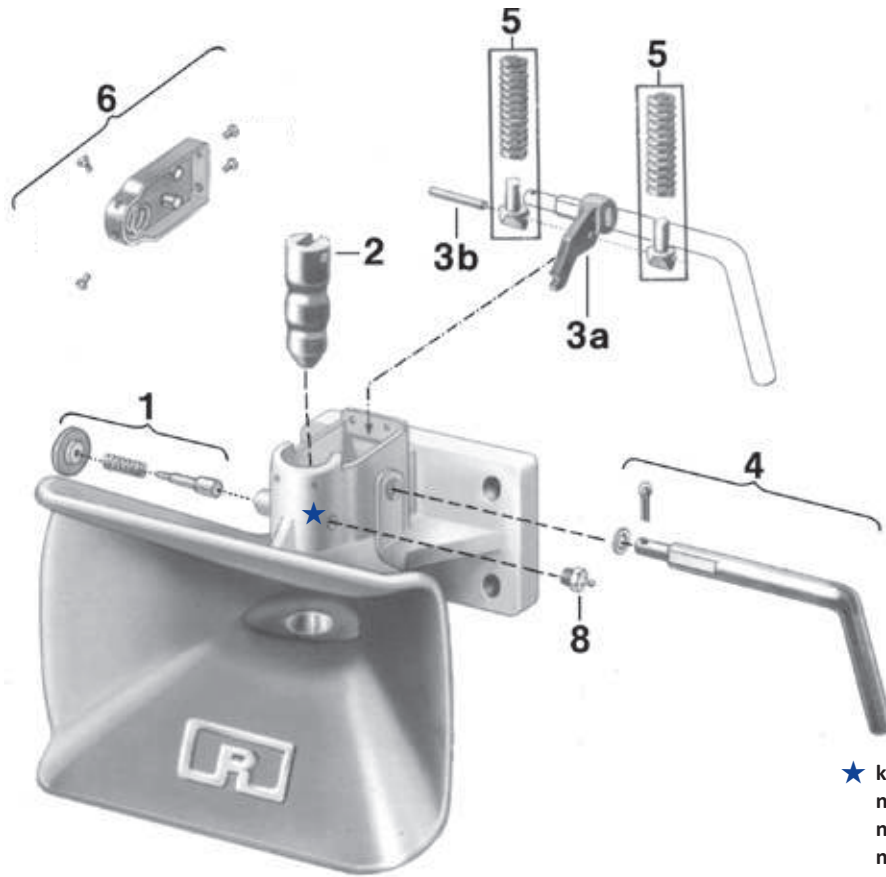

RO★290

Ersatzteile • Spare parts • Pièces de rechange • Ricambi • Piezas de recambio

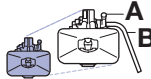

★ kein Ersatzteil
no spare part
non pièce de rechange
no ricambio
no es pieza de recambio

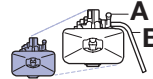
Pos		ROE	
01		ROE 70356	1
02		ROE 47005	1
03		ROE 51005	1
04	RO 290xx020	ROE 70296	1
04	RO 290xx520	ROE 50278	1

Pos		ROE	
05		ROE 70297	1
06		ROE 70298	1
08		ROE 65018	1

RO★40 E – 40 mm

- DE** Vollautomatische Anhängerkupplung
- EN** Fully automatic towing hitch
- FR** Crochet d'attelage entièrement automatique
- IT** Gancio di traino automatico
- ES** Enganche para remolque totalmente automático

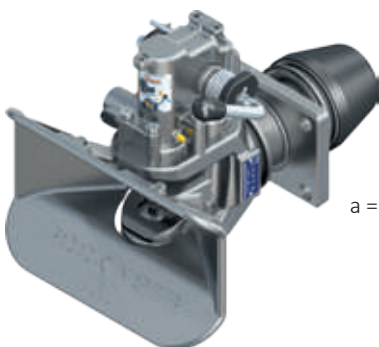

a = 40 mm
DIN 74054, ECE R55-01 (Class S)

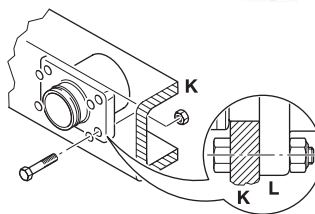
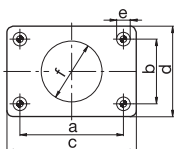
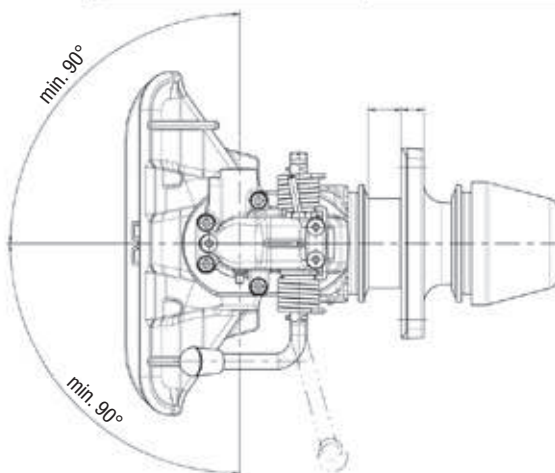
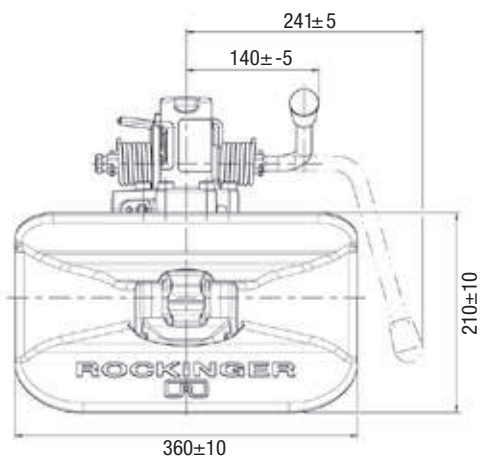
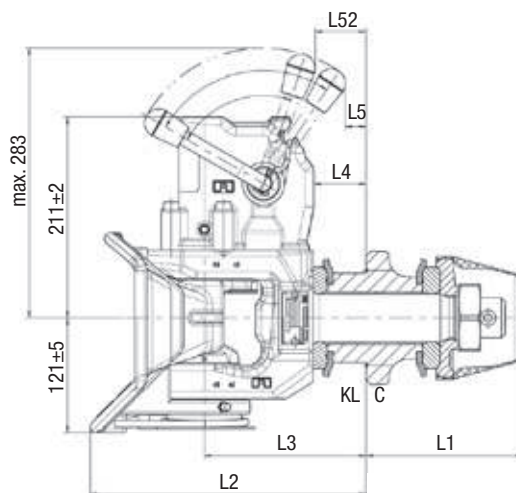

	a (mm)	b (mm)	c (mm)	d (mm)	e (mm)	f (mm)
135	120,0	55,0	155,0	90,0	15,0	74,0
145	140,0	80,0	180,0	120,0	17,0	84,0
150	160,0	100,0	200,0	140,0	21,0	94,0

	L1 (mm)	L2 (mm)	L3 (mm)	L4 (mm)	L5 (mm)	L52 (mm)	K (mm)	C (mm)	Lm (mm)
135	147,0	286,0	166,0	51,0	18,0	51	11,0-32,0	22,0	180,0
145	166,0	290,0	170,0	55,0	22,0	54	11,0-35,0	23,5	230,0
150	166,0	290,0	170,0	55,0	22,0	54	11,0-35,0	23,5	230,0

Technische Daten • Technical data • Données technique • Dati tecnici • Datos técnicos

		 (mm)	 D (kN) Dc (kN)		 S (kg) V (kN)		 (kg)	ECE		
			D (kN)	Dc (kN)	S (kg)	V (kN)				
RO 410A36021	135	120 x 55	70	70,0	700	24,0	30,0	E1 55R-01 1602		
RO 410B36021	135	120 x 55	70	70,0	500	26,4	30,0	E1 55R-01 1602		
RO 410A46021	145	140 x 80	100	90,5	1000	50,0	33,0	E1 55R-01 1601		
RO 410B46021	145	140 x 80	100	90,5	1000	50,0	33,0	E1 55R-01 1601		
RO 410A51021	150	160 x 100	168	90,5	1000	50,0	35,0	E1 55R-01 1600		
RO 410B51021	150	160 x 100	168	90,5	1000	50,0	35,0	E1 55R-01 1600		

RO★40 E

Ersatzteile • Spare parts • Pièces de rechange • Ricambi • Piezas de recambio

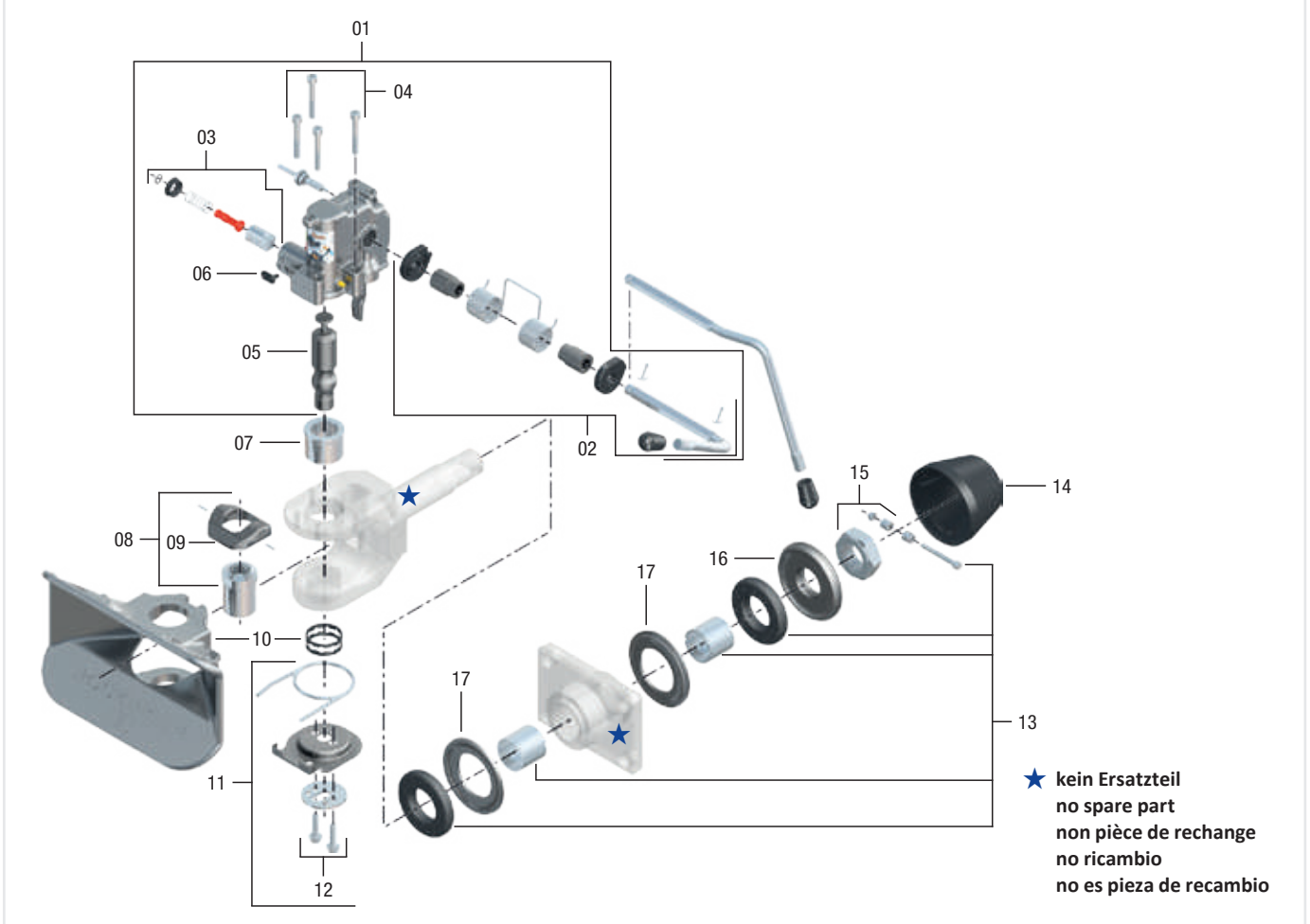

Pos		ROE		Pos		ROE	
1	A	ROE 71330A	1	11		ROE 71331	1
	B	ROE 71330B	1		12		ROE 30486
2	A	ROE 71644A	1	13	G135	ROE 71639	1
	B	ROE 71644B	1		G145/150	ROE 71640	1
3		ROE 71643	1	14	G135	ROE 25254	1
4		ROE 30396	1		G145/150	ROE 25347	1
5		ROE 47121	1	15	G135	ROE 71641	1
6		ROE 25558	1		G145/150	ROE 71642	1
7		ROE 53565	1	16	G145/150	ROE 12623	1
8		ROE 71692	1		G135	ROE 12636	1
9		ROE 59388	1	17	G135	ROE 44130	2
10		ROE 46128	1		G145/150	ROE 44134	2

RO★40 CH

- DE** Vollautomatische Anhängerkupplung
- EN** Fully automatic towing hitch
- FR** Crochet d'attelage entièrement automatique
- IT** Gancio di traino automatico
- ES** Enganche para remolque totalmente automático



a = 40 mm
DIN 74054, ECE R55-01 (Class S)
a = 40 mm
CH (z. B. ROE 57229)
a = 50 mm
DIN 74053, ECC R55-01 (Class D)

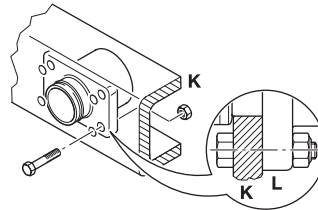
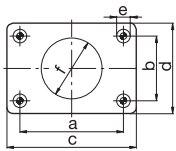
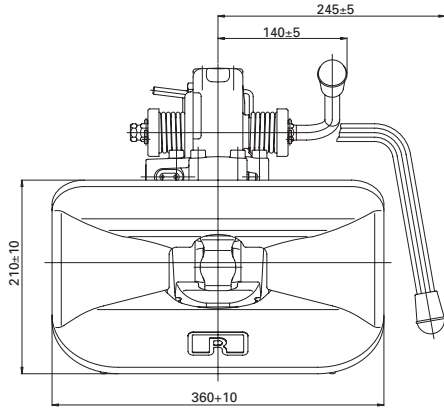
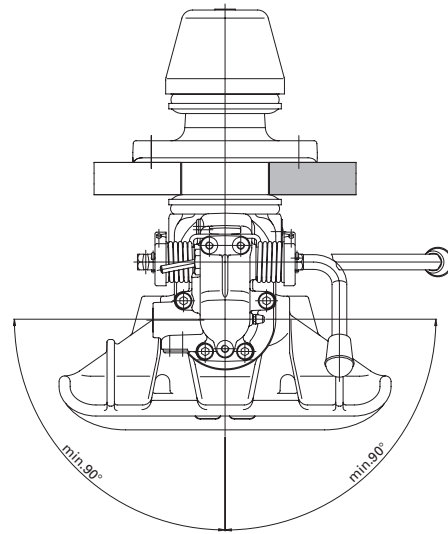
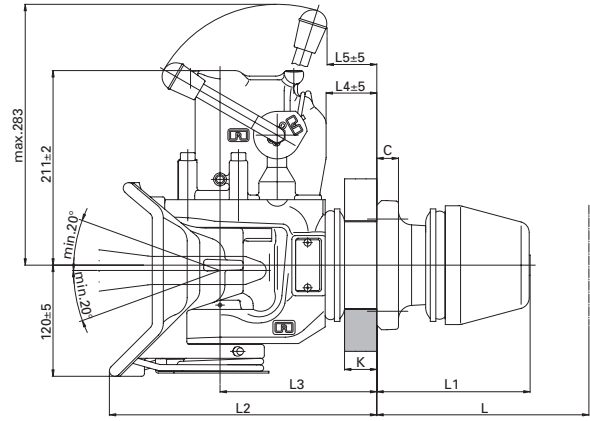

	a (mm)	b (mm)	c (mm)	d (mm)	e (mm)	f (mm)
135	120,0	55,0	155,0	90,0	15,0	74,0
145	140,0	80,0	180,0	120,0	17,0	84,0
150	160,0	100,0	200,0	140,0	21,0	94,0

	L1 (mm)	L2 (mm)	L3 (mm)	L4 (mm)	L5 (mm)	K (mm)	C (mm)	Lm (mm)
135	147,0	286,0	166,0	51,0	49,0	11,0-32,0	22,0	180,0
145	166,0	290,0	170,0	55,0	49,0	11,0-35,0	23,5	230,0
150	166,0	290,0	170,0	55,0	49,0	11,0-35,0	23,5	230,0



Technische Daten • Technical data • Données technique • Dati tecnici • Datos técnicos

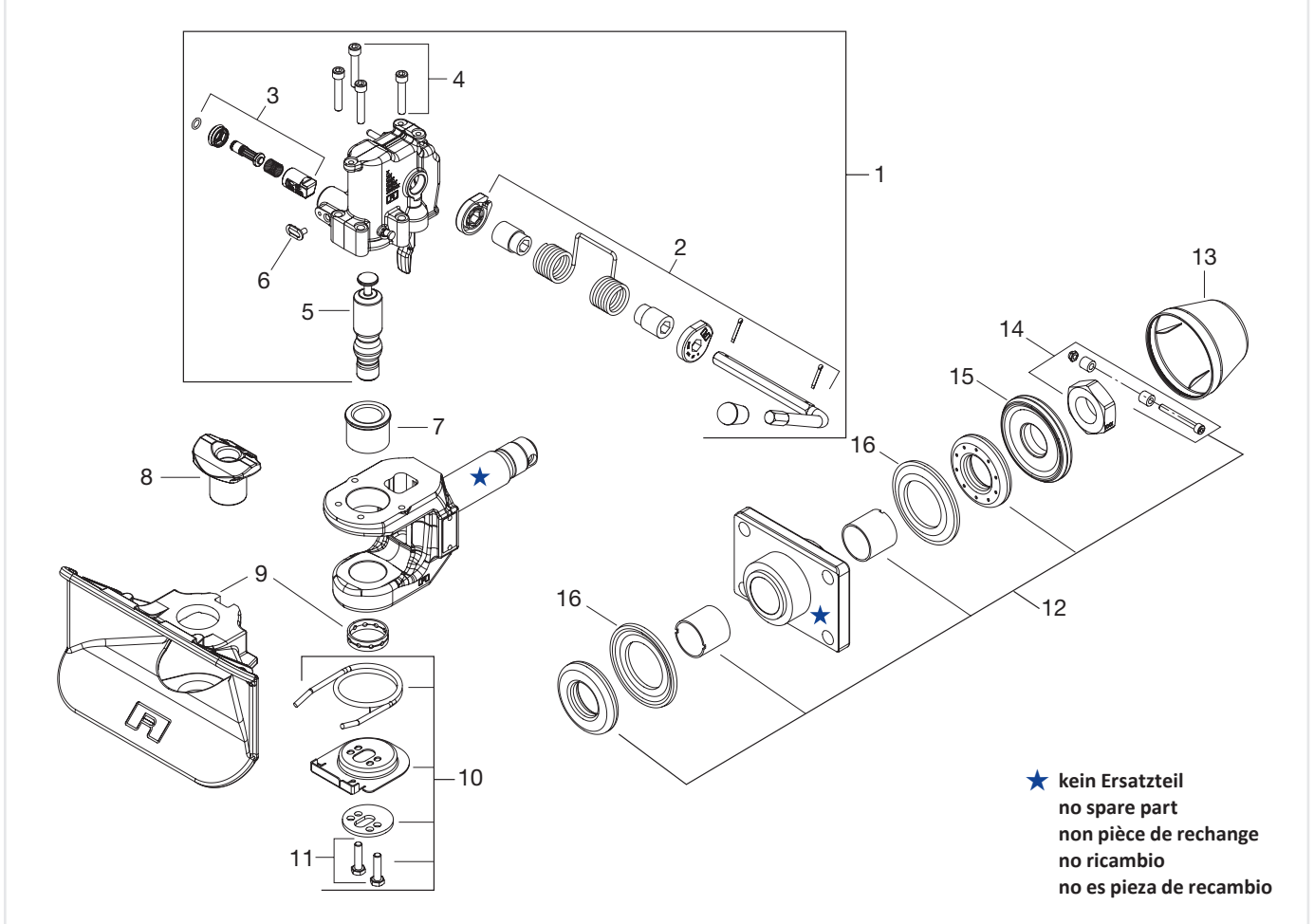

C D	A B		D (kN)	Dc (kN)	S (kg)	V (kN)	(kg)	ECE		
RO 413A	36501	135	120 x 55	70	70,0	700	24,0	30,0	E1 55R-01 1605	
RO 413B	36501	135	120 x 55	70	70,0	500	26,4	30,0	E1 55R-01 1605	
RO 413A	46501	145	140 x 80	100	91,5	1000	36,0	33,0	E1 55R-01 1604	
RO 413B	46501	145	140 x 80	100	91,5	1000	36,0	33,0	E1 55R-01 1604	
RO 413A	51501	150	160 x 100	168	91,5	1000	36,0	35,0	E1 55R-01 1603	
RO 413B	51501	150	160 x 100	168	91,5	1000	36,0	35,0	E1 55R-01 1603	

RO*40 CH

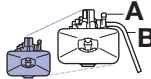
Ersatzteile • Spare parts • Pièces de rechange • Ricambi • Piezas de recambio

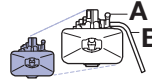

Pos		ROE	
01	A	ROE 71330A	1
	B	ROE 71330B	1
02	A	ROE 71644A	1
	B	ROE 71644B	1
03		ROE 71643	1
04		ROE 30396	1
05		ROE 47121	1
06		ROE 25558	1
07		ROE 53565	1
08		ROE 53566	1
09		ROE 46129	1
10		ROE 71331	1

Pos		ROE	
11		ROE 30486	1
		ROE 71639	1
12	G135	ROE 71640	1
	G145/G150	ROE 25254	1
13	G135	ROE 25347	1
	G145/G150	ROE 71641	1
14	G135	ROE 71642	1
	RO 413A/Bxx500	ROE 71796	1
15	RO 413A/Bxx501	ROE 12623	1
	G145/G150	ROE 12636	1
16	G135	ROE 44130	2
	G145/G150	ROE 44134	2

RO★400-1

- DE** Standardkupplung
- EN** Standard hitch
- FR** Crochet standard
- IT** Gancio di traino standard
- ES** Enganche estándar



a = 40 mm
DIN 74054, ECE R55-01 (Class S)

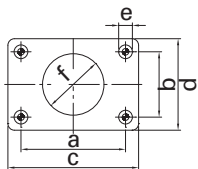
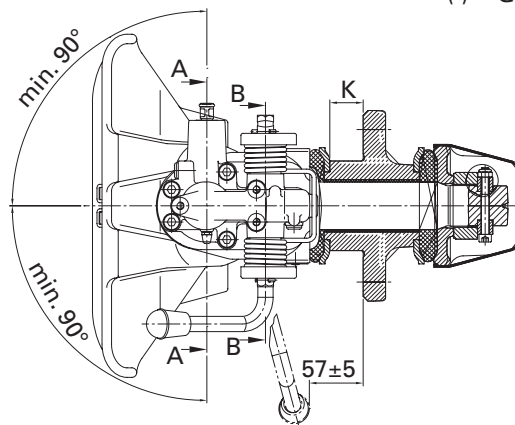
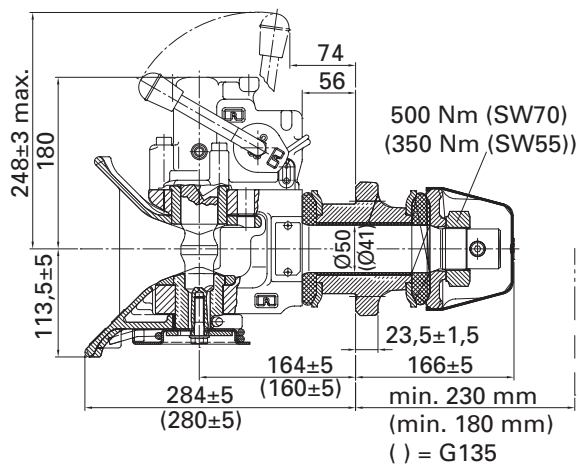
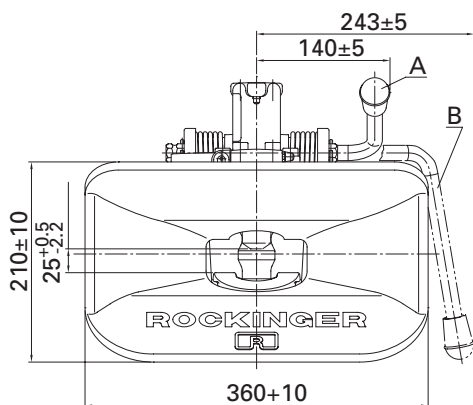

	a (mm)	b (mm)	c (mm)	d (mm)	e (mm)	f (mm)
135	120,0	55,0	155,0	90,0	15,0	74,0
145	140,0	80,0	180,0	120,0	17,0	84,0
150	160,0	100,0	200,0	140,0	21,0	94,0

	K (mm)	K (mm)
135	11-32	max. 32
145	11-35	max. 35
150	11-35	max. 35

Technische Daten • Technical data • Données technique • Dati tecnici • Datos técnicos



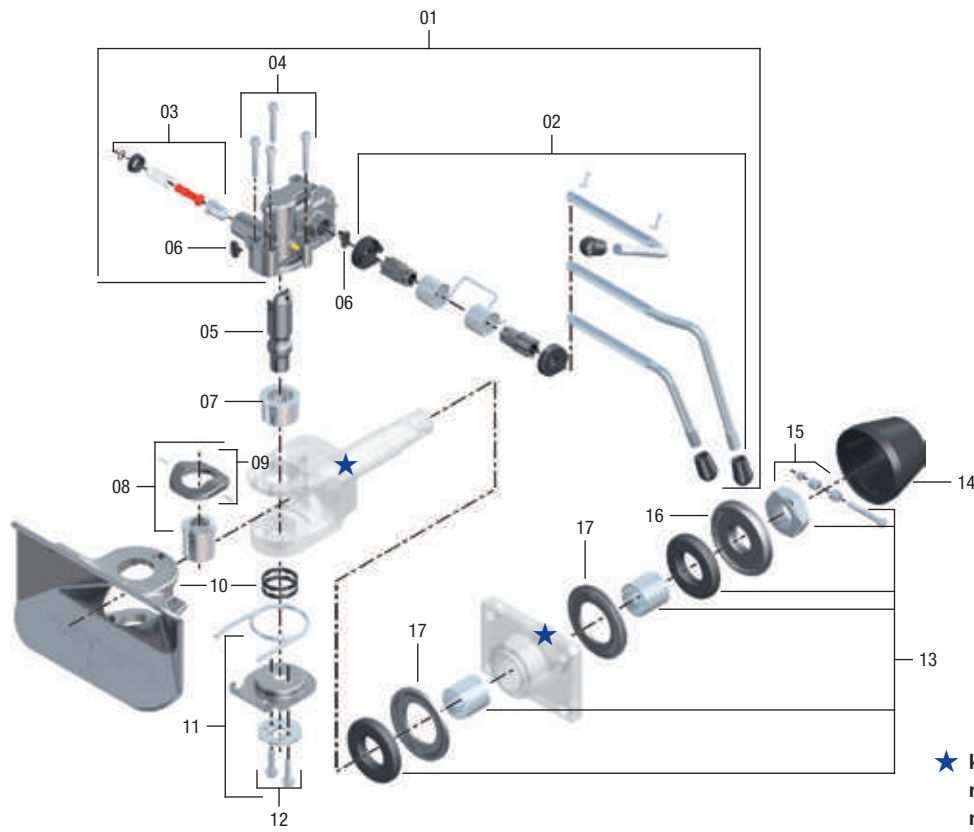

C D A B	D	(mm)	Truck		S (kg)	V (kN)	(kg)	ECE	ROE
			D (kN)	Dc (kN)					
RO 400A36001	135	120 x 55	88,3	70,0	700	24,0	30,0	E1 55R-01 0352	70970
RO 400A36001	135	120 x 55	88,3	70,0	500	26,4	30,0	E1 55R-01 0352	70970
RO 400B36001	135	120 x 55	88,3	70,0	700	24,0	30,0	E1 55R-01 0352	70970
RO 400B36001	135	120 x 55	88,3	70,0	500	26,4	30,0	E1 55R-01 0352	70970
RO 400A46001	145	140 x 80	100	91,5	1000	31,2	33,0	E1 55R-01 0351	70952
RO 400B46001	145	140 x 80	100	91,5	1000	31,2	33,0	E1 55R-01 0351	70952
RO 400A51001	150	160 x 100	130	90,0	1000	35,0	35,0	E1 55R-01 0350	70971
RO 400B51001	150	160 x 100	130	90,0	1000	35,0	35,0	E1 55R-01 0350	70971
RO 400A51201	150	160 x 100	130	90,0	1000	35,0	35,0	E1 55R-01 0350	x 70971

RO★400-1

Ersatzteile • Spare parts • Pièces de rechange • Ricambi • Piezas de recambio

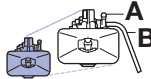

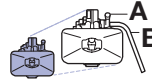
★ kein Ersatzteil
no spare part
non pièce de rechange
no ricambio
no es pieza de recambio

Pos		ROE		Pos		ROE	
01	A	ROE 71448A	1	10		ROE 46109	1
	B	ROE 71448B	1	11		ROE 71331	1
	B 400BXX501	ROE 71835B	1	12		ROE 30486	1
02	A	ROE 71795A	1	13	G135	ROE 71639	1
	B	ROE 71795B	1		G145/150	ROE 71640	1
	B 400BXX501	ROE 71795B1	1	14	G135	ROE 25254	1
03		ROE 71491	1		G145/150	ROE 25347	1
04		ROE 30361	1	15	G135	ROE 71641	1
05		ROE 47099	1		G145/150	ROE 71796	1
06		ROE 25558	1	16	G145/150	ROE 59280	1
07		ROE 53520	1		G135	ROE 59279	1
08		ROE 71718	1	17	G135	ROE 44160	1
09		ROE 59415	1		G145/150	ROE 44161	1

Reparatursatz • Repair kit • Kit de réparation • Kit riparazione • Juego de reperation

Pos	ROE
03, 05, 07, 08, 11	ROE 71728

RO★430 – 40 mm

- DE** Komfortkupplung. Spielfrei, gefedert, gedämpft
- EN** Comfort hitch. Slack-free, with buffers, dampened
- FR** Crochet d'attelage confort. Sans jeu, à ressorts, amorti
- IT** Gancio comfort. Senza gioco, molleggiato, ammortizzato
- ES** Enganche confort. Exento de juego, con almohadillas, amortiguado

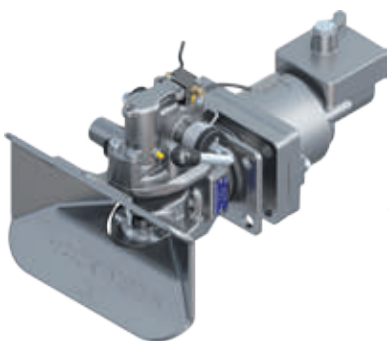

a = 40 mm
DIN 74054, ECE R55-01 (Class S)

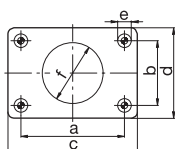
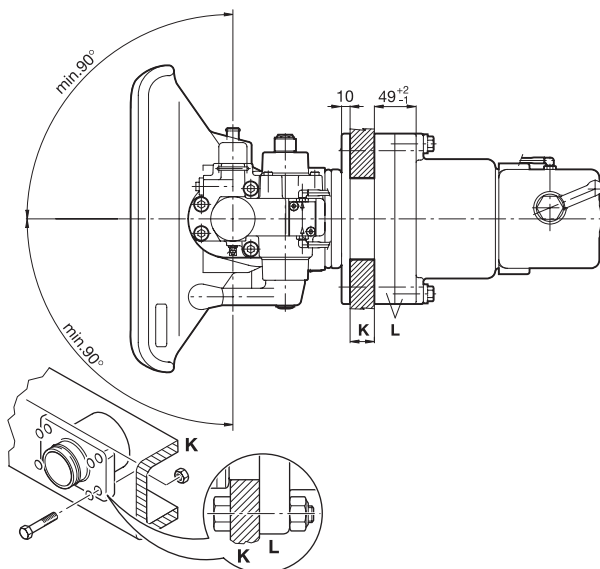
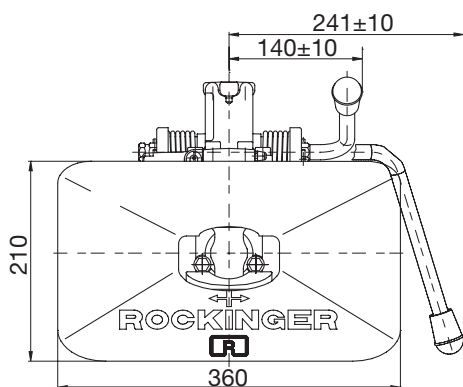
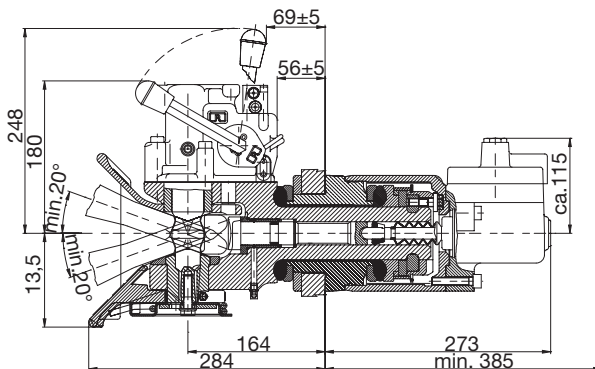

	a (mm)	b (mm)	c (mm)	d (mm)	e (mm)	f (mm)
145	140,0	80,0	180,0	120,0	17,0	84,0
150	160,0	100,0	200,0	140,0	21,0	94,0

	K (mm)	K (mm)
145	11-28	max. 28
150	11-28	max. 28

Technische Daten • Technical data • Données technique • Dati tecnici • Datos técnicos



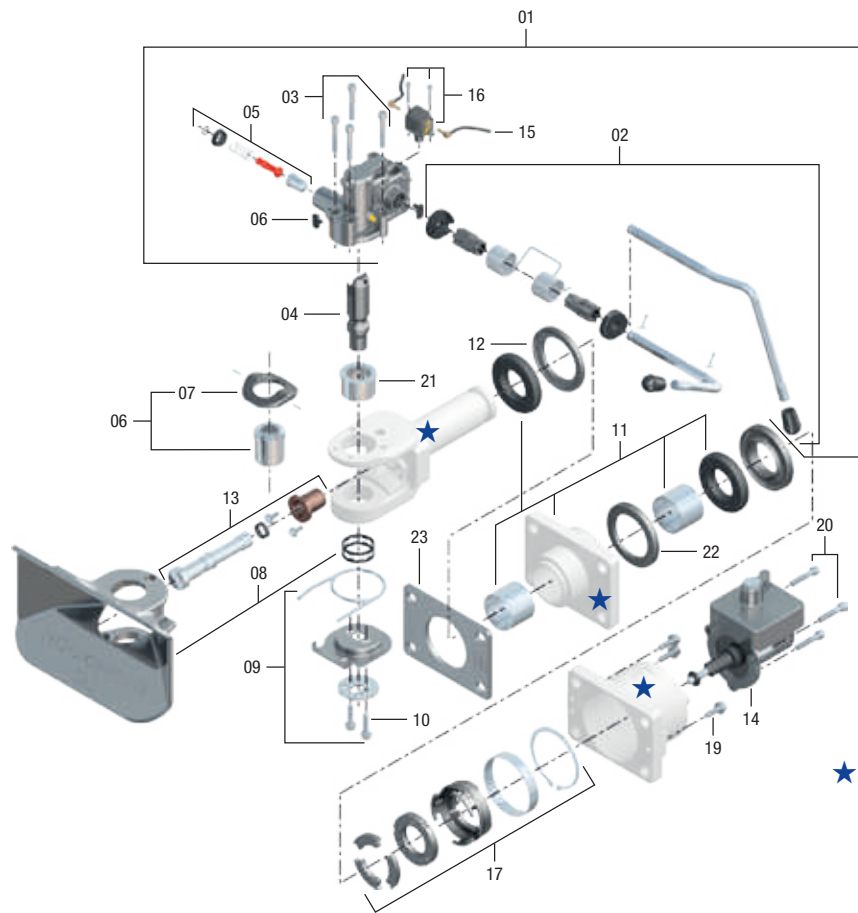

								ECE	
			D (kN)	Dc (kN)	S (kg)	V (kN)	(kg)		
RO 430A45002	145	140 x 80	100	91,5	1000	36	51,0	E1 55R-01 0406	
RO 430B45002	145	140 x 80	100	91,5	1000	36	51,0	E1 55R-01 0406	
RO 430A50002	150	160 x 100	130	91,5	1000	36	52,0	E1 55R-01 0405	
RO 430B50002	150	160 x 100	130	91,5	1000	36	52,0	E1 55R-01 0405	
RO 430A45542	145	140 x 80	100	91,5	1000	36	58,78	E1 55R-01 0406	X
RO 430A50542	150	160 x 100	130	91,5	1000	36	59,0	E1 55R-01 0405	X

RO★430

Ersatzteile • Spare parts • Pièces de rechange • Ricambi • Piezas de recambio

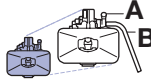

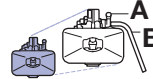
★ kein Ersatzteil
no spare part
non pièce de rechange
no ricambio
no es pieza de recambio

Pos		ROE		Pos		ROE	
01	RO xxxAxxx0/1	ROE 70937	1	10	RO 430xxx02	ROE 30486	1
01	RO 430Axxx2	ROE 71449A	1	11		ROE 25475	1
01	RO 430Bxxx2	ROE 71449B	1	12		ROE 44159	1
02	RO xxxAxxx0/1	ROE 50244	1	13		ROE 70938	1
02	RO xxxBxxx0/1	ROE 70735	1	14	RO 430xxx0	ROE 70939	1
02	RO 430Axxx2	ROE 71795A	1	14	RO 430xxx1	ROE 71611	1
02	RO 430Bxxx2	ROE 71795B	1	14	RO 430xxx2	ROE 70635	1
03		ROE 30361	1	15		ROE 70981	1
04		ROE 47099	1	15	RO 430xxx2	ROE 71380	1
05	RO 430xxx0/1	ROE 70925	1	16	RO 430xxx0 (VOSS)	ROE 90291	1
05	RO 430xxx2	ROE 71491	1	16	RO 430xxx1/2 (Schäfer)	ROE 71610	1
06		ROE 53519	1	17		ROE 59277	1
06	RO 430xxx2	ROE 71718	1	18		ROE 25479	1
07		ROE 59278	1	19		ROE 30365	1
08		ROE 46109	1	20		ROE 30364	1
09		ROE 55256	1	21		ROE 53520	1
09	RO 430xxx2	ROE 71331	1	22		ROE 45133	1
10	RO 430xxx0/1	ROE 30362	1	23		ROE 59169	1

Reparatursatz • Repair kit • Kit de réparation • Kit riparazione • Juego de reperation

Pos	ROE	ROE
04, 05, 06, 09, 18, 21	RO 430xxx0/1	ROE 71124
04, 05, 06, 09, 21	RO 430xxx2	ROE 71728

RO★433 T1 – 40 mm CH

- DE** Komfortkupplung. Spielfrei, gefedert, gedämpft, CH
- EN** Comfort hitch. Slack-free, with buffers, dampened, CH
- FR** Crochet d'attelage confort. Sans jeu, à ressorts, amorti, CH
- IT** Gancio comfort. Senza gioco, molleggiato, ammortizzato, CH
- ES** Enganche confort. Exento de juego, con almohadillas, amortiguado, CH

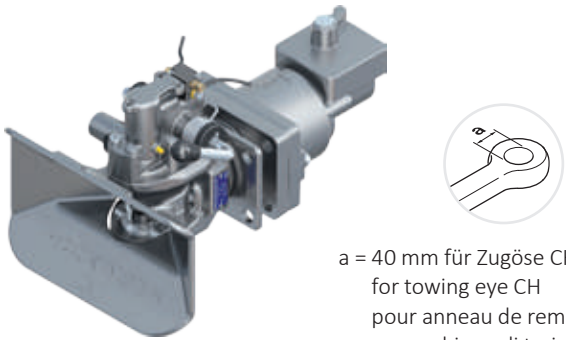

a = 40 mm für Zugöse CH
for towing eye CH
pour anneau de remorquage CH
per occhio di traino CH
para punta de lanza CH

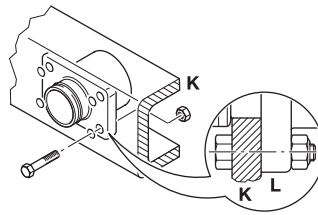
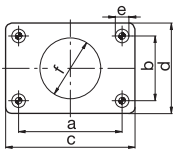
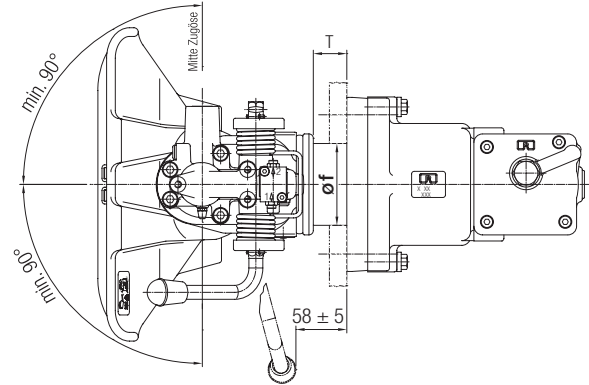
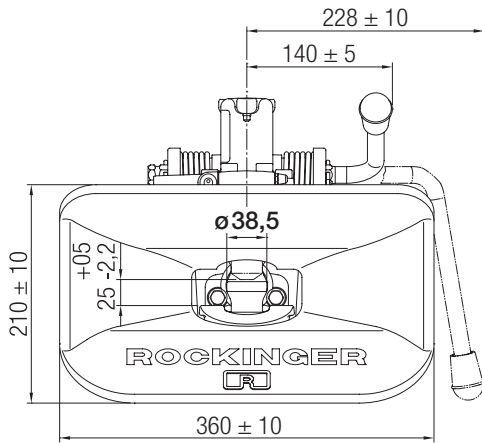
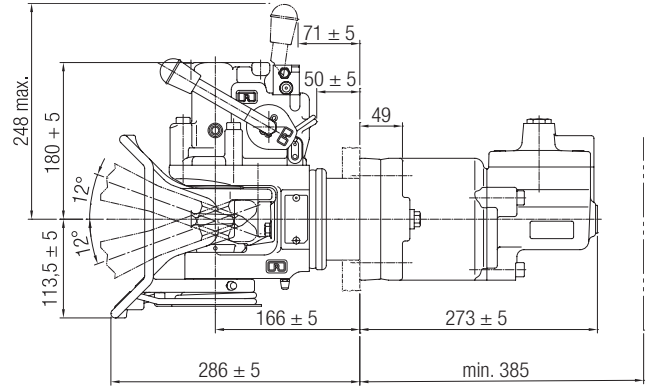

	a (mm)	b (mm)	c (mm)	d (mm)	e (mm)	f (mm)
145	140,0	80,0	180,0	120,0	17,0	84,0
150	160,0	100,0	200,0	140,0	21,0	94,0

	K (mm)	K (mm)
145	11-28	max. 28
150	11-28	max. 28





Technische Daten • Technical data • Données technique • Dati tecnici • Datos técnicos

		(mm)	D (kN)	Dc (kN)	S (kg)	V (kN)	(kg)
RO 433A45001	145	140 x 80	100	91,5	1000	36,0	51,0
RO 433A50001	150	160 x 100	130	91,5	1000	36,0	52,0
RO 433B45001	145	140 x 80	100	91,5	1000	36,0	51,0
RO 433B50001	150	160 x 100	130	91,5	1000	36,0	52,0

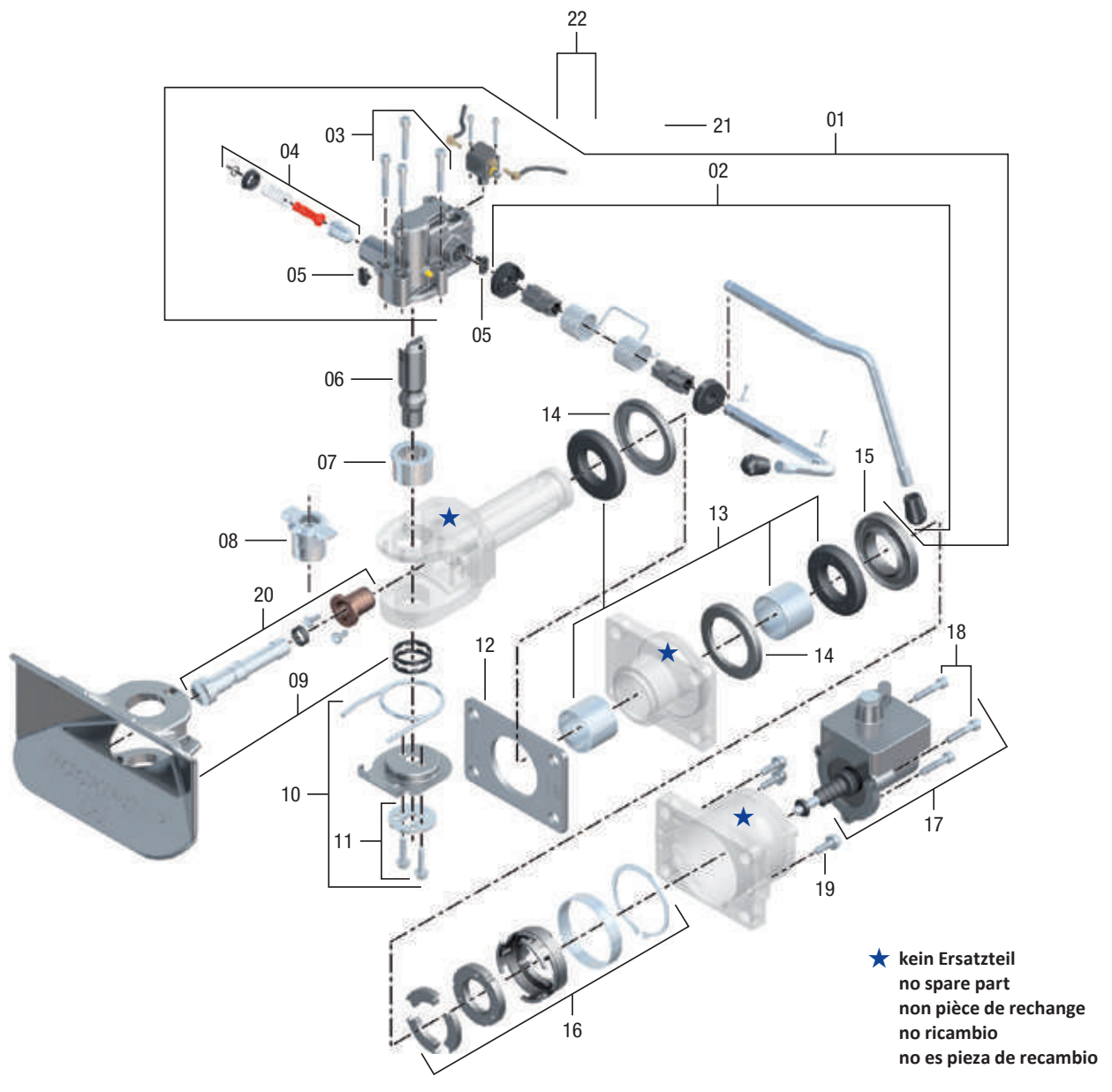
RO★433 T1 – 40 mm CH

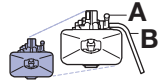
Ersatzteile • Spare parts • Pièces de rechange • Ricambi • Piezas de recambio

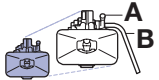

Pos		ROE		Pos		ROE	
1	RO 433Axxxx1	ROE 71449A	1	11		ROE 30486	1
1	RO 433Bxxxx1	ROE 71449B	1	12		ROE 59169	1
2	RO 433Axxxx1	ROE 71795A	1	13		ROE 25475	1
2	RO 433Bxxxx1	ROE 71795B	1	14		ROE 44159	1
3		ROE 30361	1	15		ROE 45133	1
4		ROE 71491	1	16		ROE 59277	1
5		ROE 25558	2	17		ROE 71611	1
6		ROE 47099	1	18		ROE 30364	1
7		ROE 53520	1	19		ROE 30365	1
8		ROE 53686	1	20		ROE 71096	1
9		ROE 46121	1	21		ROE 71380	1
10		ROE 71331	1	22		ROE 71610	1

RO*50 – 50 mm

- DE** Vollautomatische Anhängerkupplung
- EN** Fully automatic towing hitch
- FR** Crochet d'attelage entièrement automatique
- IT** Gancio di traino automatico
- ES** Enganche para remolque totalmente automático



a = 50 mm
DIN 74053, ECE R55-01 (Class D)

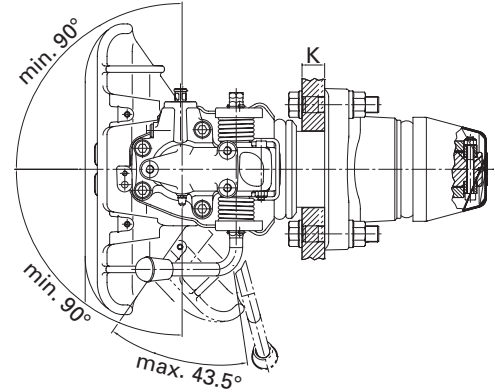
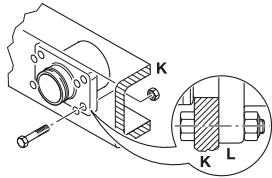
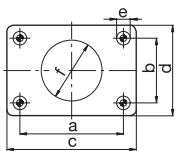
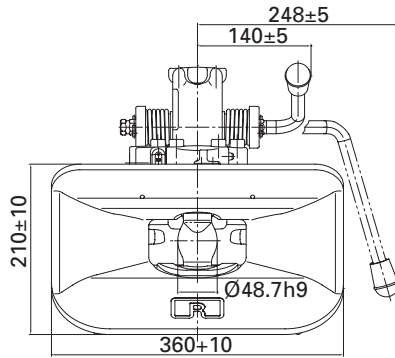
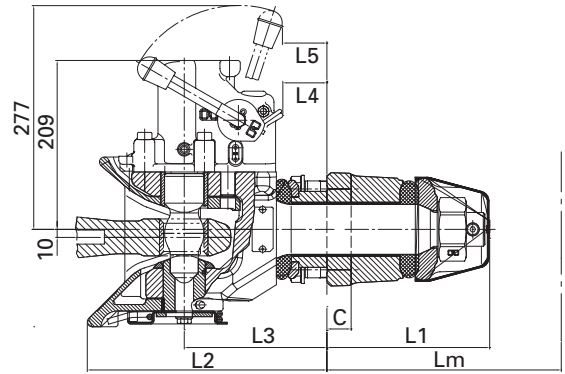

	a (mm)	b (mm)	c (mm)	d (mm)	e (mm)	f (mm)
6	160,0	100,0	200,0	140,0	21,0	94,0

	L1 (mm)	L2 (mm)	L3 (mm)	L4 (mm)	L5 (mm)	K (mm)	C (mm)	Lm (mm)
6	202	297	177	54	55	35	30	290

Technische Daten • Technical data • Données technique • Dati tecnici • Datos técnicos



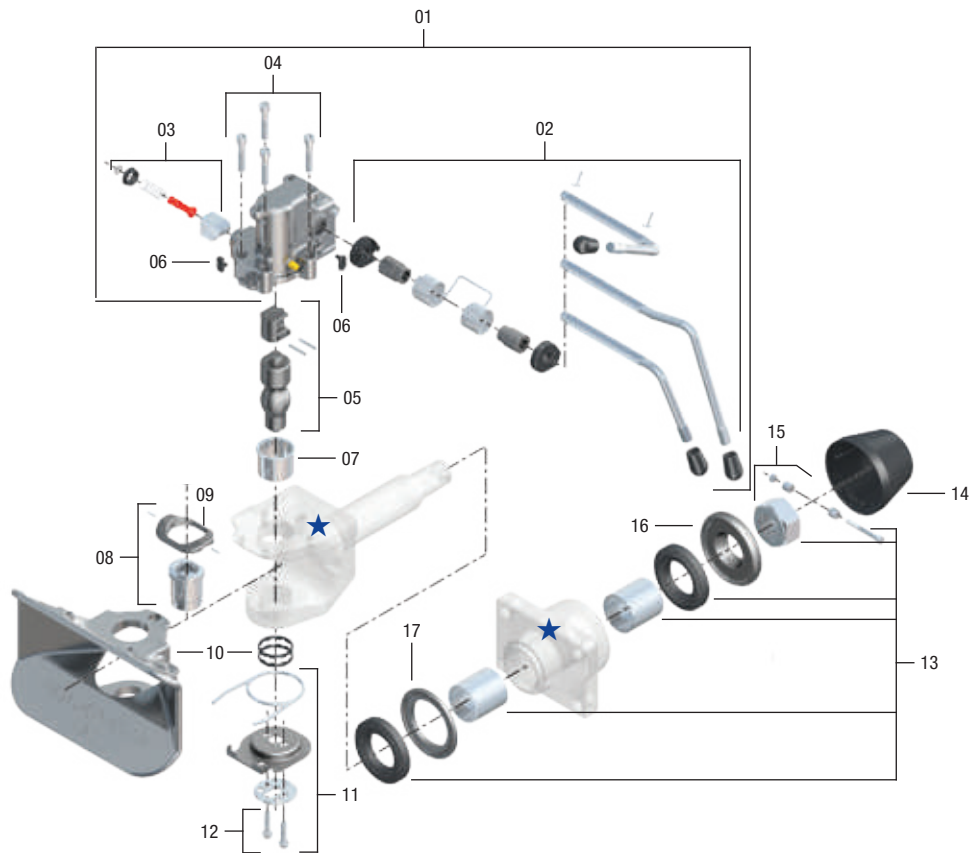

	A/B	HD	(mm)	D (kN)	Dc (kN)	S (kg)	V (kN)	(kg)	ECE				
RO 500A66000	A		160x100	200	140	1000	90	50	E1 55R-01 1844				
RO 500A66000	A		160x100	200	140	2500	60	50	E1 55R-01 1844				
RO 500B66000	B		160x100	200	140	1000	90	50,5	E1 55R-01 1844				
RO 500B66000	B		160x100	200	140	2500	60	50,5	E1 55R-01 1844				
RO 500A66200	A		160x100	200	140	1000	90	50	E1 55R-01 1844	x			
RO 500A66200	A		160x100	200	140	2500	60	50	E1 55R-01 1844	x			
RO 500A66400	A		160x100	200	140	1000	90	50	E1 55R-01 1844		x	x	
RO 500A66400	A		160x100	200	140	2500	60	50	E1 55R-01 1844		x	x	
RO 500A66550	A		160x100	200	140	2500	60	50	E1 55R-01 1844	x			x
RO 500A66550	A		160x100	200	140	1000	90	50	E1 55R-01 1844	x			x
RO 500A66500	A		160x100	285	140	2500	60	50	E1 55R-01 1844				
RO 500A66500	A		160x100	285	140	1000	90	50	E1 55R-01 1844				
RO 500B66500	B		160x100	285	140	2500	60	50,5	E1 55R-01 1844				
RO 500B66500	B		160x100	285	140	1000	90	50,5	E1 55R-01 1844				
RO 500A66620	A	x	160x100	200	140	1000	90	53,1	E1 55R-01 1844	x			
RO 500A66620	A	x	160x100	200	140	2500	60	53,1	E1 55R-01 1844	x			
RO 500A66590	A	x	160x100	200	140	1000	90	61	E1 55R-01 1844	x			x
RO 500A66590	A	x	160x100	200	140	2500	60	61	E1 55R-01 1844	x			x

RO★50

Ersatzteile • Spare parts • Pièces de rechange • Ricambi • Piezas de recambio

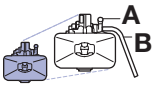

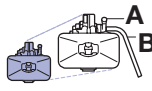
★ kein Ersatzteil
no spare part
non pièce de rechange
no ricambio
no es pieza de recambio

Pos			ROE		Pos			ROE	
01	RO xxxAxxxxx		ROE 71442A	1	08			ROE 53637	1
01	RO xxxBxxxxx		ROE 71442B	1	09			ROE 59428	1
01	RO xxxBxx530		ROE 71794B	1	10			ROE 46145	1
02	RO xxxAxxxxx		ROE 71644A	1	10		x	ROE 46165	1
02	RO xxxBxxxxx		ROE 71644B	1	11			ROE 71331	1
02	RO xxxBxx530		ROE 71800	1	12			ROE 30486	1
03			ROE 27009	1	13			ROE 71801	1
04			ROE 30417	1	14			ROE 25347	1
05			ROE 47130	1	15			ROE 71802	1
06			ROE 25558	1	16			ROE 59393	1
07			ROE 53604	1	17			ROE 44177	1

Reparatursatz • Repair kit • Kit de réparation • Kit riparazione • Juego de reparation

Pos.	ROE
03, 04, 05a, 07, 08, 11	ROE 71805

RO*50 E – 50 mm

- DE** Vollautomatische Anhängerkupplung
- EN** Fully automatic towing hitch
- FR** Crochet d'attelage entièrement automatique
- IT** Gancio di traino automatico
- ES** Enganche para remolque totalmente automático

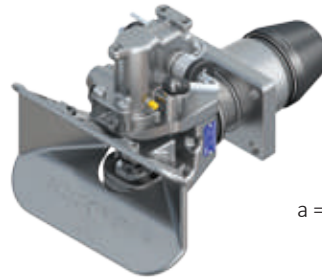

a = 50 mm
DIN 74053, ECE R55-01 (Class D)

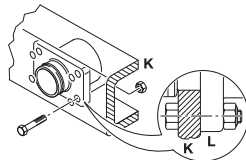
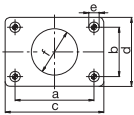
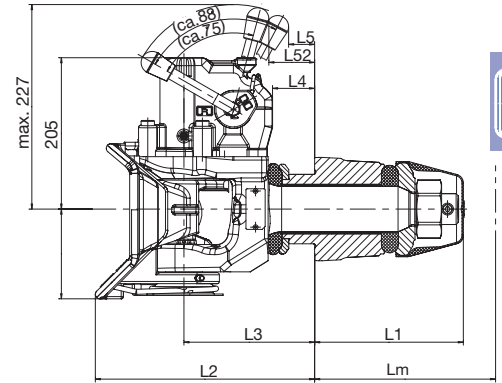
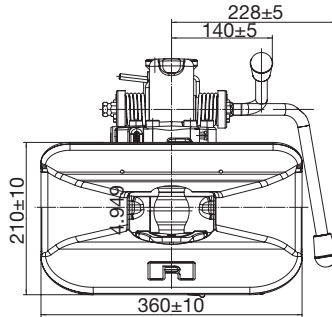
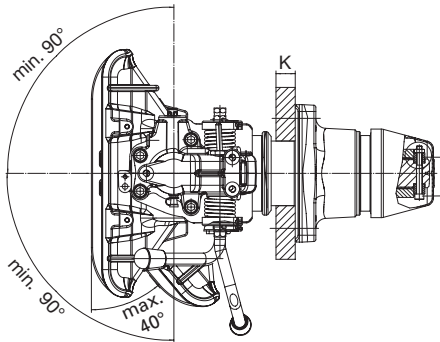

	a (mm)	b (mm)	c (mm)	d (mm)	e (mm)	f (mm)
6	160,0	100,0	200,0	140,0	21,0	94,0

	L1 (mm)	L2 (mm)	L3 (mm)	L4 (mm)	L5 (mm)	L52 (mm)	K (mm)	C (mm)	Lm (mm)
6	201,5	297	177	56,5	35	62	35	30	290

Technische Daten • Technical data • Données technique • Dati tecnici • Datos técnicos

										ECE					
	A		(mm)	D (kN)	Dc (kN)	S (kg)	V (kN)	(kg)							
RO 510A61000	A		160x100	285	140	1000	90	45	E1 55R-01 1845						
RO 510A61000	A		160x100	285	140	2500	60	45	E1 55R-01 1845						
RO 510B61000	B		160x100	285	140	1000	90	46	E1 55R-01 1845						
RO 510B61000	B		160x100	285	140	2500	60	46	E1 55R-01 1845						
RO 510A61200	A		160x100	285	140	1000	90	46	E1 55R-01 1845	x					
RO 510A61200	A		160x100	285	140	2500	60	46	E1 55R-01 1845	x					
RO 510A61400	A		160x100	285	140	1000	90	58	E1 55R-01 1845		x	x			
RO 510A61400	A		160x100	285	140	2500	60	58	E1 55R-01 1845		x	x			
RO 510A61520	A		160x100	285	140	1000	90	60	E1 55R-01 1845		x	x	x		
RO 510A61520	A		160x100	285	140	2500	60	60	E1 55R-01 1845		x	x	x		
RO 510A61540	A		160x100	285	140	1000	90	57	E1 55R-01 1845	x		x			
RO 510A61540	A		160x100	285	140	2500	60	57	E1 55R-01 1845	x		x			
RO 510A61620	A	x	160x100	285	140	1000	90	57	E1 55R-01 1845	x					
RO 510A61620	A	x	160x100	285	140	2500	60	57	E1 55R-01 1845	x					
RO 510A61590	A	x	160x100	285	140	1000	90	57	E1 55R-01 1845	x					x
RO 510A61590	A	x	160x100	285	140	2500	60	57	E1 55R-01 1845	x					x

Pneumatische Fernbedienung • Pneumatic remote control • Commande à distance pneumatique • Comandi pneumatici da remoto • Controles remotos neumáticos

Komfort, Comfort, Confort, Comodità, Confort:

ROE 71594

Einfach, Light, Simple, Semplice, Sencillo: * = (Duomatic)

ROE 71909-D

RO★50 E

Ersatzteile • Spare parts • Pièces de rechange • Ricambi • Piezas de recambio

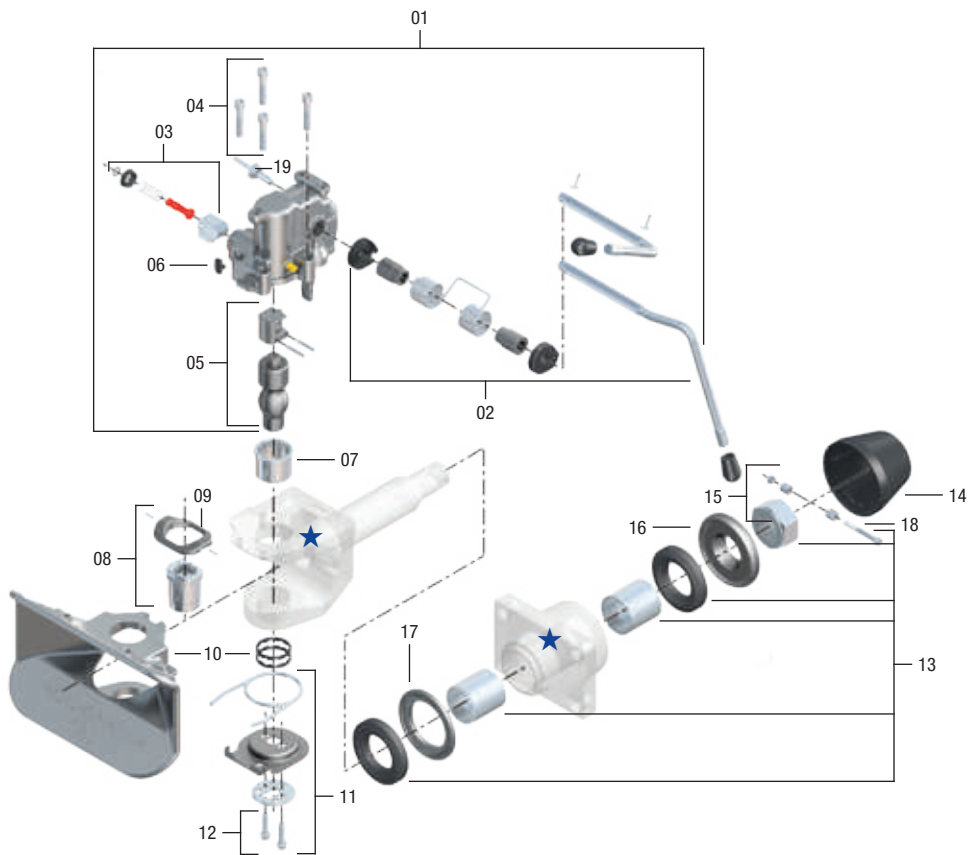

★ kein Ersatzteil
no spare part
non pièce de rechange
no ricambio
no es pieza de recambio

Pos		HD	ROE		Pos		HD	ROE	
01	RO xxxAxxxxx		ROE 71504A	1	10			ROE 46146	1
01	RO xxxBxxxxx		ROE 71504B	1	10		x	ROE 46166	1
02	RO xxxAxxxxx		ROE 71644A	1	11			ROE 71331	1
02	RO xxxBxxxxx		ROE 71644B	1	12			ROE 30486	1
03			ROE 27009	1	13			ROE 71801	
04			ROE 30417	1	14			ROE 25347	1
05			ROE 47131	1	15			ROE 71802	1
06			ROE 25558	1	16			ROE 59393	1
07			ROE 53606	1	17			ROE 44177	1
08			ROE 53605	1	18			ROE 30492	1
09			ROE 59428	1	19			ROE 71438	1

Reparatursatz • Repair kit • Kit de réparation • Kit riparazione • Juego de reperacion

Pos.	ROE
03, 04, 05, 07, 08, 11	ROE 71809

RO*50 flex – 50 mm

- DE** Anhängerkupplung für hohe Beanspruchungen und im Off-Road-Einsatz
- EN** Towing hitch for rugged conditions and off road applications
- FR** Crochet d'attelage pour sollicitations élevées et en utilisation off-road
- IT** Gancio di traino per elevate sollecitazioni e fuoristrada
- ES** Enganche para remolque para altas prestaciones fuera de la carretera



a = 50 mm
DIN 74053, ECE R55-01 (Class D)

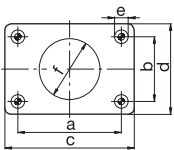
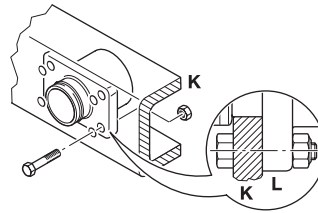
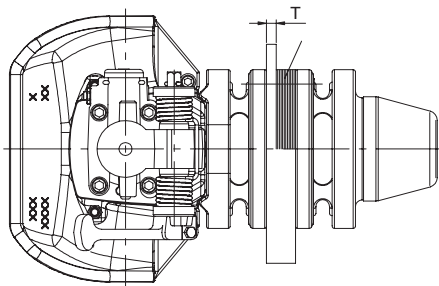
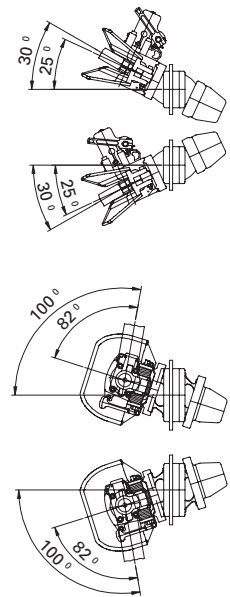
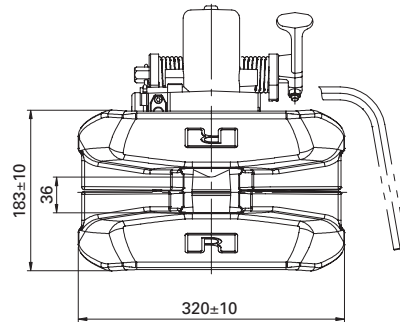
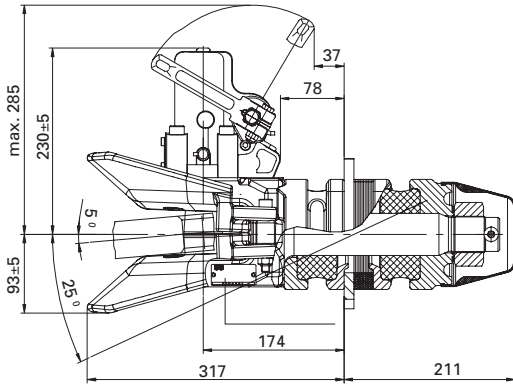

	a (mm)	b (mm)	c (mm)	d (mm)	e (mm)	f (mm)
6	160,0	100,0	200,0	140,0	21,0	94,0

	K (mm)	K (mm)
6	-	max. 35



Technische Daten • Technical data • Données technique • Dati tecnici • Datos técnicos

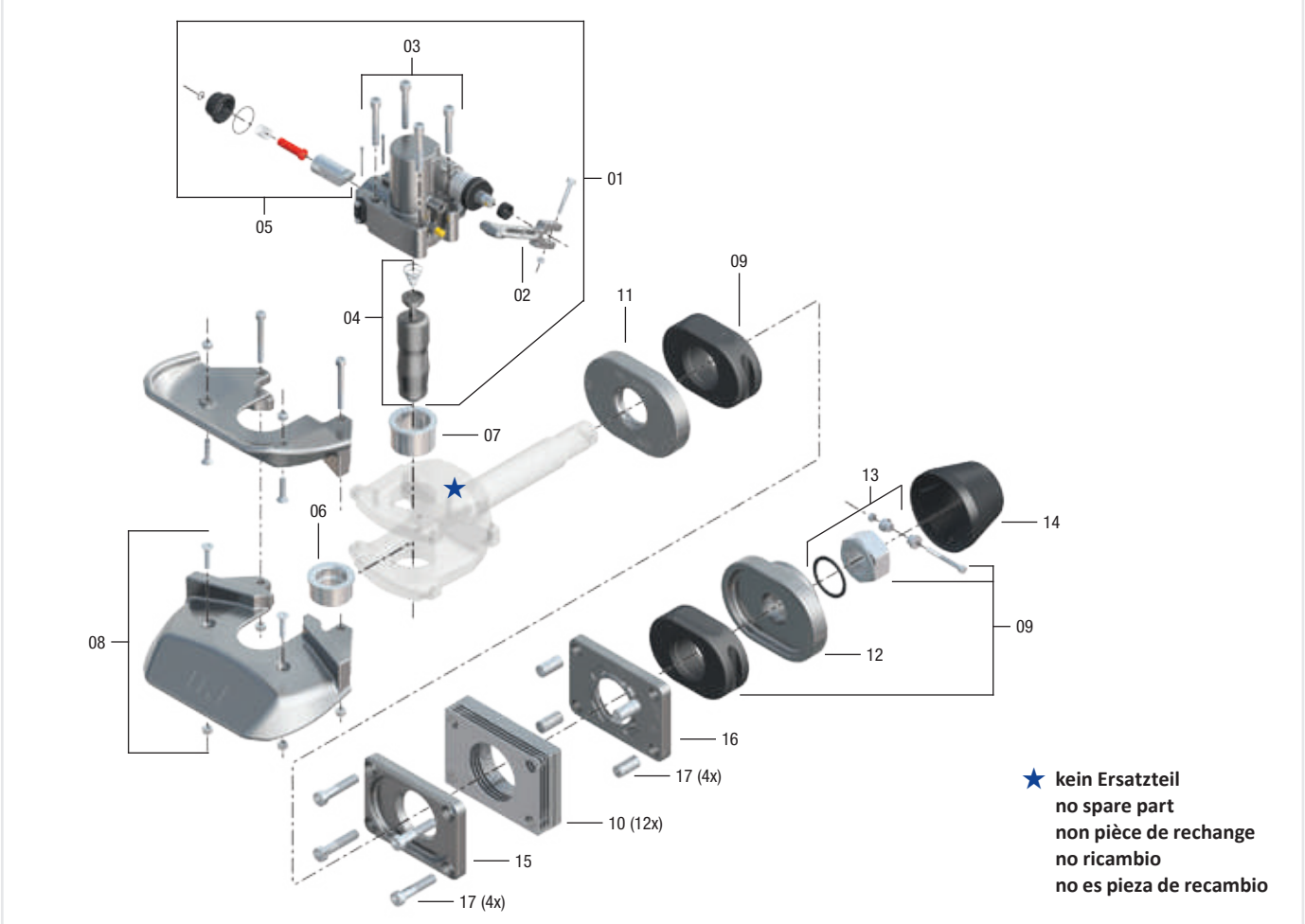

		(mm)	D (kN)	Dc (kN)	C (t)	(kg)	ECE		
RO 506 A 61001	6	160 x 100	260			57	E1 55R-01 1360		
RO 506 B 61001	6	160 x 100	260			57	E1 55R-01 1360		
RO 506 C 61401	6	160 x 100	260			66	E1 55R-01 1360	x	x
RO 506 C 61001	6	160 x 100	260			57	E1 55R-01 1360		
RO 506 D 61001	6	160 x 100	260			57	E1 55R-01 1360		

RO★50 flex

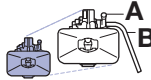
Ersatzteile • Spare parts • Pièces de rechange • Ricambi • Piezas de recambio

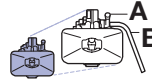

Pos		ROE	
01	RO xxxAxxx0 (2A, 3, 4, 5)	ROE 71200	1
01	RO xxxAxxx0 (2B, 3, 4, 5)	ROE 71202	1
02	RO xxxAxxxx	ROE 50257	1
02	RO xxxBxxxx	ROE 50267	1
03		ROE 30229	4
04	RO xxxxxx0	ROE 47123	1
05		ROE 71265	1
06		ROE 53551	1
07	RO xxxxxx0	ROE 53576	1
08		ROE 46126	2

Pos		ROE	
09		ROE 71266	1
10		ROE 15690	1
11		ROE 12615	1
12		ROE 43480	1
13		ROE 56122	1
14		ROE 25347	1
15		ROE 43478	1
16		ROE 43479	1
17		ROE 30399	1

RO★500 – 50 mm

- DE** Standardkupplung
- EN** Standard hitch
- FR** Crochet standard
- IT** Gancio di traino standard
- ES** Enganche estándar



a = 50 mm
DIN 74053, ECE R55-01 (Class D)

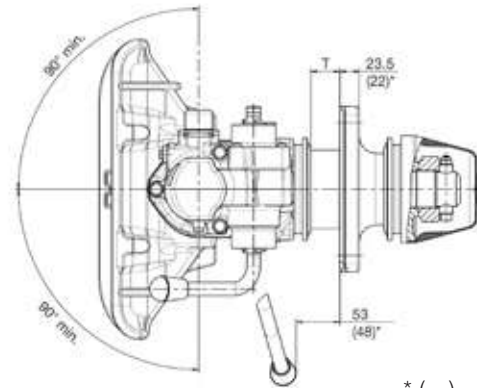
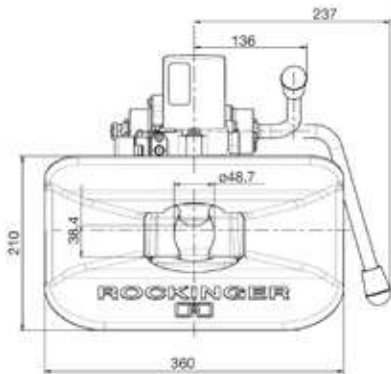
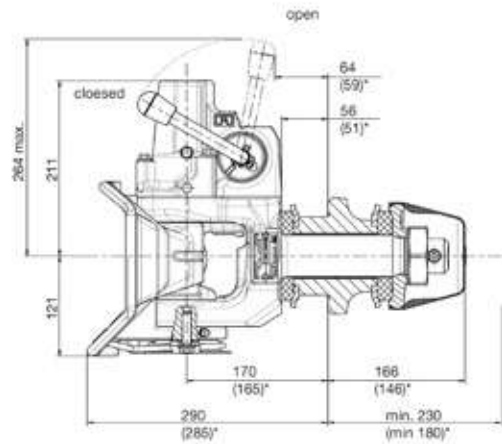

* (...) = G3

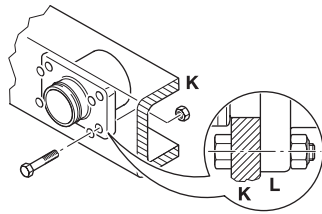
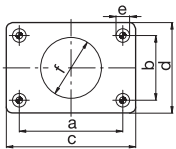

	a (mm)	b (mm)	c (mm)	d (mm)	e (mm)	f (mm)
3	120,0	55,0	155,0	90,0	15,0	74,0
4	140,0	80,0	180,0	120,0	17,0	84,0
5	160,0	100,0	200,0	140,0	21,0	94,0

	T (mm)	T (mm)
3	11-32	max. 32
4/5	11-35	max. 35





Technische Daten • Technical data • Données technique • Dati tecnici • Datos técnicos

	A B	(mm)	D (kN)	Dc (kN)	S (kg)	V (kN)	(kg)		ECE
RO 500A31004	3	120 x 55	70	70,0	500	26,4	32,0		E1 55R-01 0355
RO 500B31004	3	120 x 55	70	70,0	700	24,0	32,0		E1 55R-01 0355
RO 500A41004	4	140 x 80	100	91,5	1000	31,2	37,0		E1 55R-01 0354
RO 500B41004	4	140 x 80	100	91,5	1000	31,2	37,0		E1 55R-01 0354
RO 500A50004	5	160 x 100	130	90,0	1000	35,0	38,0		E1 55R-01 1784
RO 500B50004	5	160 x 100	130	90,0	1000	35,0	38,0		E1 55R-01 1784

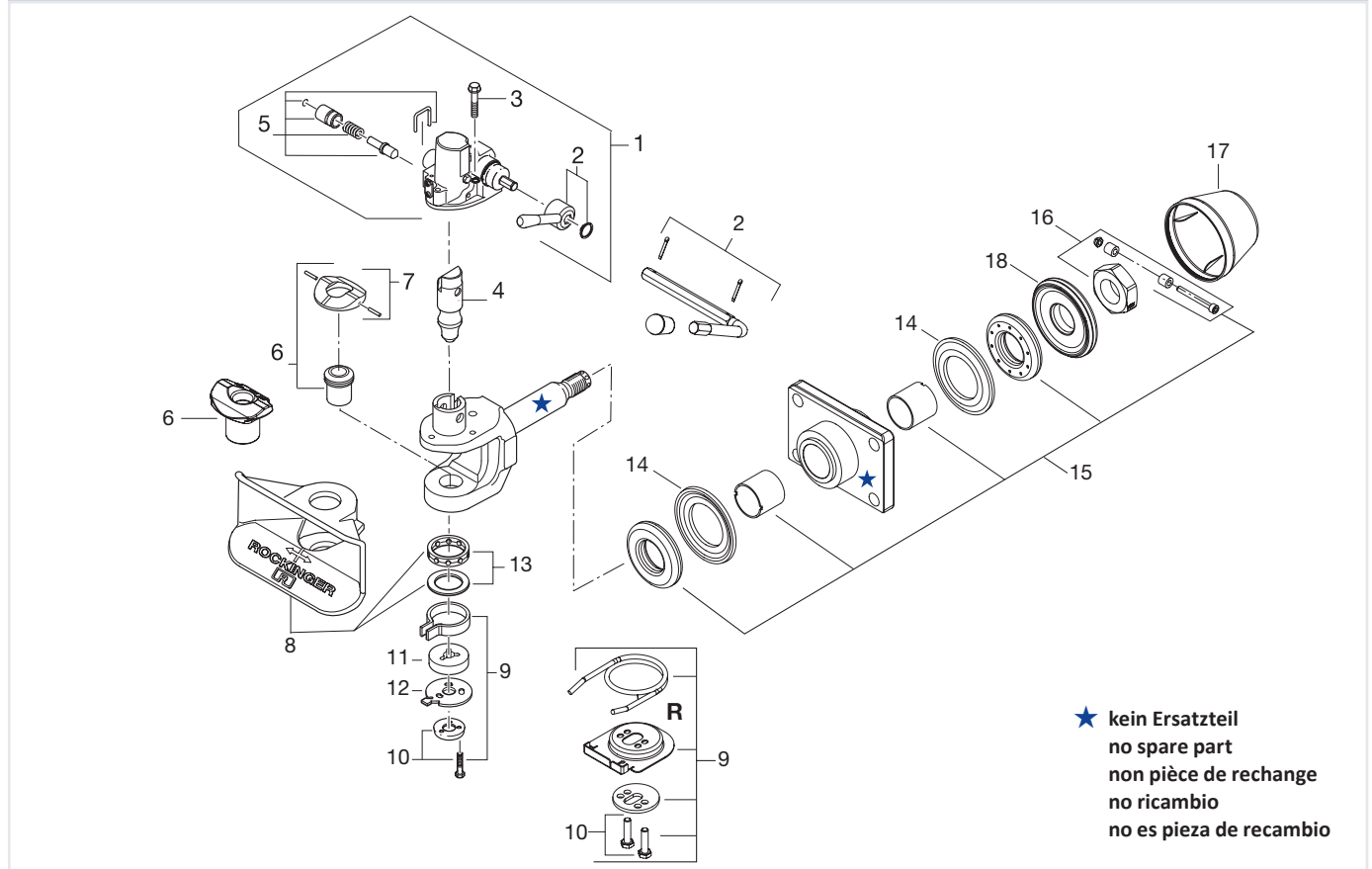
RO★500

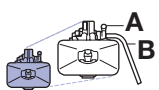
Ersatzteile • Spare parts • Pièces de rechange • Ricambi • Piezas de recambio

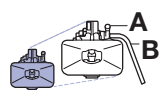

Pos		ROE		Pos		ROE	
01	RO xxxAxxxx2	ROE 70849	1	10	RO xxxxx2	ROE 30358	1
01	RO xxxAxxxx4	ROE 71858A	1	10	RO xxxxx4	ROE 30486	1
01	RO xxxBxxxx4	ROE 71858B	1	11	RO xxxxx2	ROE 53467	1
02	RO xxxAxxxx4	ROE 50294	1	12	RO xxxxx2	ROE 65626	1
02	RO xxxBxxxx4	ROE 50296	1	13	RO xxxxx2	ROE 25479	1
02	RO xxxAxxxx2	ROE 50244	1	14	3	ROE 44160	2
02	RO xxxBxxxx2	ROE 70735	1	14	4, 5	ROE 44161	2
03		ROE 30269	1	15	3	ROE 25476	1
04		ROE 47081	1	15	4, 5	ROE 25477	1
05	RO xxxxx2	ROE 70925	1	16	ROxx31xxx2	ROE 56111	1
05	RO xxxxx4	ROE 71747	1	16	ROxx41xxx2/ROxx50xx2	ROE 56112	1
06	RO xxxxx2 *	ROE 53490	1	16	ROxx31xxx4	ROE 71641	1
06	RO xxxxx2 **	ROE 53536	1	16	ROxx41xxx4/ROxx50xx4	ROE 71796	1
06	RO xxxxx4 **	ROE 53652	1	17	3	ROE 25254	1
07		ROE 70850	1	17	4, 5, 6	ROE 25347	1
07		ROE 70851	1	18	3	ROE 59279	1
08		ROE 46111	1	18	4, 5	ROE 59280	1
09	RO xxxxx2	ROE 65693	1				
09	RO xxxxx4	ROE 71331	1				

* Bronze, bronce, bronze, bronzo, bronce
** Stahl, steel, acier, acciaio, acero

Reparatursatz • Repair kit • Kit de réparation • Kit riparazione • Juego de reoperacion

Pos.	ROE	
04, 05, 06, 09	ROE 71125	RO xxxxC

RO*530 – 50 mm

- DE** Komfortkupplung. Spielfrei, gefedert, gedämpft
- EN** Comfort hitch. Slack-free, with buffers, dampened
- FR** Crochet d'attelage confort. Sans jeu, à ressorts, amorti
- IT** Gancio comfort. Senza gioco, molleggiato, ammortizzato
- ES** Enganche confort. Exento de juego, con almohadillas, amortiguado

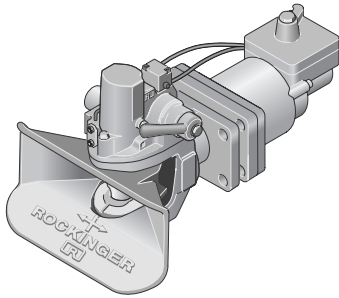

a = 50 mm
DIN 74053, ECE R55-01 (Class D)

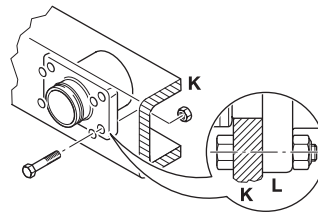
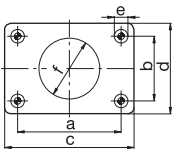
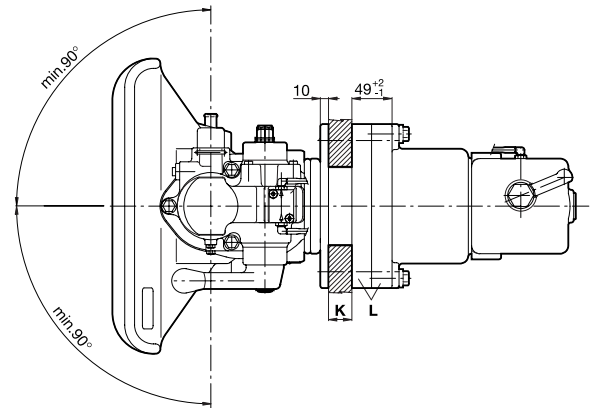
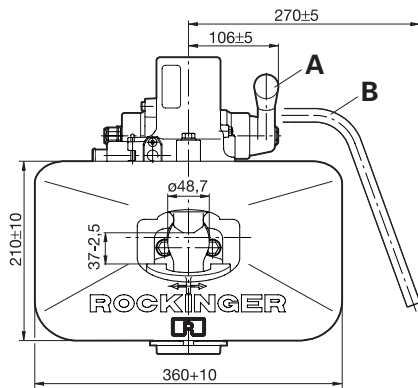
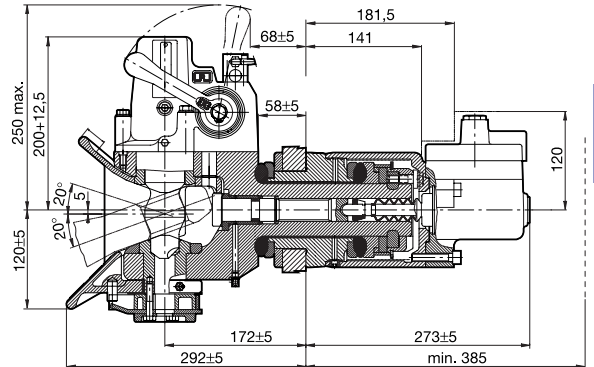

	a (mm)	b (mm)	c (mm)	d (mm)	e (mm)	f (mm)
6	160,0	100,0	200,0	140,0	21,0	94,0

	K (mm)	K (mm)
6	11-28	max. 28





Technische Daten • Technical data • Données technique • Dati tecnici • Datos técnicos

		(mm)	D (kN)	Dc (kN)	S (kg)	V (kN)	(kg)	ECE
		160 x 100	190	115	1000	50,0	54,0	E1 55R-01 0407
RO 530A60000	6	160 x 100	190	115	1000	50,0	54,0	E1 55R-01 0407
RO 530B60000	6	160 x 100	190	115	1000	50,0	54,0	E1 55R-01 0407

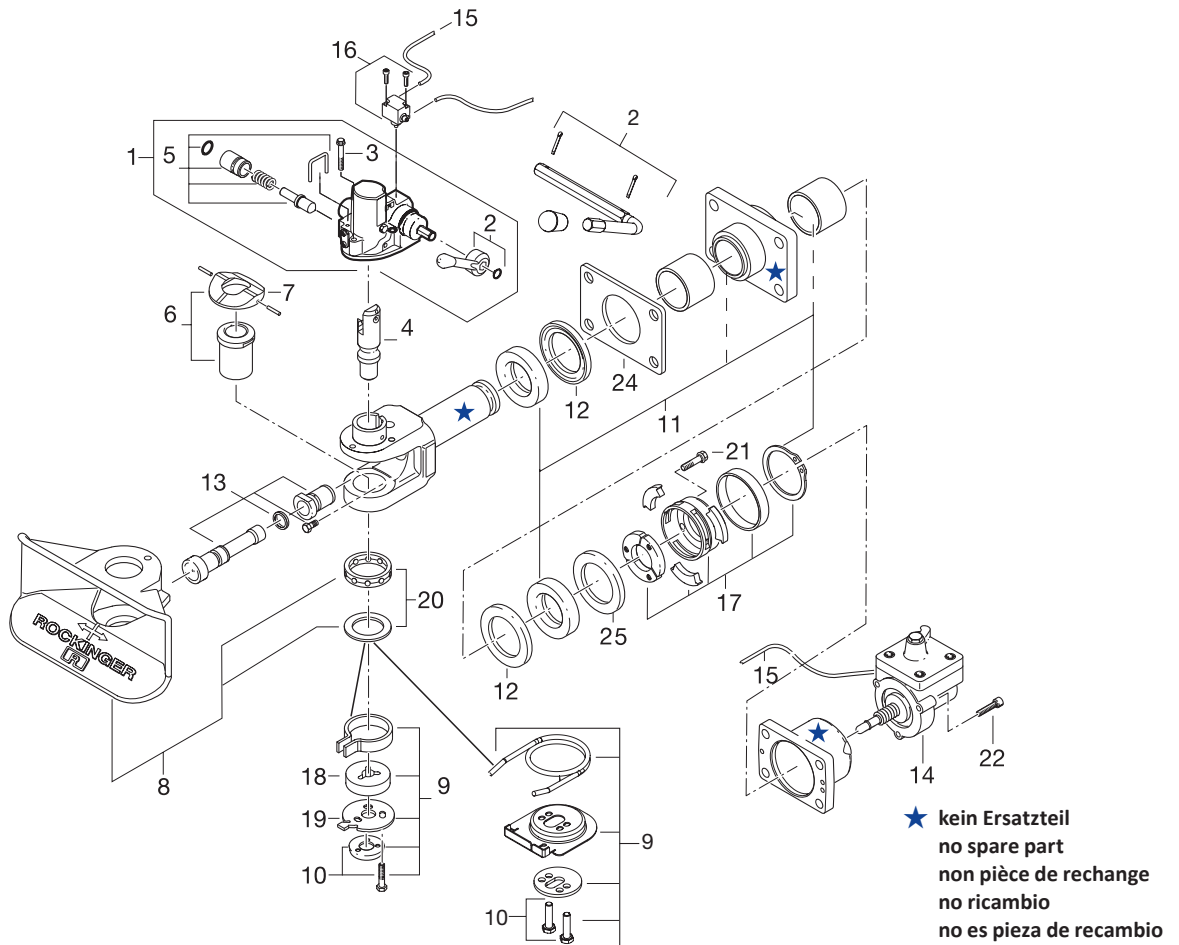
RO★530

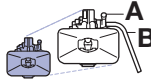
Ersatzteile • Spare parts • Pièces de rechange • Ricambi • Piezas de recambio

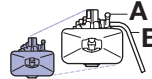

Pos		ROE		Pos		ROE	
01	RO xxxAxxxx	ROE 71869A	1	11		ROE 25475	1
01	RO xxxBxxxx	ROE 71869B	1	12		ROE 44159	1
02	RO xxxAxxx0	ROE 71644A	1	13		ROE 70948	1
02	RO xxxBxxx0	ROE 71644B	1	14		ROE 70939	1
02	RO xxxAxxxC	ROE 50244	1	15		ROE 70981	1
02	RO xxxBxxxC	ROE 70735	1	16		ROE 90291	1
03		ROE 30269	1	17		ROE 59277	1
04		ROE 47081	1	18		ROE 53467	1
05		ROE 70925	1	19		ROE 65626	1
06	RO530xxxxxxxC	ROE 53490	1	20		ROE 25479	1
06	RO530xxxxxx0	ROE 53683	1	21		ROE 30365	1
07		ROE 70850	1	22		ROE 30364	1
07		ROE 70851	1	24		ROE 59169	1
08		ROE 46111	1	25		ROE 45133	1
09	RO xxxxC	ROE 65693	1	Kit	04, 05, 06, 09 RO xxxxC	ROE 71125	1
09	RO xxxx0	ROE 71331	1				
10	RO xxxxC	ROE 30358	1				
10	RO xxxx0	ROE 30486	1				

RO*560 – 50 mm

- DE** Kupplung mit Flansch
- EN** Hitch with flange
- FR** Crochet avec bride
- IT** Gancio con flangia
- ES** Enganche con brida



a = 50 mm
DIN 74053, 94/20/CE
ISO 1102, ROE 57005

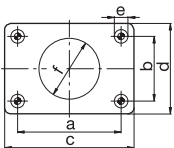
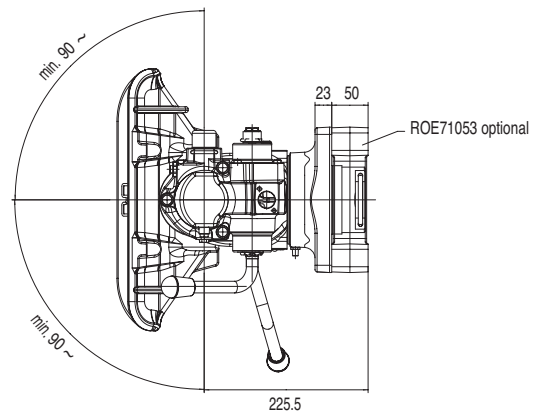
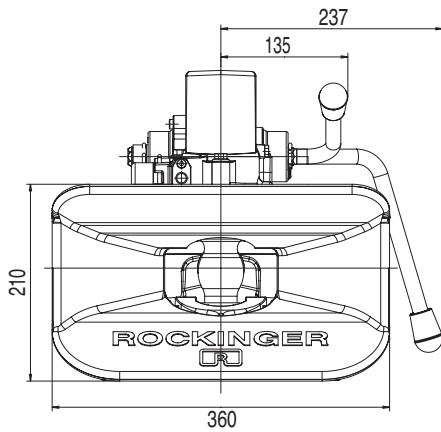
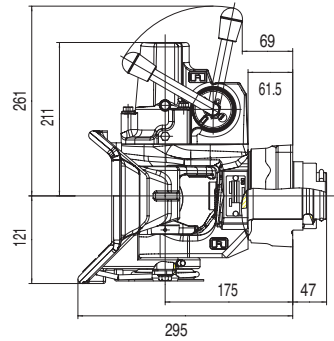

	a (mm)	b (mm)	c (mm)	d (mm)	e (mm)	f (mm)
6	160,0	100,0	200,0	140,0	21,0	94,0

Technische Daten • Technical data • Données technique • Dati tecnici • Datos técnicos



								ECE
			D (kN)	Dc (kN)	S (kg)	V (kN)		
RO 560A6000	6	160 x 100	190	106	1000	45,6	38,0	E1 55R-01 0404
RO 560A6000	6	160 x 100	190	106	2000	35,8	38,0	E1 55R-01 0404
RO 560B6000	6	160 x 100	190	106	1000	45,6	38,0	E1 55R-01 0404
RO 560B6000	6	160 x 100	190	106	2000	35,8	38,0	E1 55R-01 0404

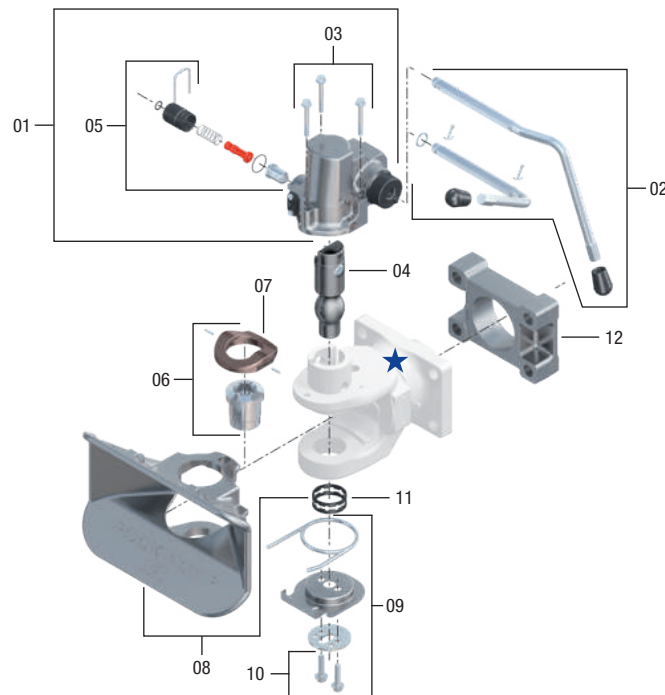

RO★560

Ersatzteile • Spare parts • Pièces de rechange • Ricambi • Piezas de recambio

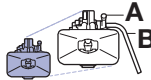

★ kein Ersatzteil
no spare part
non pièce de rechange
no ricambio
no es pieza de recambio

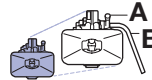
Pos		ROE	
01	RO xxxAxxxx0	ROE 71858A	1
01	RO xxxBxxxx0	ROE 71858B	1
02	RO xxxAxxxx0	ROE 50294	1
02	RO xxxBxxxx0	ROE 50296	1
03		ROE 30269	1
04		ROE 47081	1
05	RO xxxxx0	ROE 71747	

Pos		ROE	
06	RO xxxxx0 *	ROE 53683	1
07		ROE 70850	1
07		ROE 70851	1
08		ROE 46111	1
09	RO xxxxx0	ROE 71331	1
10	RO xxxxx0	ROE 30486	1
12		ROE 71053	1

* Bronze, bronze, bronze, bronzo, bronce

Reparatursatz • Repair kit • Kit de réparation • Kit riparazione • Juego de reperation

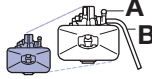
Pos.	ROE	
04, 05, 06, 09	ROE 71125	RO xxxxC

RO*56 E / 561 – 50 mm

- DE** Schwerlastkupplung mit Vertikalgelenk
- EN** Heavy duty hitch with vertical articulating hitch head
- FR** Crochet d'attelage pour lourdes charges à articulation verticale
- IT** Gancio per traini eccezionali con campana snodata
- ES** Enganche de carga pesada con articulación vertical

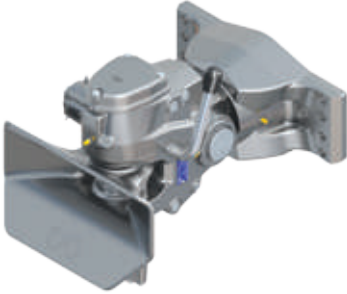

a = 50 mm
 nur Schwerlastzugöse
 only heavy duty towing eye
 uniquement anneau de remorquage pour lourdes charges
 solo occhione di traino eccezionali
 sólo punta de lanza para cargas pesadas
 ROE 57005

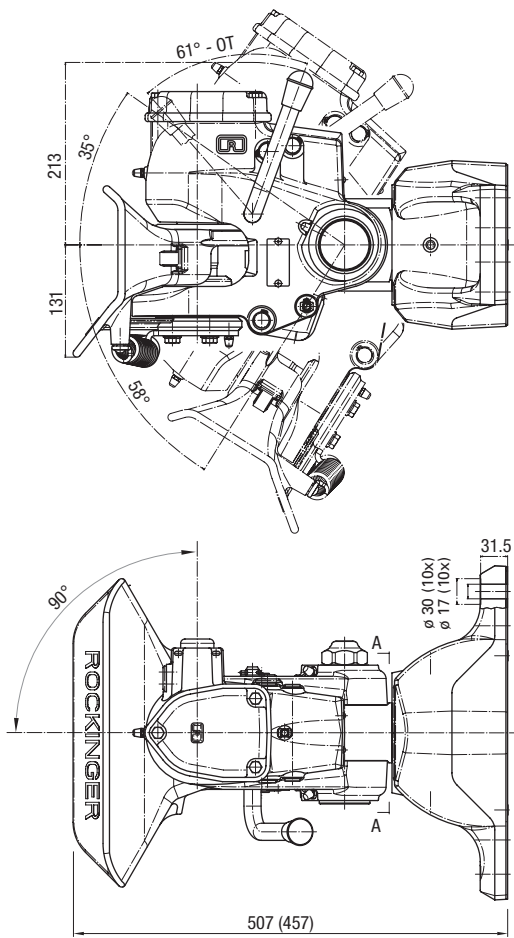

RO*56 E (RO*561E)

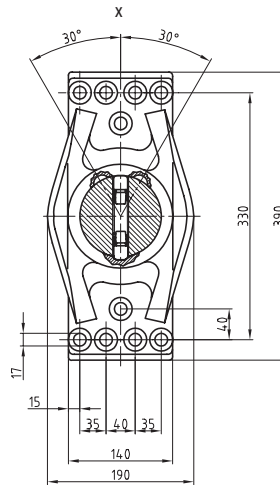

RO 567A8000 (RO*56E)

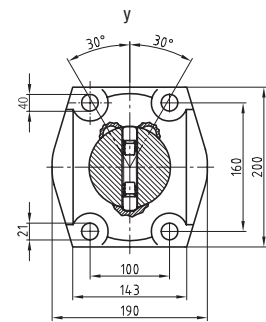

RO 567A66000 (RO*561E)



Technische Daten • Technical data • Données technique • Dati tecnici • Datos técnicos

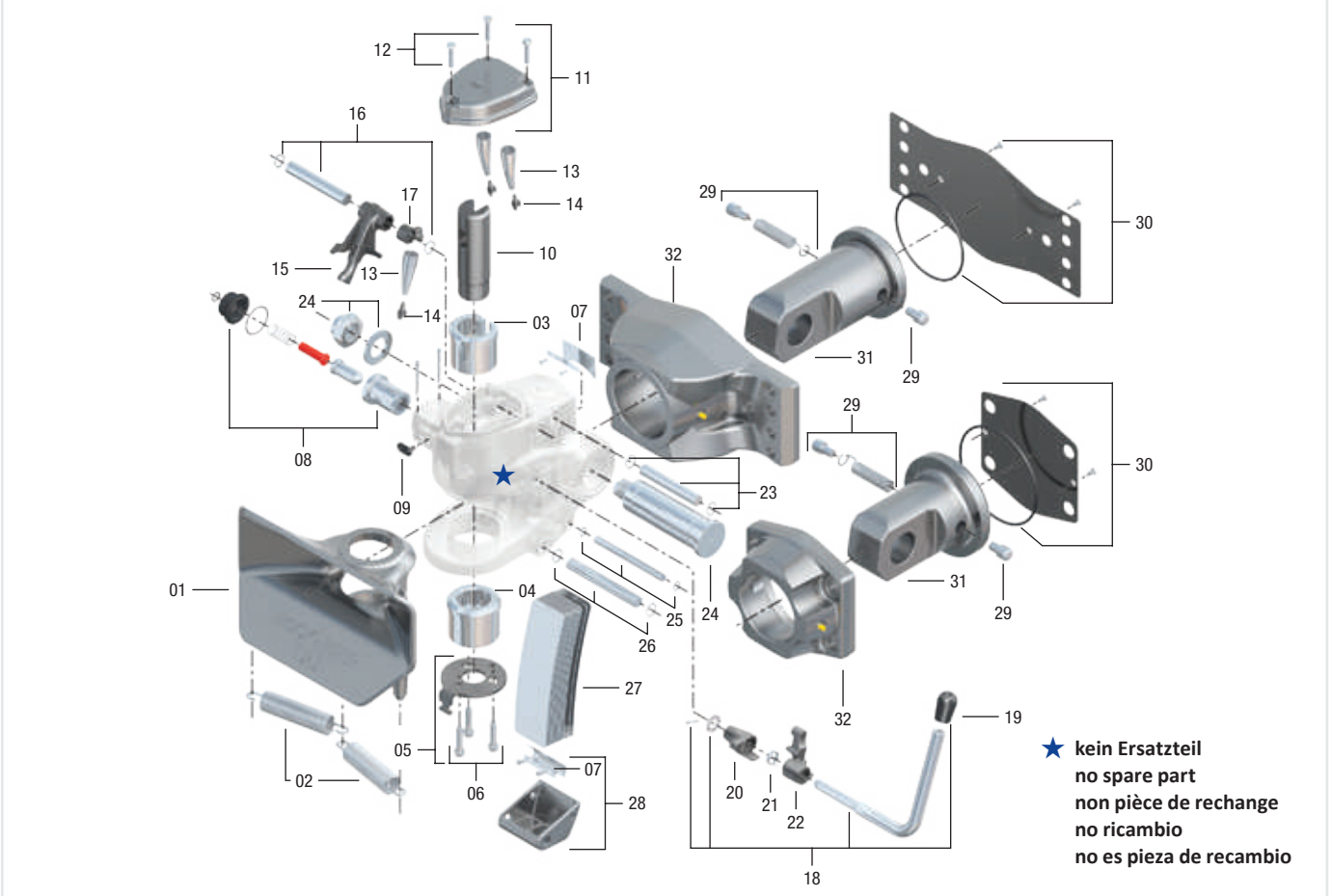

							ECE
			(mm)	D (kN)	S (kg)	(kg)	
RO 567A8000	A		x	314		80	E1 55R-01 1630
RO 567A6600	A	6	y	200		60	E1 55R-01 1631

RO*56 E / 561 – 50 mm

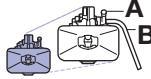
Ersatzteile • Spare parts • Pièces de rechange • Ricambi • Piezas de recambio

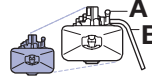

Pos		ROE	
01		ROE 46020	1
01a	(1 + 3)	ROE 71740	1
02		ROE 55005	2
03		ROE 53643	1
04		ROE 53642	1
05		ROE 59453	1
06		ROE 30441	1
07		ROE 25010	2
08		ROE 52575	1
09		ROE 25558	2
10		ROE 47139	1
11		ROE 45484	1
12		ROE 30019	1
13		ROE 55024	3
14		ROE 13005	3
15		ROE 51228	1
16		ROE 52002	1
17		ROE 65010	1

Pos		ROE	
18		ROE 50092	1
19		ROE 25104	1
20		ROE 51012	1
21		ROE 55025	1
22		ROE 51013	1
23		ROE 52011	1
24		ROE 52578	1
25		ROE 52010	1
26		ROE 52009	1
27		ROE 55026	1
28		ROE 65066	1
29		ROE 52014	1
30	56	ROE 54274	1
	561	ROE 54276	1
31	56	ROE 42016	1
	561	ROE 42014	1
32		siehe Reparatursatz	

Reparatursatz • Repair kit • Kit de réparation • Kit riparazione • Juego de reperation

Pos.	ROE	
03, 04, 10, 21, 24, 25, 27, 29, 30, 31, 32	ROE 71746	561/A66
03, 04, 10, 21, 24, 25, 27, 29, 30, 31, 32	ROE 71745	56/A80

RO*57 – 57 mm

- DE** Standardkupplung
- EN** Standard hitch
- FR** Crochet standard
- IT** Gancio di traino standard
- ES** Enganche estándar



a = 57,5 mm
 Schwedische Norm
 Swedish standard
 Norme suédoise
 Normativa svedese
 Norma sueca

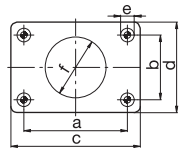
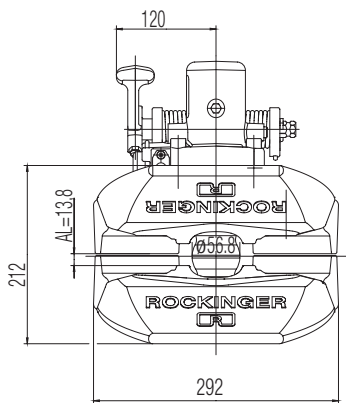

	a (mm)	b (mm)	c (mm)	d (mm)	e (mm)	f (mm)
6	160,0	100,0	200,0	140,0	21,0	94,0

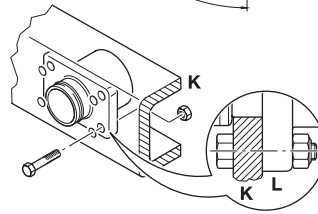
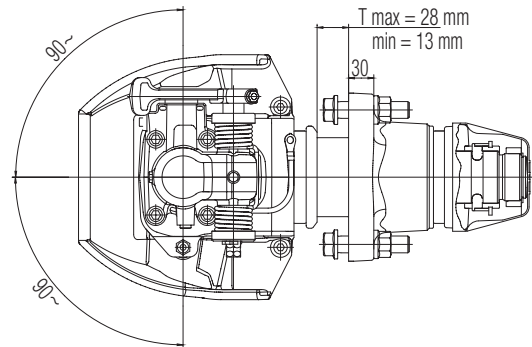
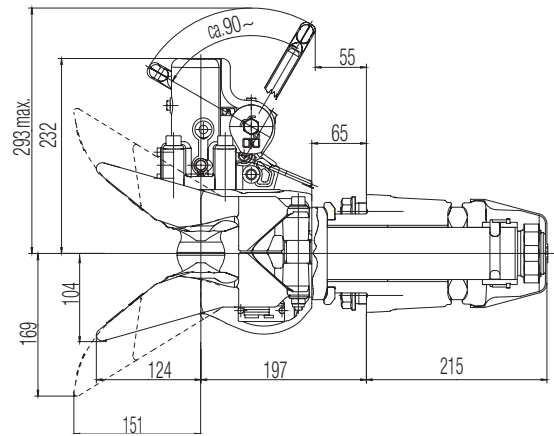

	K (mm)	K (mm)
6	13-28	max. 28

Technische Daten • Technical data • Données technique • Dati tecnici • Datos técnicos



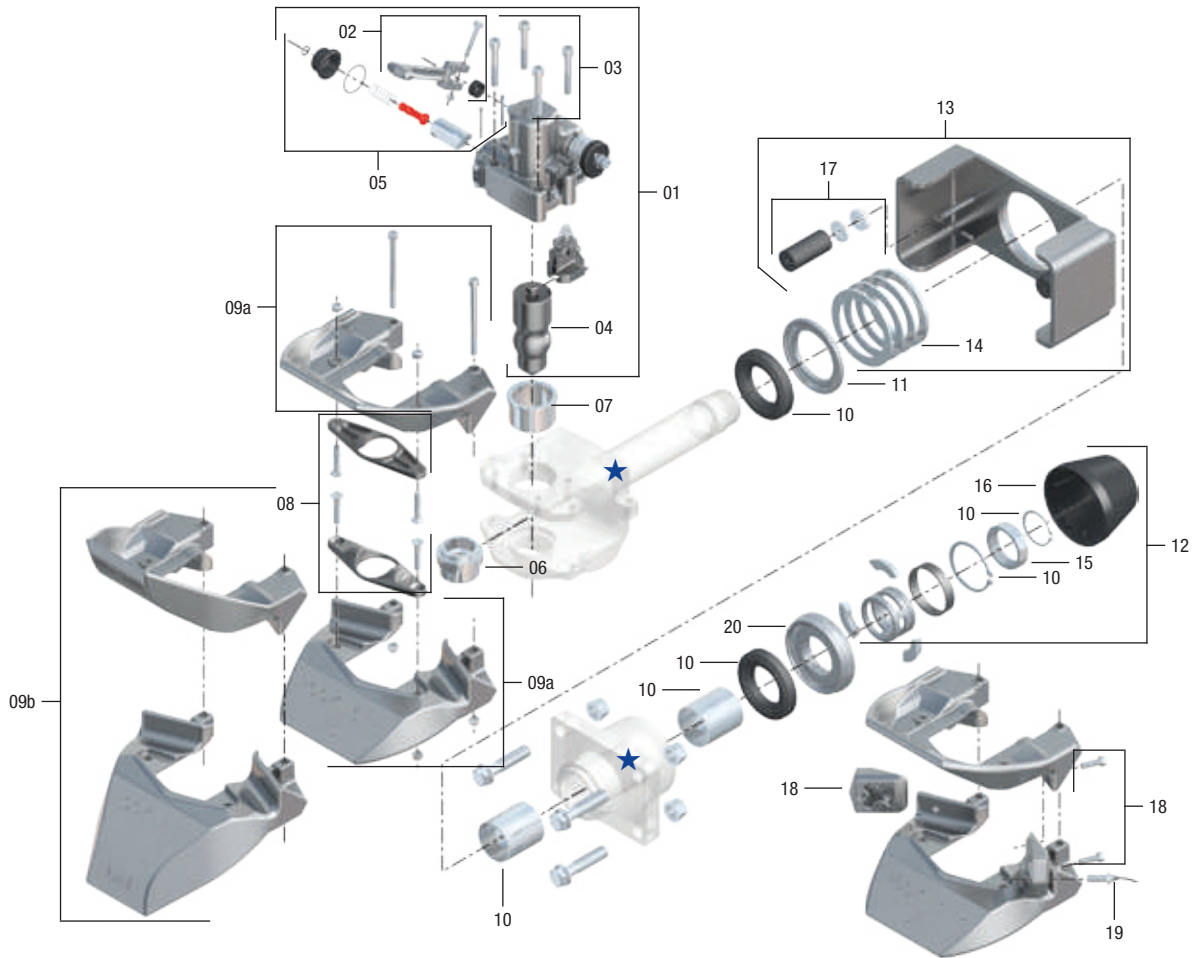

C D A B	mm	Truck		Trailer		Av (t)	ECE	kg	Light	Lock	Bracket	a b
		D (kN)	Dc (kN)	S (kg)	V (kN)							
RO 570C61000	160 x 100	300	145	1000	95	18	E1 55R-01 1361	69			x	
RO 570D61000	160 x 100	300	145	1000	95	18	E1 55R-01 1361	69			x	
RO 570C61200	160 x 100	300	145	1000	95	18	E1 55R-01 1361	69	x		x	
RO 570C61400	160 x 100	300	145	1000	95	18	E1 55R-01 1361	75	x	x	x	
RO 570C61500	160 x 100	300	145	1000	95	18	E1 55R-01 1361	66	x	x		
RO 570C61510	160 x 100	300	145	1000	95	18	E1 55R-01 1361	60				
RO 570C61540	160 x 100	300	145	1000	95	18	E1 55R-01 1361	63				a
RO 570C61560	160 x 100	300	145	1000	95	18	E1 55R-01 1361	69	x	x		a
RO 570C61570	160 x 100	300	145	1000	95	18	E1 55R-01 1361	75	x	x		a, b

RO*57

Ersatzteile • Spare parts • Pièces de rechange • Ricambi • Piezas de recambio

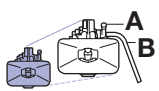

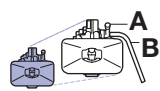
★ kein Ersatzteil
no spare part
non pièce de rechange
no ricambio
no es pieza de recambio

Pos		ROE		Pos		ROE	
01	RO xxxCxxxx (2C, 3, 4, 5)	ROE 71192	1	10		ROE 71155	1
01	RO xxxDxxxx (2D, 3, 4, 5)	ROE 71198	1	11		ROE 44177	1
02	RO xxxD6155C	ROE 71644B1	1	12		ROE 71156	1
02	RO xxxCxxxx	ROE 50257	1	13	14, 17	ROE 71157	1
02	RO xxxDxxxx	ROE 50258	1	14		ROE 71158	1
03		ROE 30229	1	15		ROE 56120	1
04		ROE 47116	1	16		ROE 25347	1
05		ROE 71153	1	17		ROE 71211	1
06		ROE 53544	1	18	RO 570x6155x	ROE 46152	2
07		ROE 53543	1	19	RO 570x6155x	ROE 70983	2
08		ROE 71154	2	20		ROE 44176	1
09a	RO 570x6155C	ROE 46122N	2				
09a		ROE 71161	2				
09b		ROE 71162	2				

RO*57 flex – 57 mm

- DE** Anhängerkupplung für hohe Beanspruchungen und im Off-Road-Einsatz
- EN** Towing hitch for rugged conditions and off road applications
- FR** Crochet d'attelage pour sollicitations élevées et en utilisation off-road
- IT** Gancio di traino per elevate sollecitazioni e fuoristrada
- ES** Enganche para remolque para altas prestaciones fuera de la carretera



a = 57,5 mm
 Schwedische Norm
 Swedish standard
 Norme suédoise
 Normativa svedese
 Norma sueca

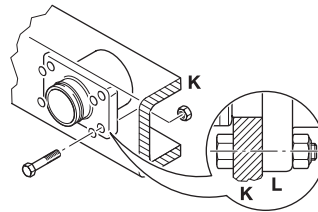
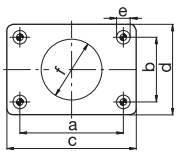
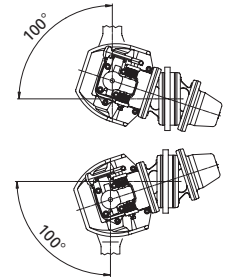
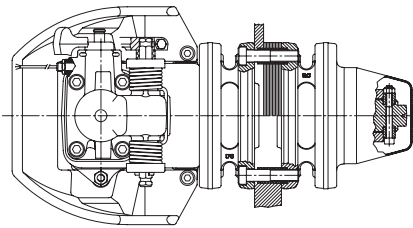
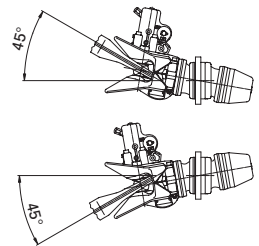
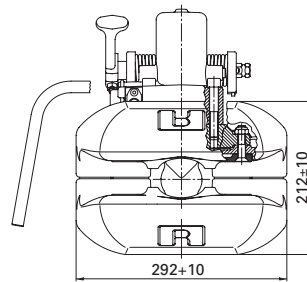
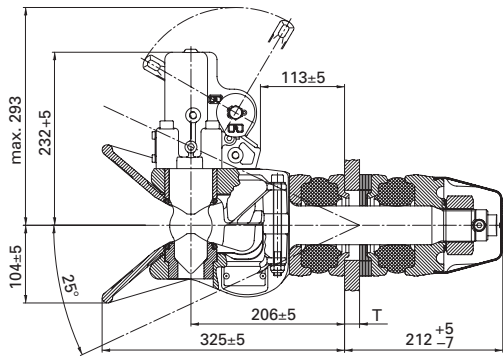

	a (mm)	b (mm)	c (mm)	d (mm)	e (mm)	f (mm)
6	160,0	100,0	200,0	140,0	21,0	94,0

	K (mm)	K (mm)
6	-	max. 35

Technische Daten • Technical data • Données technique • Dati tecnici • Datos técnicos



		 (mm)			 S (kg)	 V (kN)	 (kg)	ECE			 b a
			D (kN)	Dc (kN)							
RO 576C61000	6	160 x 100	260				57	E1 55R-01 2535			
RO 576D61000	6	160 x 100	260				57	E1 55R-01 2535			
RO 576C61400	6	160 x 100	260				63	E1 55R-01 2535	x	x	
RO 576C61560	6	160 x 100	260				65	E1 55R-01 2535	x	x	a

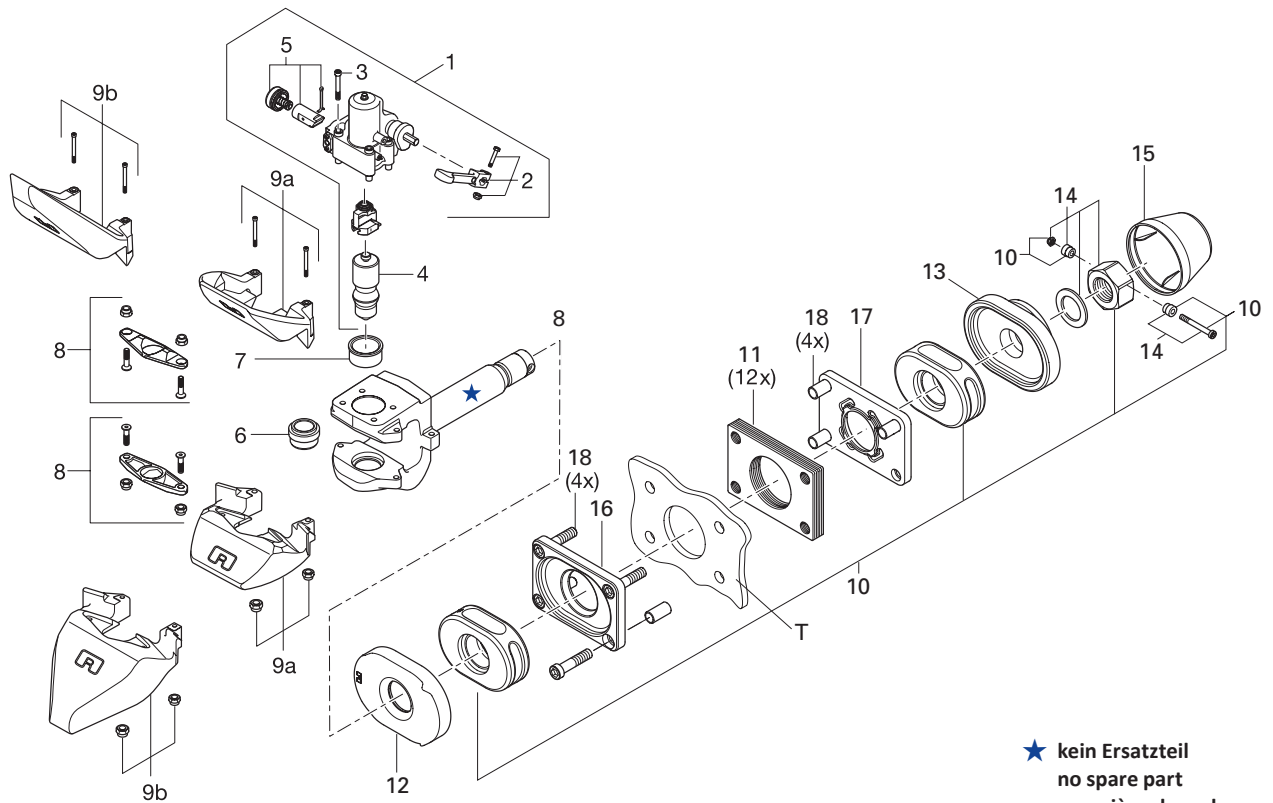

RO★57 flex

Ersatzteile • Spare parts • Pièces de rechange • Ricambi • Piezas de recambio

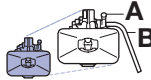

★ kein Ersatzteil
no spare part
non pièce de rechange
no ricambio
no es pieza de recambio

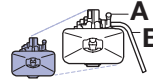
Pos		ROE	
01	RO xxxCxxxx (2C, 3, 4, 5)	ROE 71192	1
01	RO xxxDxxxx (2D, 3, 4, 5)	ROE 71198	1
02	RO xxxCxxxx	ROE 50257	1
02	RO xxxDxxxx	ROE 50258	1
03		ROE 30329	1
04		ROE 47116	1
05		ROE 71153	1
06		ROE 53544	1
07		ROE 53543	1
08		ROE 71154	1
09a		ROE 71161	1
09b		ROE 71162	1

Pos		ROE	
10		ROE 71266	1
11		ROE 15690	1
12		ROE 12615	1
13		ROE 43480	1
14		ROE 56122	1
15		ROE 25347	1
16		ROE 43478	1
17		ROE 43479	1
18		ROE 30399	1

RO*50 BNA – 68 mm

- DE** 68 mm Anhängerkupplung für BNA-Ringzugösen
- EN** 68 mm towing hitch for BNA ring towing eyes
- FR** Crochet d'attelage 68 mm pour anneau torique de traction BNA
- IT** Gancio di traino 68 mm per occhioni BNA
- ES** Enganche para remolque de 68 mm para punta de lanza en forma de anillo-BNA



a = 68 mm
 NF R 41-102
 Ringzugöse • towing eye •
 anneau de remorquage • occhione
 torico • argolla de tracción anular

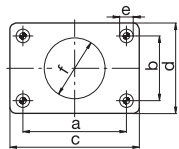
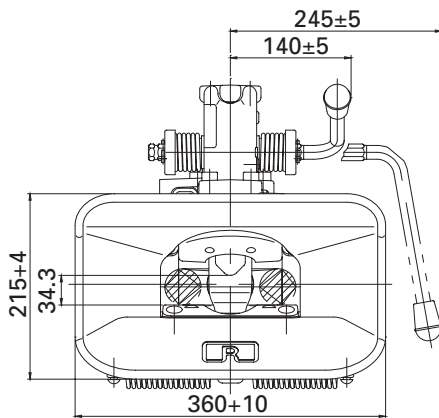

	a (mm)	b (mm)	c (mm)	d (mm)	e (mm)	f (mm)
U6	160,0	100,0	200,0	140,0	21,0	94,0

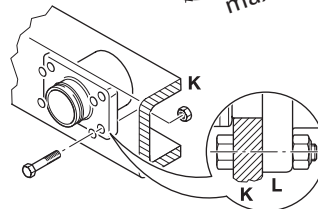
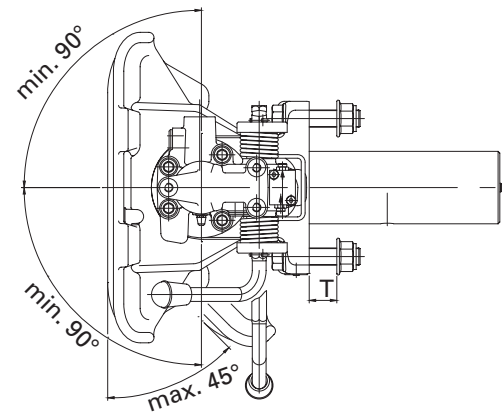
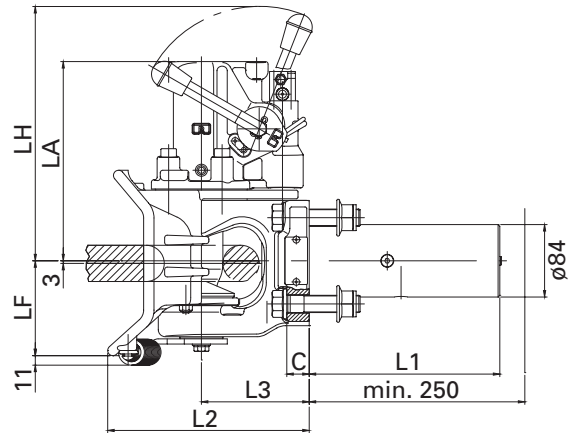

	LH (mm)	LA (mm)	LF (mm)	L1 (mm)	L2 (mm)	L3 (mm)	C (mm)	T (mm)
U6	295,0	231,0	110,0	234,0	234,0	125,0	26,0	32,0

Technische Daten • Technical data • Données technique • Dati tecnici • Datos técnicos



C D A B	U6	(mm)	Truck		Trailer		(kg)	ECE	ECE	ECE
			D (kN)	Dc (kN)	S (kg)	V (kN)				
RO 590A61001	U6	160 x 100	200	140	1000	75	40	E1 55R-01 1614		
RO 590B61001	U6	160 x 100	200	140	1000	75	40,5	E1 55R-01 1614		
RO 590A61401	U6	160 x 100	200	140	2500	50	53	E1 55R-01 1614	X	X
RO 590A61511	U6	160 x 100	200	150	1000	50	52	E1 55R-01 1614	X	X

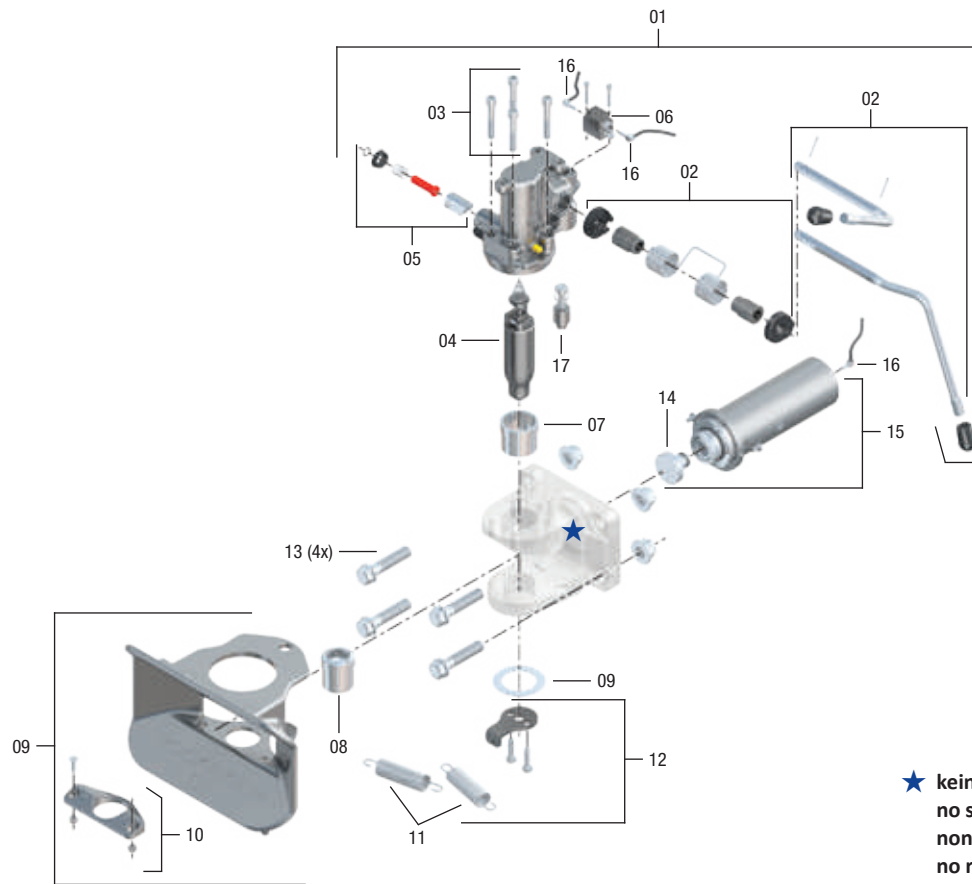

RO★50 BNA

Ersatzteile • Spare parts • Pièces de rechange • Ricambi • Piezas de recambio

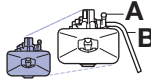

★ kein Ersatzteil
no spare part
non pièce de rechange
no ricambio
no es pieza de recambio

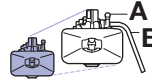
Pos		ROE	
01	RO xxxAxxxx +17	ROE 71443A	1
01	RO xxxBxxxx +17	ROE 71443B	1
02	RO xxxAxxxx	ROE 71644A	1
02	RO xxxBxxxx	ROE 71644B1	1
03		ROE 30458	1
04		ROE 47127	1
05		ROE 71697	1
06		ROE 71610	1
07		ROE 53596	1
08		ROE 53597	1





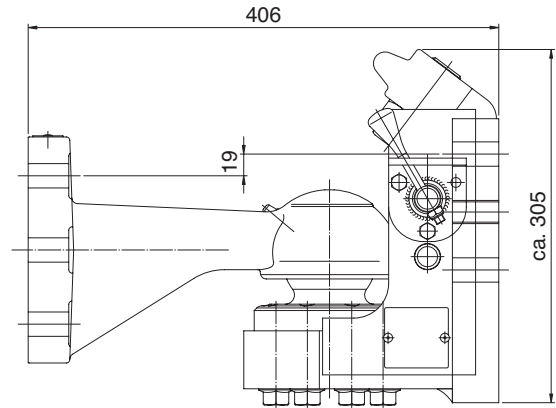
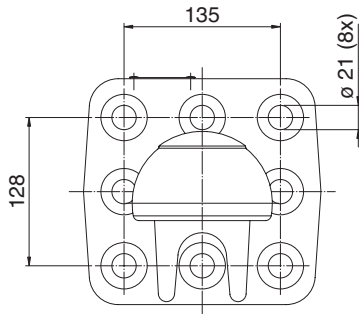
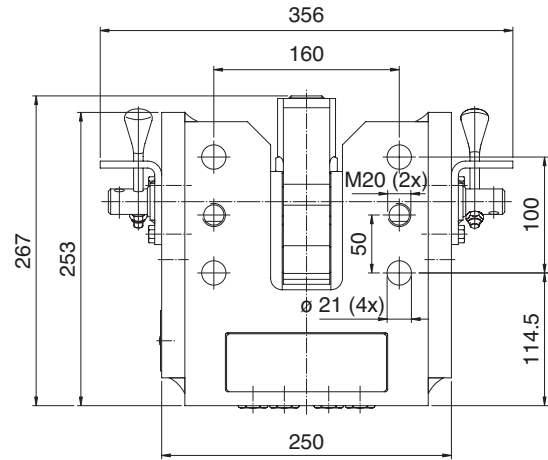

Pos		ROE	
09		ROE 46143	1
10		ROE 12642	1
11		ROE 55008	2
12		ROE 59454	1
13		ROE 71589	1
14		ROE 52568	1
15		ROE 71637	1
16		ROE 71380	1
17		ROE 52549	1

RO*908 (Typ RO*KU 80) – 80 mm

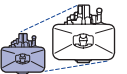
- DE** Kugelkupplungssystem 80 mm für Fahrzeugtransporter
- EN** Ball Coupling System 80 mm for Car Carrier
- FR** Système d'attelage à boule 80 mm pour plateau porte-voiture
- IT** Sistema gancio a sfera 80 mm per veicolo adibito al trasporto vetture
- ES** Sistema de enganches esféricas de 80 mm para vehículos de transporte



Technische Daten • Technical data • Données technique • Dati tecnici • Datos técnicos

 A B		 (mm)	  		 		 (kg)	ECE
			D (kN)	Dc (kN)	S (kg)	V (kN)		
RO 908H61001*	6	160 x 100	140	140	1000/2500	90/75	71,6	E1 55R-01 2833
RO 908H61501**	6	160 x 100	140	140	1000/2500	90/75	71,6	E1 55R-01 2833



* Schraubensatz 85 mm • Bolt kit 85 mm • Jeu de vis 85 mm • Kit viti 85 mm • Juego de tornillos 85 mm

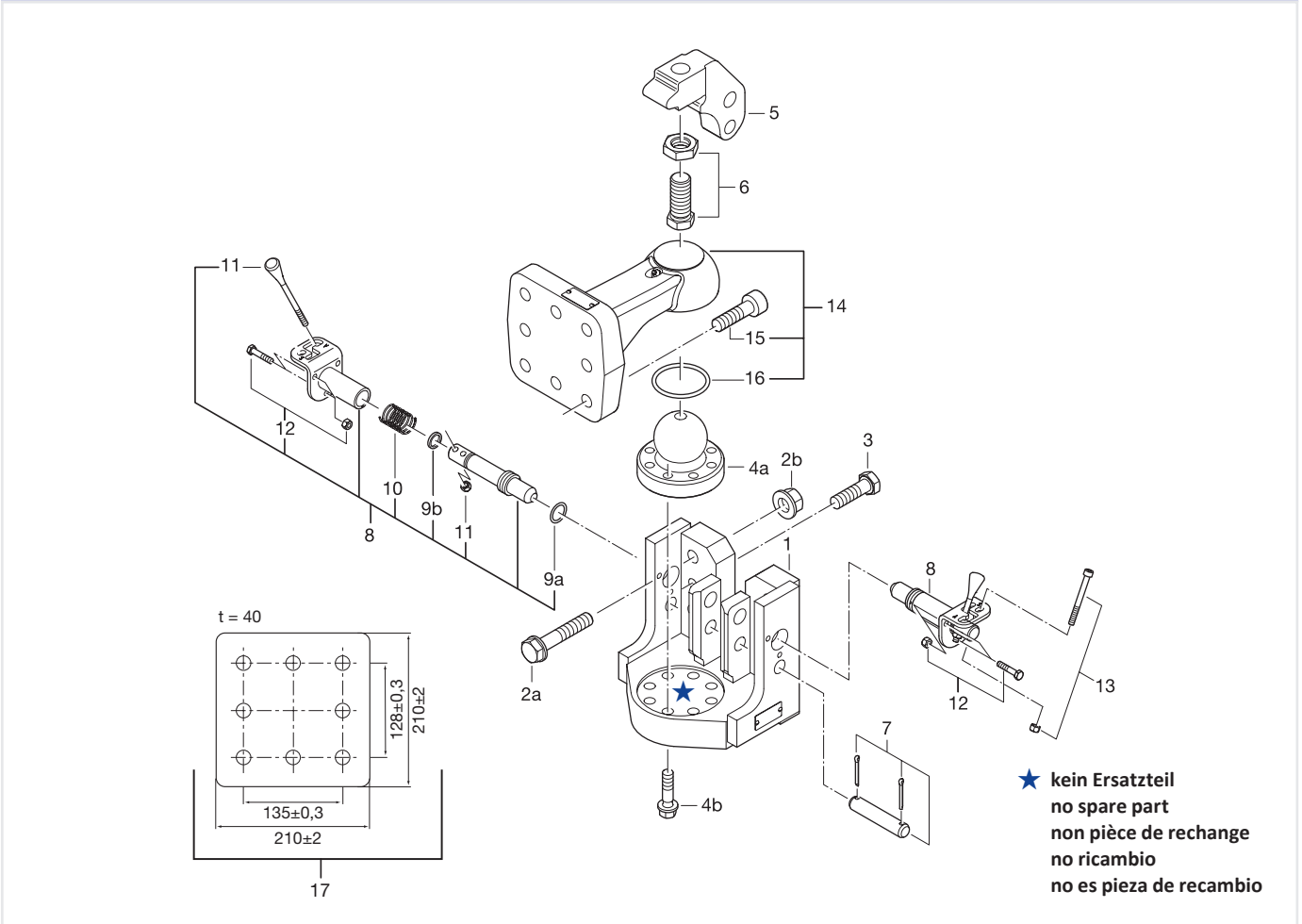

** Schraubensatz 110 mm • Bolt kit 110 mm • Jeu de vis 110 mm • Kit viti 110 mm • Juego de tornillos 110 mm

RO*908 (Typ RO*KU 80)

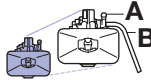
Ersatzteile • Spare parts • Pièces de rechange • Ricambi • Piezas de recambio

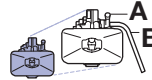

Pos		ROE	
02	2 a/b 85 mm	ROE 71687	1
02a	110 mm	ROE 30474-4	1
02b		ROE 31139-4	1
03		ROE 30133-2	1
04		ROE 71685	1
05		ROE 63002	1
06		ROE 71684	1
07		ROE 52563	1
08		ROE 71665	2
09		ROE 71683	2



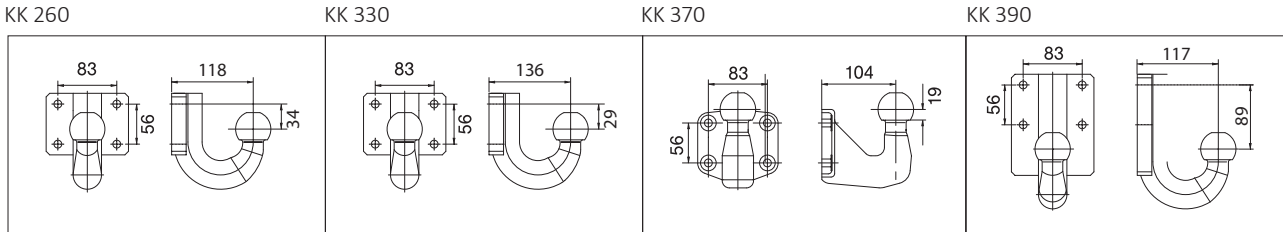
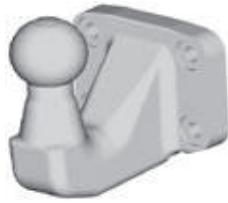

Pos		ROE	
10		ROE 55286	2
11		ROE 50283	2
12		ROE 71682	2
13		ROE 71686	2
14		ROE 57418	1
15		ROE 30485-8	1
16		ROE 25568	1
17		ROE 59455	1

50 mm – Kugel • ball • boule • sfera • bola

- DE** Kugelkupplungssystem mit Flansch
- EN** Ball hitch with flange
- FR** Attelage à boule avec platine
- IT** Gancio a sfera con flangia
- ES** Enganches esféricos con brida

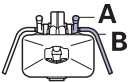

Technische Daten • Technical data • Données technique • Dati tecnici • Datos técnicos



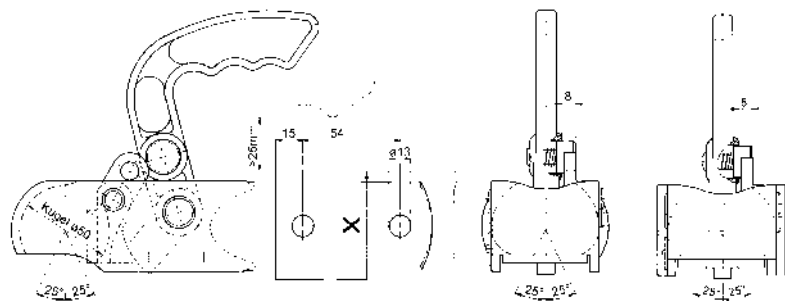
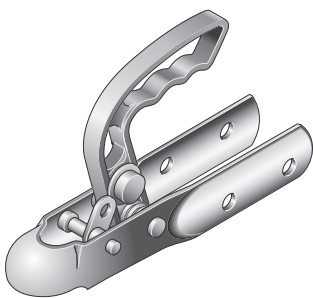

	 (mm)	 D (kN)	 S (kg)	ECE
RO KK260	83 x 56	22,5	275	E4 55R-01 0101
RO KK330	83 x 56	19,0	200	E4 55R-01 0101
RO KK370	83 x 56	27,5	300	E4 55R-01 0100
RO KK390	83 x 56	22,1	270	E4 55R-01 0099

RO★200

- DE** Zugkugelkupplung zur Verbindung mit Kupplungskugel 50 mm
- EN** Ball hitch for connecting with coupling ball 50 mm
- FR** Attelage à boule d'assemblage avec une boule d'attelage 50 mm
- IT** Gancio a sfera in combinato con un gancio a sfera 50 mm
- ES** Enganches esféricos para la conexión con una cabeza 50 mm

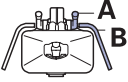

Technische Daten • Technical data • Données technique • Dati tecnici • Datos técnicos

	Typ	Deichsel • Drawbar • Flèches • Forcelle • Barras • (mm)	 S (kg)	 C (kg)	 ø (mm)	 (kg)	ABG KTA
RO 200A0050	KK 92 A	ø 70	120	1600	50	1,4	1708
RO 200B0050	KK 92 B	ø 60	120	1600	50	1,4	1708
RO 200F0050	KK 92 F	ø 60	120	1600	50	1,4	1708

RO*283 – 76 mm

- DE** Gefederte Hakenkupplung mit Sicherheitsklinkenverschluss
- EN** Hook trailer hitch with buffers and safety lock
- FR** Accouplement à crochet suspendu avec verrouillage à contrecliquet
- IT** Gancio a uncino oscillante con spinotto di sicurezza
- ES** Enganche de gancho con cierre de pestillo de seguridad

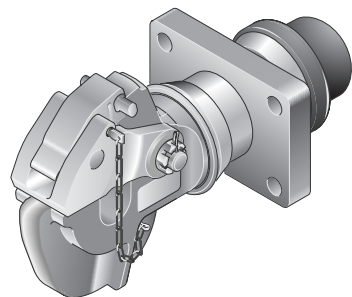

a = 76 mm
VG 74059
NATO

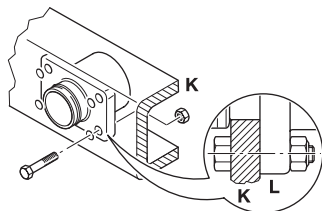
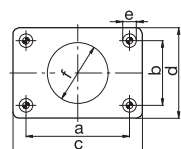
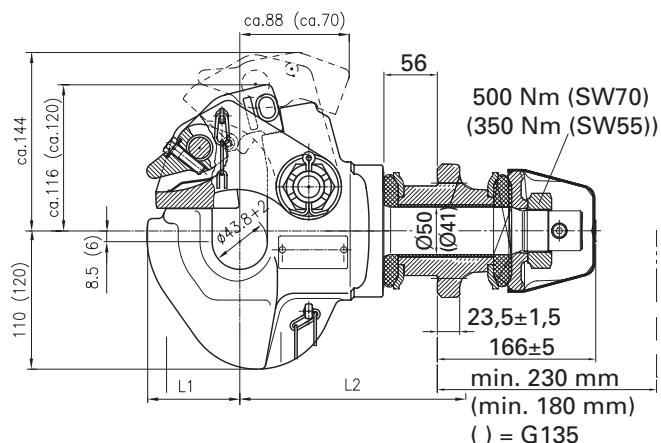
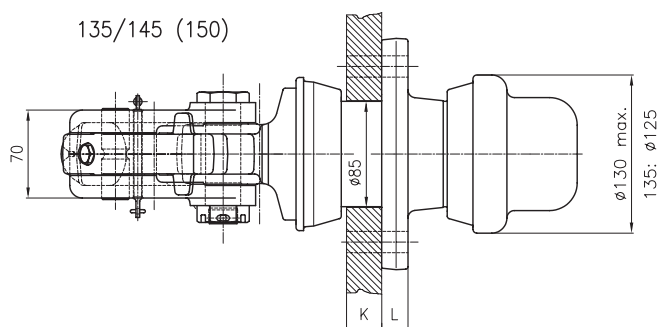

	L1 (mm)	L2 (mm)	L3 (mm)	L4 (mm)
135	74	167	131	372
145	88	180	156	410
150	88	180	156	424

	a (mm)	b (mm)	c (mm)	d (mm)	e (mm)	f (mm)
135	120,0	55,0	155,0	90,0	15,0	74,0
145	140,0	80,0	180,0	120,0	17,0	84,0
150	160,0	100,0	200,0	140,0	21,0	94,0

	K (mm)	K (mm)
135	20	20
145	28	28
150	28	28

Technische Daten • Technical data • Données technique • Dati tecnici • Datos técnicos



		(mm)	D (kN)	Dc (kN)	S (kg)	V (kN)	C (t)	R (t)	(kg)
RO 283A35002		135	70	42,5	800	15,6	6,5	16	17,7
RO 283A45002		145	95	54,0	1000	21,6	9,0	30	22,7
RO 283A50002		150	160	54,0	1500	21,6	9,0	40	31,0
RO 283A50092		150	160	54,0	1500	21,6	9,0	40	31,0

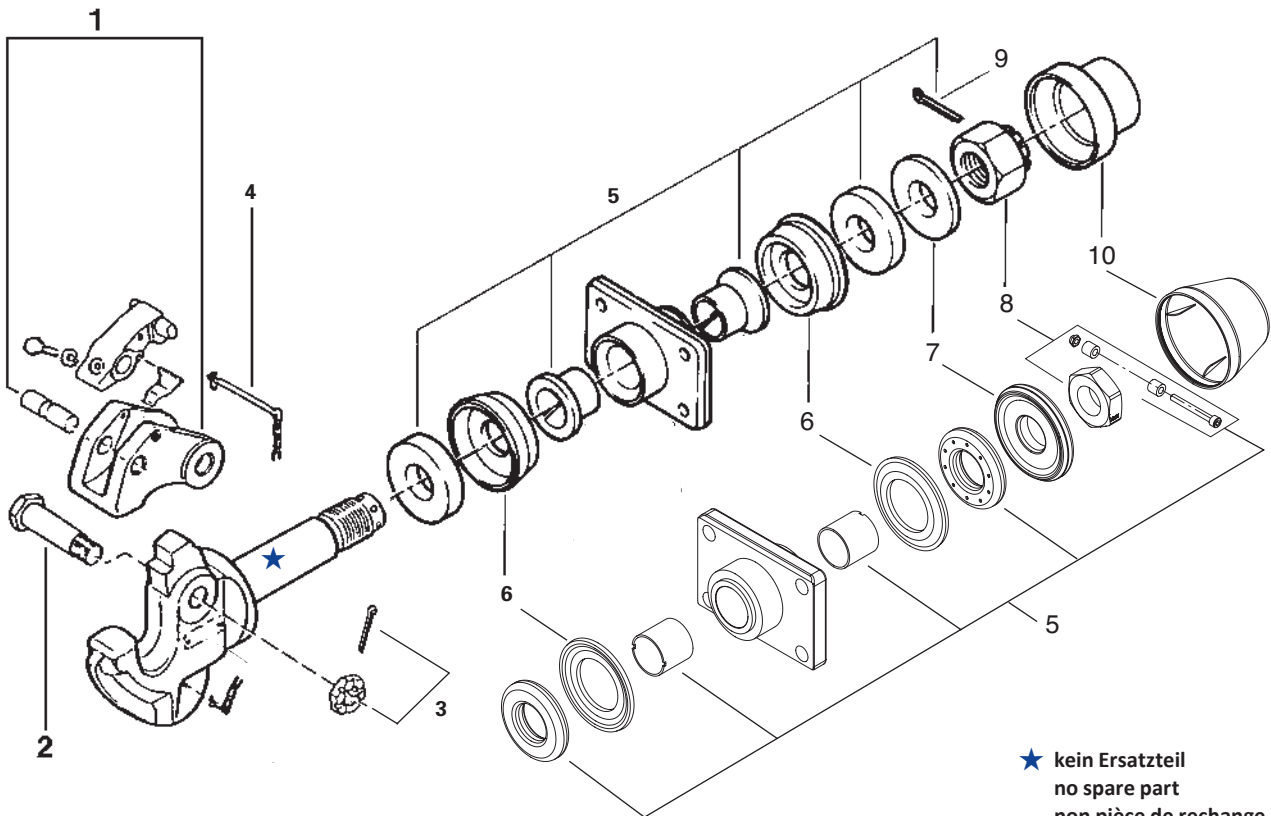

RO★283

Ersatzteile • Spare parts • Pièces de rechange • Ricambi • Piezas de recambio

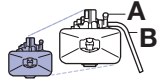

★ kein Ersatzteil
no spare part
non pièce de rechange
no ricambio
no es pieza de recambio

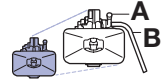
Pos		ROE	
01	135, 145	ROE 66393	1
01	150	ROE 66324	1
01	283xxxxx2	ROE 70932	1
02	135, 145	ROE 52036	1
02	283xxxxx2	ROE 52037	1
03		ROE 56030	1
04	283A35xx1	ROE 71606	1
04	283Axxxxx	ROE 70285	1
05	135	ROE 70343	1
05	283A45xx0	ROE 70344	1

Pos		ROE	
05	283A45/50xx2	ROE 70344	1
06	135	ROE 44060	2
06	145, 150	ROE 44134	2
07	283A50xx2	ROE 59280	1
08	283A45/50xx2	ROE 71796	1
09	283xxxxx2	ROE 30492	1
10	135	ROE 56051	1
10	145, 150	ROE 56049	1
10	283A45/50xx2	ROE 25347	1

RO★231 – 76 mm / 40 mm

- DE** Hakenkupplung mit Sicherheitsstecker im Verschlussbügel
- EN** Hook trailer hitch with safety lock
- FR** Accouplement à crochet avec fiche de sécurité dans l'étrier de verrouillage
- IT** Gancio a uncino con spinotto di sicurezza nella staffa di chiusura
- ES** Enganche de gancho con dispositivo de seguridad en el estribo de cierre

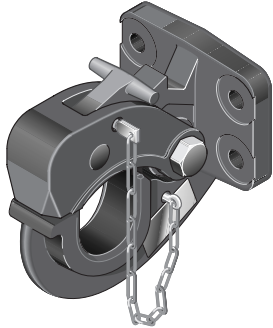





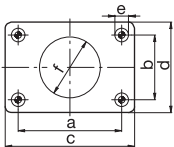
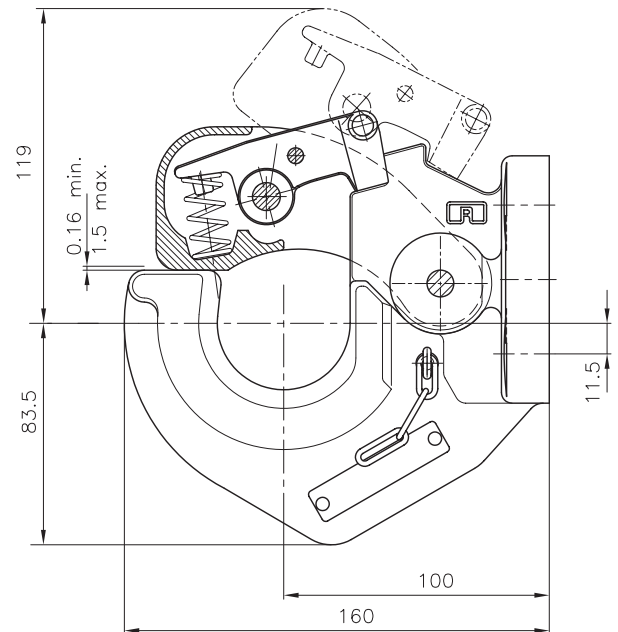
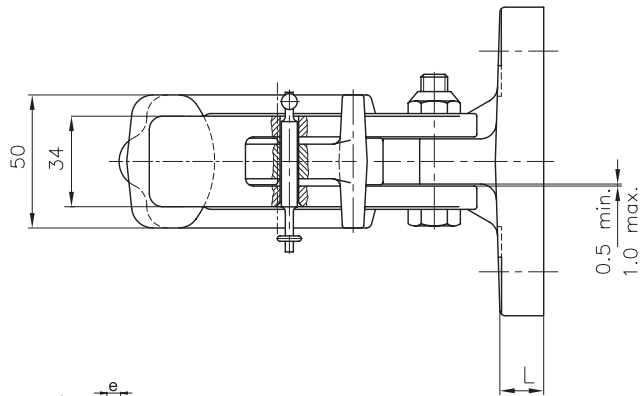

RO 231xx00x
a = 76 mm, VG 74059 NATO

RO 231xx53x
a = 40 mm, DIN 74054, 94/20/CE,
für Zugöse CH
for towing eye CH
pour anneau de remorquage CH
per occhio di traino CH
para punta de lanza CH



	a (mm)	b (mm)	c (mm)	d (mm)	e (mm)	L (mm)
05	86,0	45,0	116,0	85,0	13,0	16
11	83,0	56,0	116,0	85,0	10,5	16

Technische Daten • Technical data • Données technique • Dati tecnici • Datos técnicos



C D	A B								ECE
RO 231A05000	05	86 x 45	25	22	250	14,4		5,0	-
RO 231A05090	05	86 x 45	25	22	250	14,4		5,0	-
RO 231A05530	05	86 x 45	20	18	150	9,6		3,6	-
RO 231A05531	05	86 x 45	20	18	150	-	3,5	3,6	E1 55R-01 1958
RO 231A11000	11	83 x 56	25	22	250	14,4		5,0	-
RO 231A11530	11	83 x 56	20	18	150	9,6		3,6	-
RO 231A11531	11	83 x 56	20	18	150	-	3,5	3,6	E1 55R-01 1958

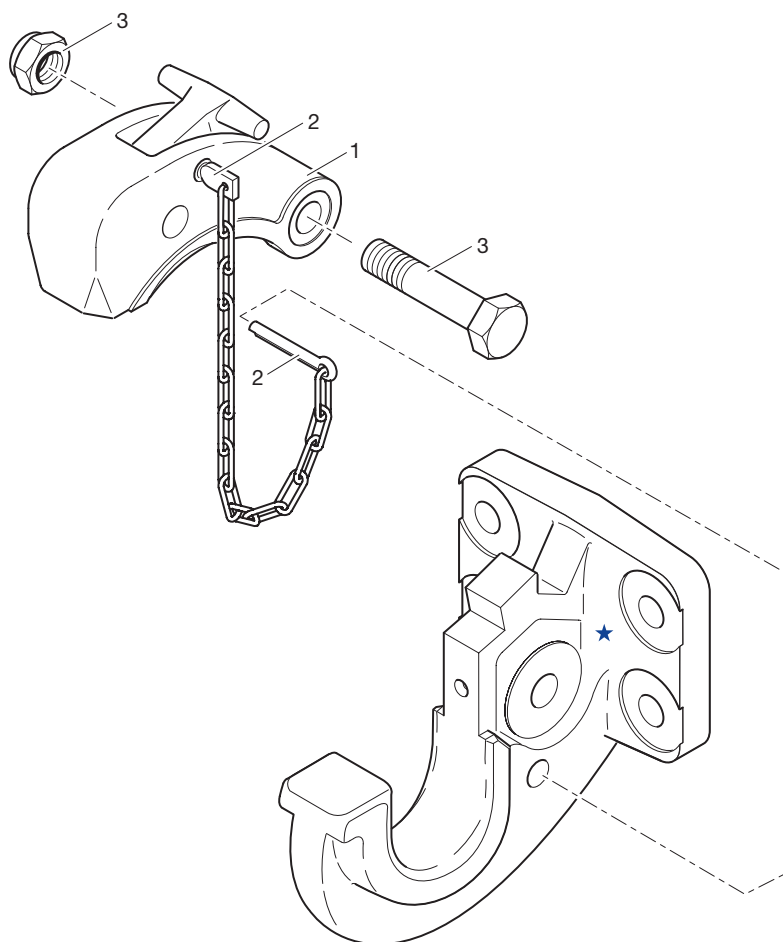

RO★231

Ersatzteile • Spare parts • Pièces de rechange • Ricambi • Piezas de recambio

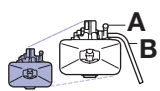

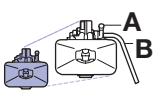

★ kein Ersatzteil
no spare part
non pièce de rechange
no ricambio
no es pieza de recambio

Pos		ROE	
01		ROE 70862	1
02		ROE 65112	1

Pos		ROE	
03		ROE 70863	1

Befestigungssätze • Mounting kits • Kits de fixation • Kit di fissaggio • Conjuntos de fijación

	ROE	
RO 231A050xx	ROE 70941	1
RO 231A0553	ROE 70949	1
RO 231A11000	ROE 70942	1
RO 231A1153	ROE 70923	1

RO★232 – 76 mm / 40 mm

- DE** Drehbare Hakenkupplung
- EN** Rotatable hook trailer hitch
- FR** Accouplement à crochet tournant
- IT** Gancio a uncino per motrici leggere
- ES** Enganche de gancho para furgonetas



a = 76 mm, VG 74059 NATO
 a = 40 mm, DIN 74054, 94/20/CE
 für Zugöse CH
 for towing eye CH
 pour anneau de remorquage CH
 per occhione di traino CH
 para punta de lanza CH

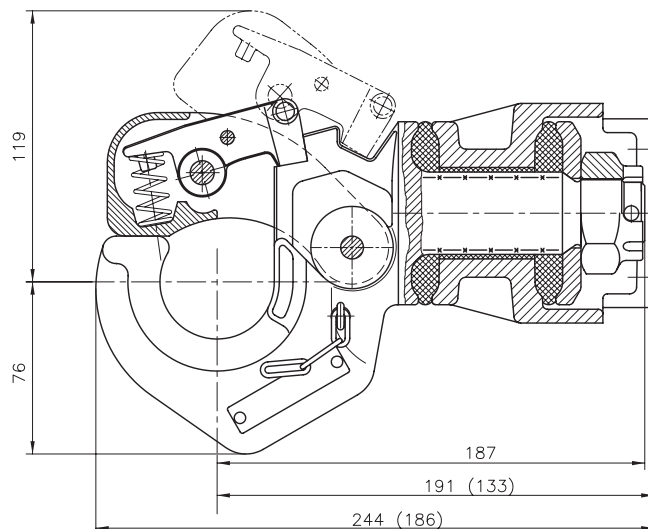
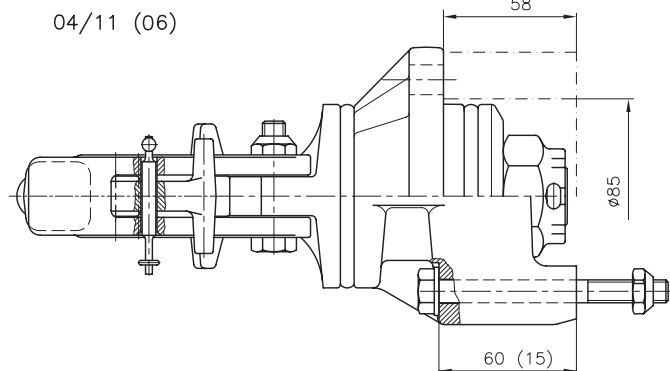

04/11 (06)

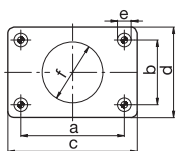

	a (mm)	b (mm)	c (mm)	d (mm)	e (mm)
04	85,0	45,0	112,0	96,0	13,0
11	83,0	56,0	112,0	96,0	10,5
06	101,6	101,6	130,0	130,0	13,0

Technische Daten • Technical data • Données technique • Dati tecnici • Datos técnicos



									e1
		(mm)	D (kN)	Dc (kN)	S (kg)	V (kN)	C (t)	(kg)	
RO 232A04531	04	85,0 x 45,0	40	22	300	14,2		7,0	
RO 232A04501	04	85,0 x 45,0	31	31	300		3,2	7,0	00-1350
RO 232A06001	06	101,6 x 101,6	40	22	300	14,2		6,7	
RO 232A06001	06	101,6 x 101,6	40	25	300	9,6		6,7	
RO 232A06531	06	101,6 x 101,6	40	22	300	14,2		6,7	
RO 232A11001	11	83,0 x 56,0	35	22	300	14,2		7,2	
RO 232A11531	11	83,0 x 56,0	35	20	250	12,0		7,2	
RO 232A11501	11	83,0 x 56,0	31	31	300		3,2	7,2	00-1353

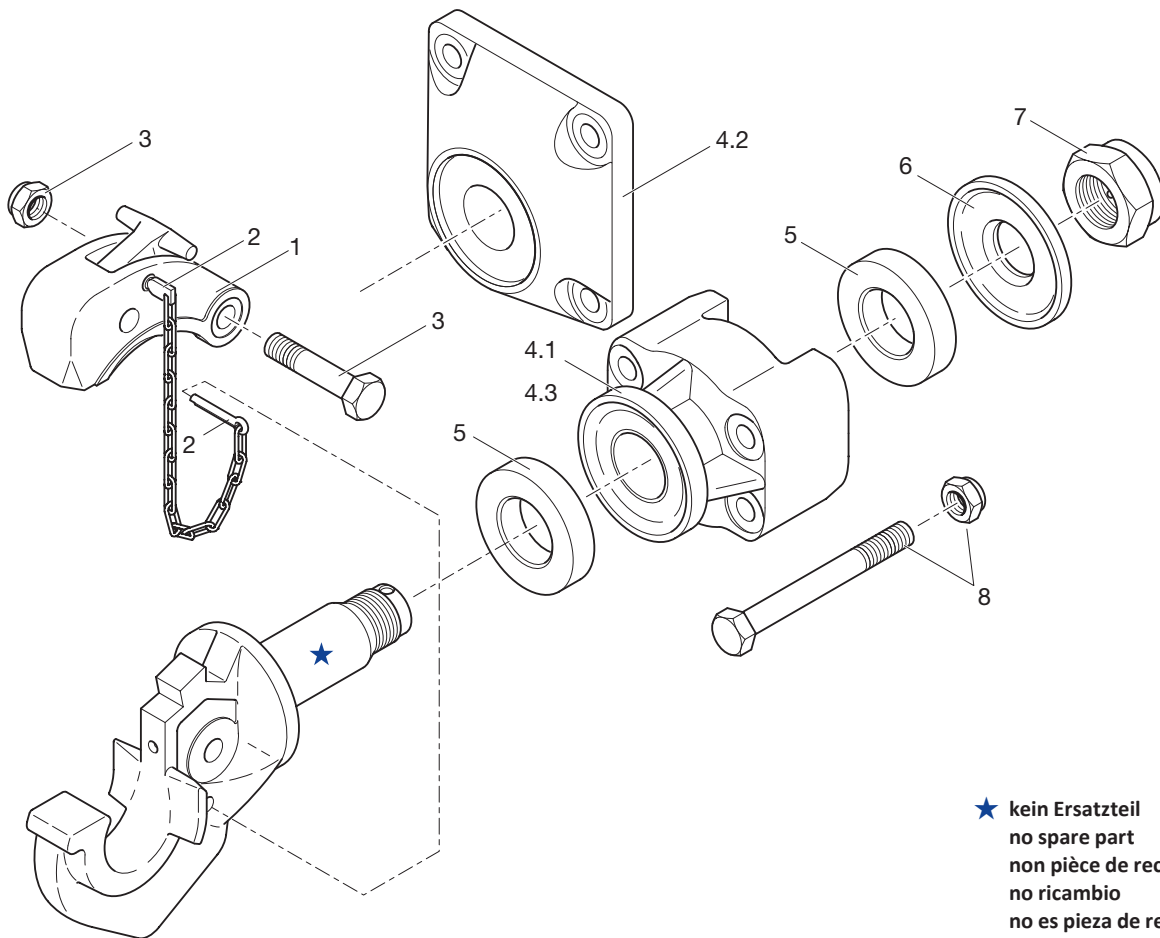

RO★232

Ersatzteile • Spare parts • Pièces de rechange • Ricambi • Piezas de recambio

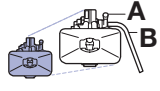

★ kein Ersatzteil
no spare part
non pièce de rechange
no ricambio
no es pieza de recambio

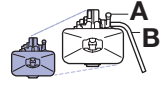
Pos		ROE	
01		ROE 70862	1
02		ROE 65112	1
03		ROE 70863	1
04.1	RO 232A04	ROE 70869	1
04.2	RO 232A06	ROE 70870	1
04.3	RO 232A11	ROE 70871	1
05		ROE 70864	1
06		ROE 59262	1

Pos		ROE	
07		ROE 56124	1
08	RO 232A0400x	ROE 70879	1
08	RO 232A0453x	ROE 70873	1
08	RO 232A0600x	ROE 70880	1
08	RO 232A0653x	ROE 70874	1
08	RO 232A1100x	ROE 70878	1
08	RO 232A1153x	ROE 70875	1

RO★205 / 207 / 230

- DE** Abschleppkupplungen
- EN** Manual towing hitches
- FR** Chapes de remorquage
- IT** Ganci di manovra
- ES** Enganches para remolcar



a = 40 mm DIN 74054, 94/20/CE
a = 50 mm DIN 74053, CE-Kl. D
a = 76 mm VG 74059 NATO

DE Amtlicher Hinweis: Abschleppkupplungen sind nicht bauartgenehmigungspflichtig. Der Verwendungszweck ist auf das Abschleppen von betriebsunfähigen Fahrzeugen und in Ausnahmefällen auf Rangierzwecke beschränkt. Die Verwendung für den **Anhängerbetrieb ist nicht gestattet.**

EN Official advice: Manual towing hitches are not obliged to be homologated. The purpose is restricted on the towing of non-usable vehicles and in exceptional cases on **purposes of switching rails.**

FR Remarque administrative : Les chapes de remorquage ne nécessitent pas d'homologation de type. L'affectation se limite au remorquage de véhicules hors d'état de rouler et, dans des cas exceptionnels, à des fins de manœuvres. L'utilisation en mode **remorque n'est pas autorisé.**

IT Avviso ufficiale: I ganci di manovra non sono soggetti ad omologazione. Vengono impiegati limitatamente allo scopo di trainare veicoli non funzionanti e in casi eccezionali anche a scopo di manovra. Non è ammesso il loro impiego per la **marcia con rimorchio.**

ES Nota oficial: Los enganches para remolcar no requieren homologación. El uso previsto está restringido a remolcar vehículos incapaces de funcionar y está limitado en casos excepcionales a fines de maniobra. El uso para el servicio con **remolque no está permitido.**

RO★205 / 207 / 230

- DE** Abschleppkupplungen
- EN** Manual towing hitches
- FR** Chapes de remorquage
- IT** Ganci di manovra
- ES** Enganches para remolcar

RO★205

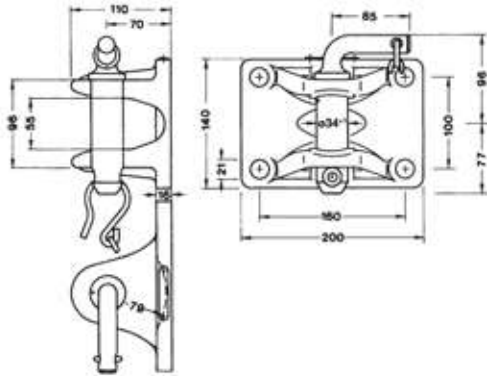



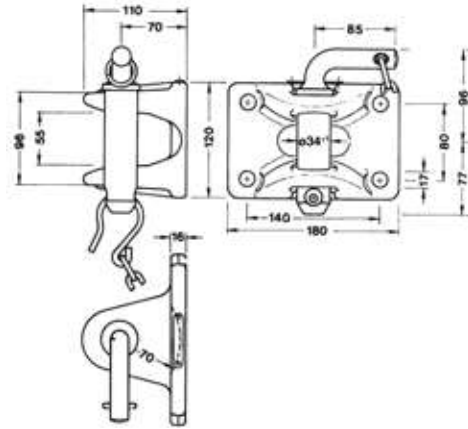

RO★207

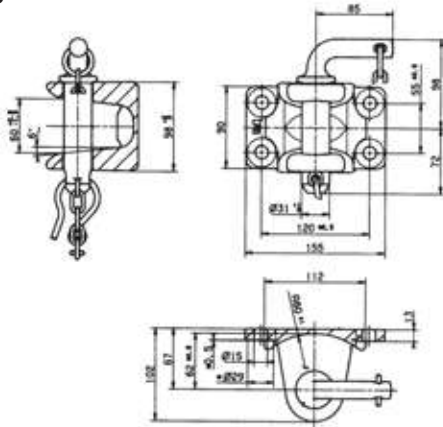

RO★230



Technische Daten • Technical data • Données technique • Dati tecnici • Datos técnicos



					EU VO Nr. 1005/2010	 (kg)
	Pos.	\varnothing (mm)	(mm)	(t)		
RO 205 A 50000	A	35	160 x 100	100,0	x	6,7
RO 205 A 51000	A	35	160 x 100	120,0	x	6,7
RO 207 A 45000	A	35	140 x 80	50,0	x	6,0
RO 230 B 35000	B	32	120 x 55	50,0	x	4,0
RO 230 C 35000	C	32	120 x 55	50,0	x	4,0
RO 230 D 35000	D	32	120 x 55	50,0	x	4,0
RO 230 E 35000	E	32	120 x 55	50,0	x	4,0
RO 230 B 35090	B	32	120 x 55	50,0	x	4,0
RO 230 F 35000	F	32	120 x 55	50,0	x	4,0

RO★205 / 207 / 230

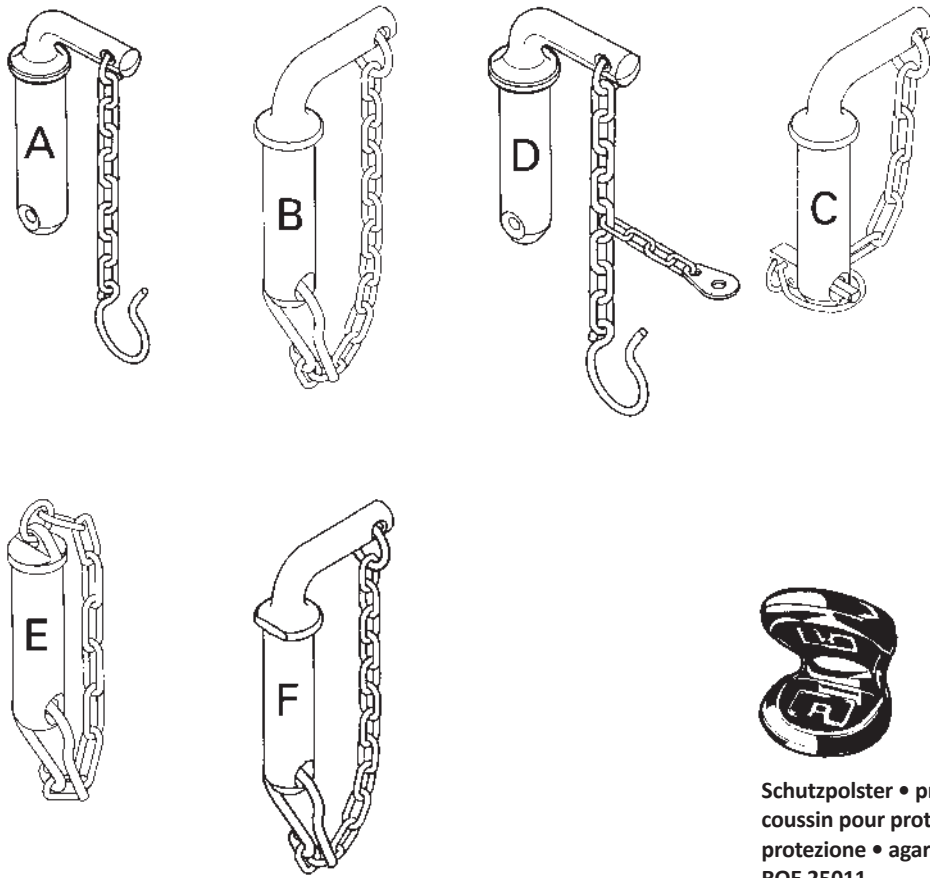
Ersatzteile • Spare parts • Pièces de rechange • Ricambi • Piezas de recambio



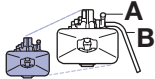



Schutzpolster • protection pad •
cousin pour protection • cuscino per
protezione • agarrador por protección
ROE 25011

	Pos.	ROE	
RO 205A50000	A	66167	58097
RO 205A51000	A	66212	58097
RO 207A45000	A	66167	58096
RO 230B35000	B	70323	58094
RO 230C35000	C	70357	58094
RO 230D35000	D	66192	58094
RO 230E35000	E	66714	58094
RO 230B35090	B	70848	58094
RO 230F35000	F	67029	58094

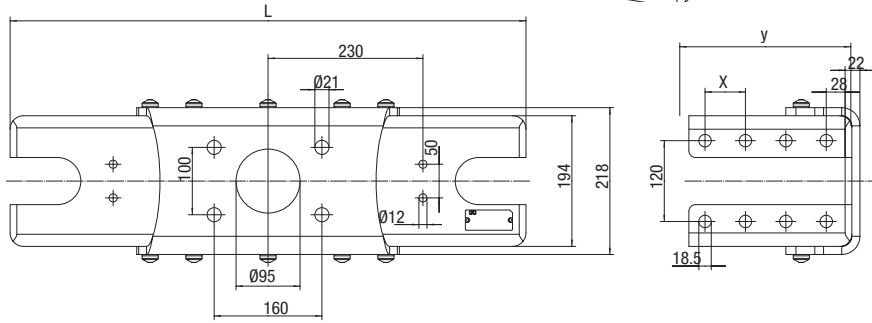
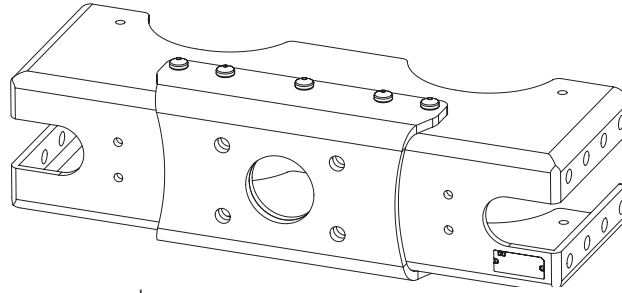
RO★CM 75-2 – Cross Member

- DE** Traverse
- EN** Traverse
- FR** Traverse
- IT** Traversa
- ES** Travesafño



Order No.		L (mm)	x	y	D (kN)				 (kg)	ECE
						Dc (kN)	S (kg)	V (kN)		
RO CM75N728A02	ROE 71579	728	60	242	200				46,4	E1 55R-01 1615
RO CM75N742A02	ROE 71579	742	60	242	200				51,7	E1 55R-01 1615
RO CM75N752A02	ROE 71579	752	60	242	200	130	1000	75	48,0	E1 55R-01 1615
RO CM75N756A02	ROE 71579	756	60	242	200				48,1	E1 55R-01 1615
RO CM75N762A02	ROE 71579	762	60	242	200				48,4	E1 55R-01 1615
RO CM75N766A02	ROE 71579	766	60	242	200				48,5	E1 55R-01 1615
RO CM75N770A02	ROE 71579	770	60	242	200	130	2000	63	48,7	E1 55R-01 1615
RO CM75N784A02	ROE 71579	784	60	242	200				49,2	E1 55R-01 1615
RO CM75N834A02	ROE 71579	834	60	242	200				51,1	E1 55R-01 1615
RO CM75N850A02	ROE 71579	850	60	242	200	144	1000	53	51,7	E1 55R-01 1615
RO CM75N834B02	ROE 71620	834	50	262	200				52,0	E1 55R-01 1615
RO CM75N822B02	ROE 71620	822	50	262	200				50,0	E1 55R-01 1615

- DE** Ausgleichbleche
- EN** Compensator sheets
- FR** Tôle de compensation
- IT** Pannelli di compensazione
- ES** Placas de compensación

Order No.	Thickness t (mm)	x (mm)	Weigth (kg)
ROE 75051	1	60	0,1
ROE 75052	2	60	0,2
ROE 75053	3	60	0,2
ROE 75054	4	60	0,3
ROE 75056	6	60	0,5
ROE 75057	8	60	0,6
ROE 75058	10	60	0,8
ROE 75135	1	50	0,1
ROE 75136	2	50	0,2
ROE 75137	5	50	0,4
ROE 75138	8	50	0,7
ROE 75139	10	50	0,8

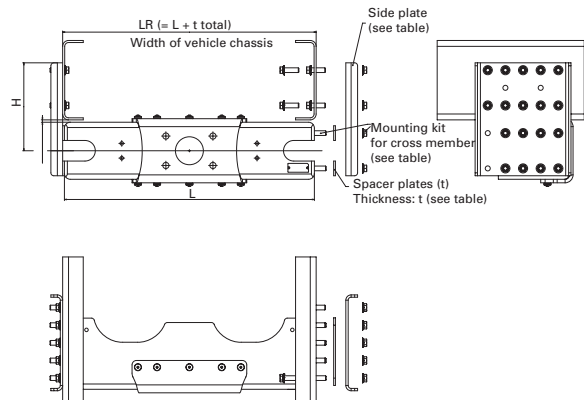

RO★CM 75-2 – Side plate

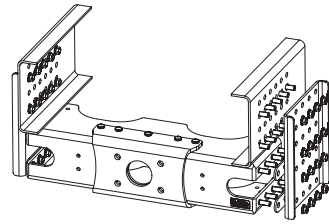
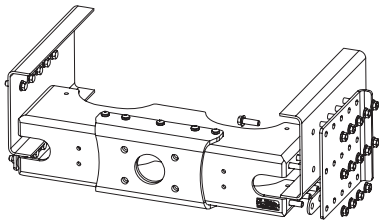

- Installation half underslung
- Assembly using SPS Compensator sheets

- Installation completely underslung
- Assembly using SPH; SPU; SPU(S); SPM; SPL; SPV; SP(MAN)

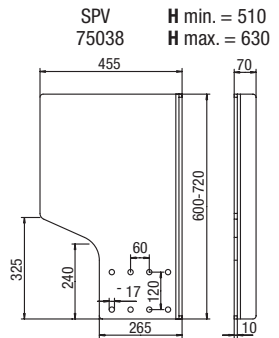
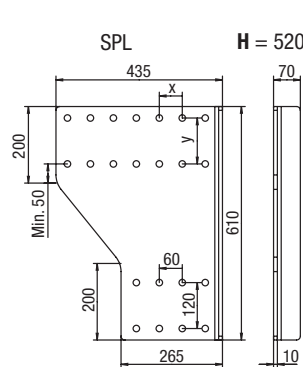
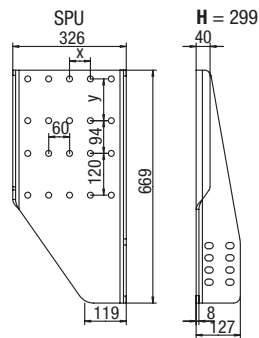
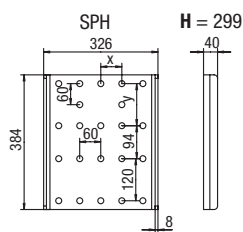
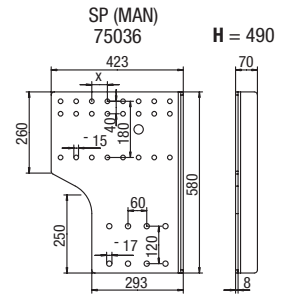
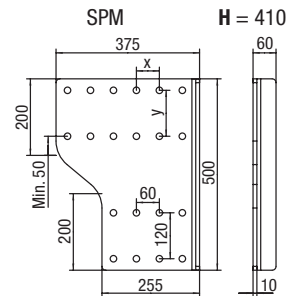
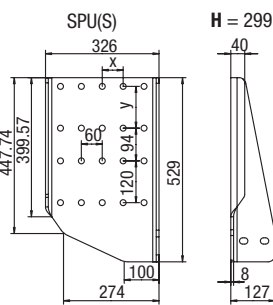
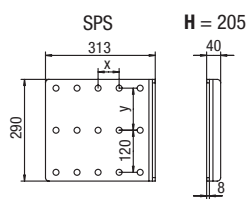

Designation	Order No.	Order No. Mounting kit	H (mm)	Weight Set (kg)	X (mm)	Y (mm)
SPS	ROE 75031	ROE 71580	205	12	60	120
SPS	ROE 75150	ROE 71892	205	10,5	50	120
SPH	ROE 75032	ROE 71620	299	17,6	60	120
SPH	ROE 75062	ROE 71621	299	17,6	50	120
SPH	ROE 75089	ROE 71621	291	17	50	100
SPH	ROE 75092	ROE 71621	341	19,2	50	150
SPU	ROE 75034	ROE 71620	299	30,6	60	120
SPU	ROE 75064	ROE 71621	341	32,6	50	120
SPU	ROE 75090	ROE 71621	291	30,3	50	100
SPU(S)	ROE 75035	ROE 71620	299	25,6	60	120
SPU(S)	ROE 75065	ROE 71621	299	25,6	50	120
SPU(S)	ROE75091	ROE 71621	341	27,4	50	50
SPM	ROE 75037	ROE 71621	410	27,6	60	120
SPM	ROE 75067	ROE 71622	410	25,4	50	120
SP(MAN)	ROE 75036	acc. MAN installation rules	490	29,5	50	s. figure
SPL	ROE 75033	ROE 71622	520	37,8	60	120
SPV	ROE 75038	ROE 71622	510 – 630	ca. 49	s. figure	s. figure

RO★100, VARIOBLOC

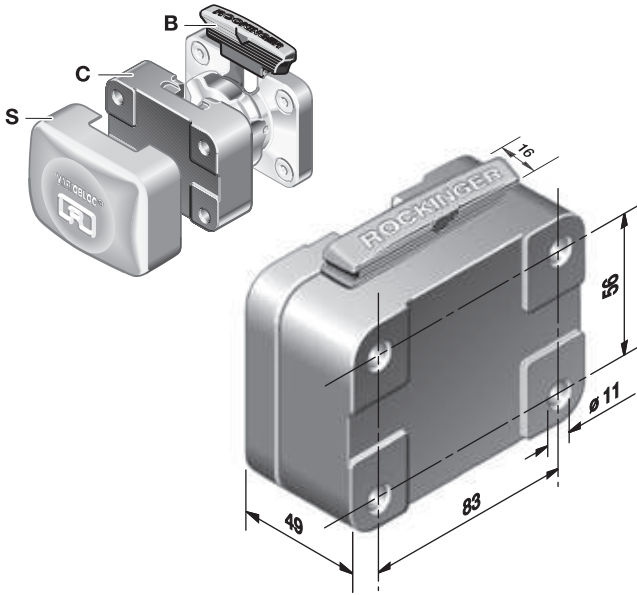





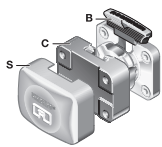

- DE** Multifunktionales Wechselsystem für Transporter, Geländewagen, Busse in Verbindung mit Bolzen-, Hakenkupplung, Kupplungskugel; geeignet für Hecktragesysteme und Arbeitsgeräte.
- EN** Multifunctional alternating system for transporter, cross-country vehicles and buses, in connection with pin hitch, hook trailer hitch, hitch ball, suitable for towbar bracket systems and work devices.
- FR** Système mobile multifonction pour véhicules utilitaires, voitures tout terrain et bus liaison avec accouplement à boulon, à crochet ou boule d'attelage ; convient pour systèmes de portage arrière et outillage.
- IT** Sistema intercambiabile multifunzione per furgoni, fuoristrada, bus in abbinamento a ganci a perno a uncino e ganci a sfera; adatto per sistemi di trasporto posteriori e attrezzi di lavoro.
- ES** Sistema de cambio multifuncional para furgonetas, vehículos todo terreno, autobuses en combinación con enganches de bulón, enganches de gancho, enganches de bola; indicado para sistemas de soporte posterior y útiles de trabajo.



Technische Daten • Technical data • Données technique • Dati tecnici • Datos técnicos



	 (mm)	 D (kN)	 Dc (kN)	 S (kg)	 V (kN)	 (kg)	ECE
ROE 100A01002*	83 x 56	30	30	250	12,0	2,7	E1 55R-01 0044
ROE 100A02002*	85 x 45	30	18	200	9,6	2,7	E1 55R-01 0044

DE * nur in Verbindung mit RO★243





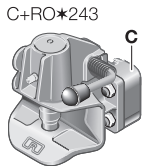

EN * only in combination with RO★243

FR * uniquement en combinaison avec RO★243





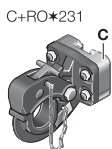

IT * solo assieme a ganci a RO★243

ES * solamente en combinación con RO★243







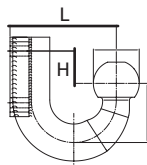
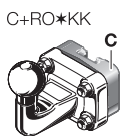

	 (mm)	 D (kN)	 Dc (kN)	 S (kg)	 V (kN)	 (kg)	ECE
Lastfall A, B Loading condition A, B							
ROE 100C01511	83 x 56	30	18	250	12,0	4,1	E1 55R-01 0031
	83 x 56	30	30	250	8,4	4,1	



	 (mm)	 D (kN)	 Dc (kN)	 S (kg)	 V (kN)	 C (t)	 (kg)	ECE
Lastfall C Loading condition C								
ROE 100C01521	83 x 56	20	18	150	-	3,5	3,3	E1 55R-01 1958



	 (mm)	 D (kN)	 S (kg)	 H (mm)	 L (mm)	 (kg)	ECE
Lastfall I, II Loading condition I, II							
ROE 100C01531*	83 x 56	22,5	275	-34	118	3,9	E1 55R-01 0101
ROE 100C01541*	83 x 56	27,5	300	19	104	3,9	E1 55R-01 0100
ROE 100C01551*	83 x 56	22,1	270	-89	117	4,2	E1 55R-01 0099
ROE 100C01561	83 x 56	19,0	200	-29	136	4,1	E1 55R-01 0101



* Bei Kombination von Basis- und Wechselpfatten unterschiedlicher Lochbildausführungen sind die jeweils kleineren Belastungswerte der Tabelle/ISO-Linien zulässig.

* Where base and interchangeable plates with different hole patterns are combined, the lower load figures in the table/ISO-Linien shall be applicable in each case.

RO★100

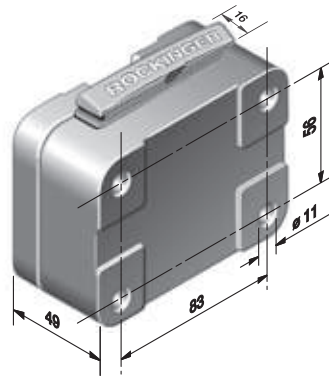
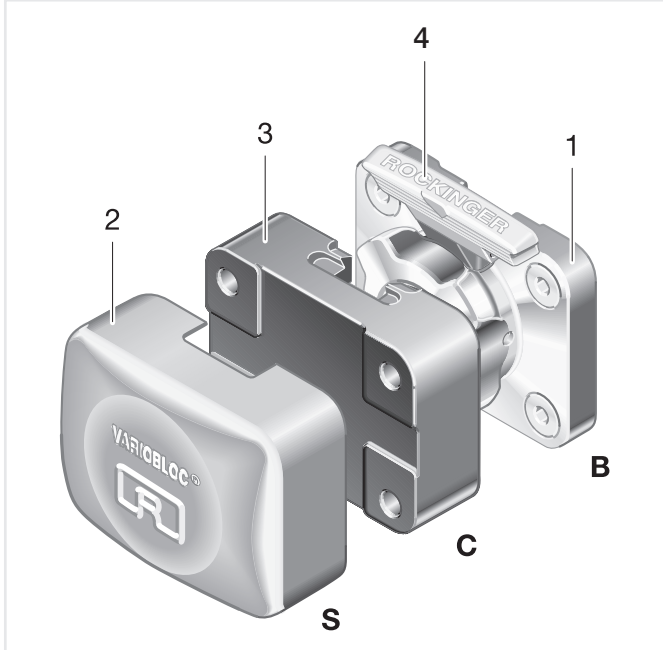
Ersatzteile • Spare parts • Pièces de rechange • Ricambi • Piezas de recambio



Pos		ROE	
01	83,0 x 56,0 mm	ROE 100B01002	1
01	85,0 x 45,0 mm	ROE 100B02002	1
02		ROE 25666	1
03	83,0 x 56,0 mm	ROE 100C01001	1
03	85,0 x 45,0 mm	ROE 100C02001	1
04		ROE 70761	1

Befestigungssätze • Screw sets • Kits de fixation • Kit di fissaggio • Juego de elementos de sujeción

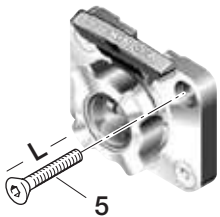

Pos	L	ROE	
05	40 mm	ROE 70759	1
05	50 mm, 30 mm	ROE 70756	1
05	55 mm	ROE 70570	1
05	60 mm	ROE 70558	1
05	110 mm	ROE 70754	1
05	130 mm, 40 mm	ROE 70805	1

Basisplatte • Base plate on the vehicle •
Plaque de base • Piastra base • Placa base

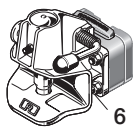

Pos	L	ROE	
06	50 mm	ROE 70755	1

Bolzenkupplung 243 auf Wechselplatte •
Pin hitch 243 on the quick-change plate •
Accouplement à boulon 243 sur plaque
mobile • Gancio a perno 243 su piastra
intercambiabile • Enganche de bulón 243
en placa intermedia

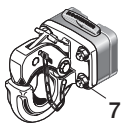

Pos	L	ROE	
07	50 mm	ROE 70755	1

Hakenkupplung 231 auf Wechselplatte •
Hook trailer hitch 231 on the quick-change
plate • Accouplement à crochet 231 sur
plaque mobile • Gancio a uncino 243 su
piastra intercambiabile • Enganche de
gancho 243 en placa intermedia

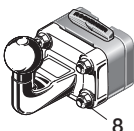

Pos	L	ROE	
08	50 mm	ROE 70755	1
08	60 mm	ROE 70757	1
08	65 mm	ROE 70758	1

Kupplungskugel auf Wechselplatte •
Hitch ball on the quick-change plate •
Boule d'attelage sur plaque mobile •
Gancio a sfera su piastra intercambiabile •
Enganche de bola en placa intermedia

RO★100, VARIOBLOC

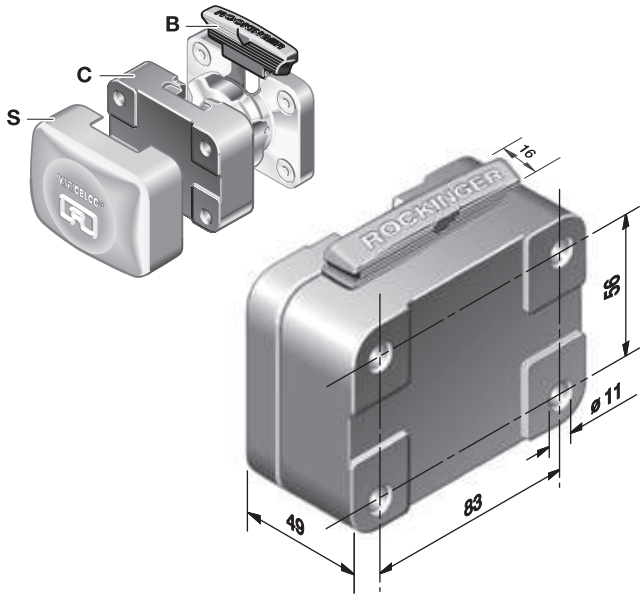

- DE** In Verbindung mit Kugelkupplungen von Fremdherstellern
- EN** In combination with ball hitches from other manufacturers
- FR** Pour les crochets à boule d'autres fabricants
- IT** Assieme a ganci a sfera di altre case produttrici
- ES** En combinación con enganches esféricos de fabricantes ajenos



ISO 85 x 45 / Y-V / Y-U / X-V

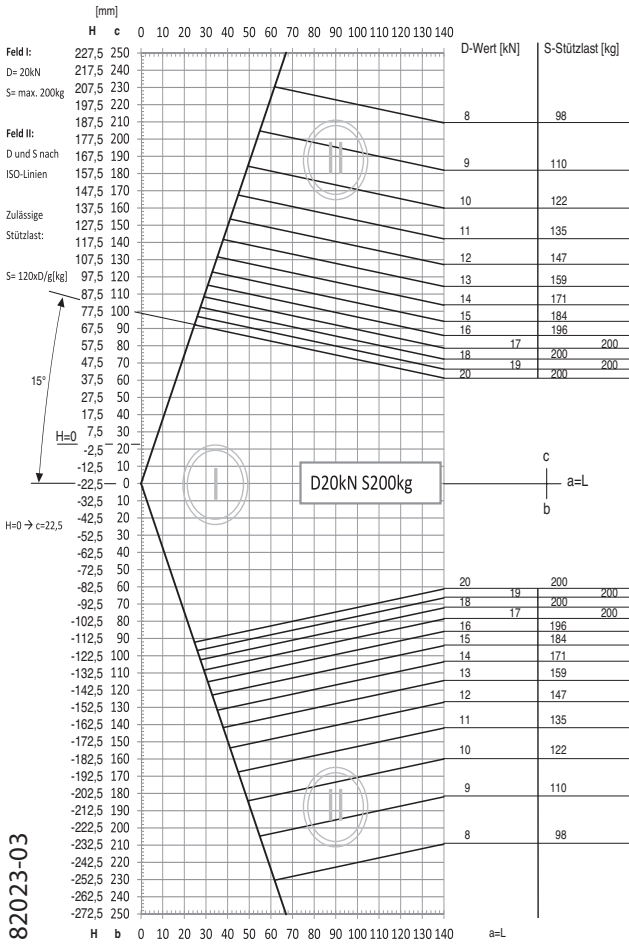

82023-03

ISO 83 x 56 / X-U

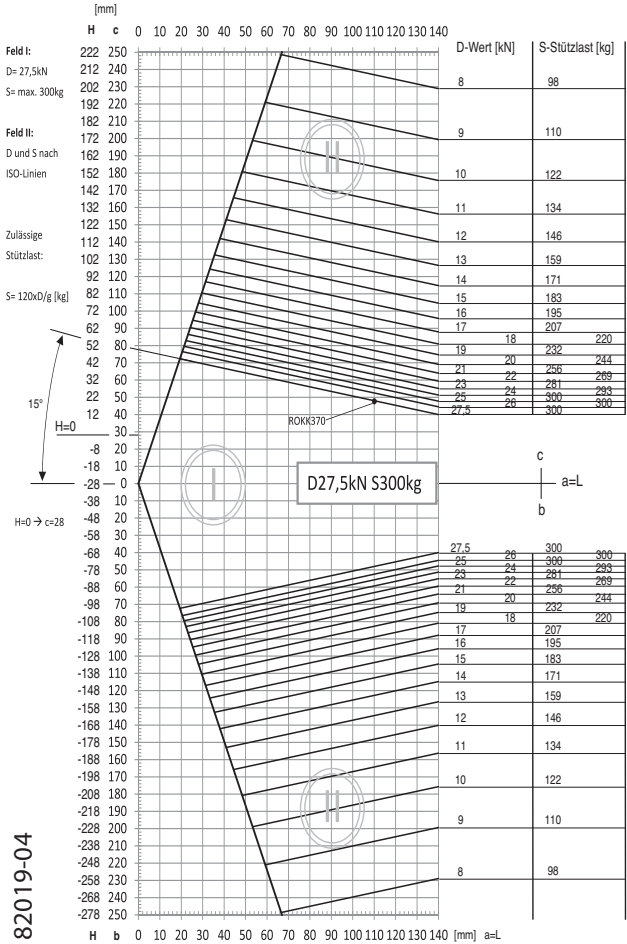

82019-04

MUB 016023 M50 (REV 01) 07-2016 (P-G)

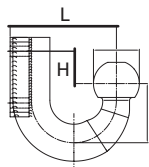

RO★480 / 483 / 580 – 40 mm / 50 mm

- DE** Selbsttätige Adapterkupplungen für 40/50 mm Zugösen und 40/50 mm Kupplungen
- EN** Automatic adapter hitches for 40/50 mm towing eyes and 40/50 mm hitches
- FR** Crochets d'adaptation automatiques pour anneaux de remorquage 40/50 mm et crochets 40/50 mm
- IT** Adattatori automatici per occhioni da 40/50 mm e ganci da 40/50 mm
- ES** Enganches adaptadores automáticos para puntas de lanza de 40/50 mm y enganches de 40/50 mm

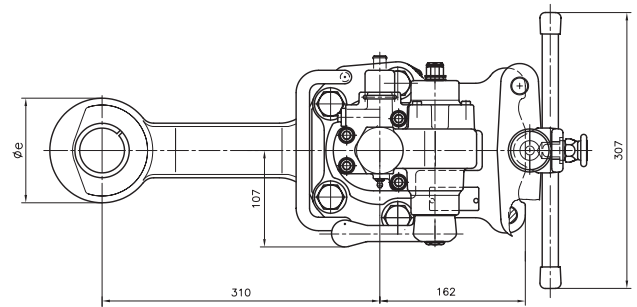
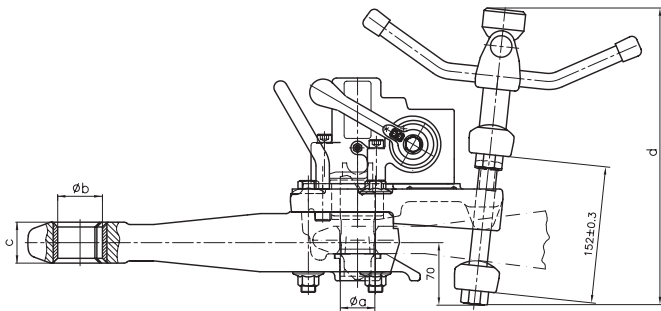

	ϕa (mm)	ϕb (mm)	c (mm)	d (mm)	ϕe (mm)
480	38,5	50,0	45,0	330,0	115,0
483	38,5	50,0	45,0	338,0	115,0
580	48,7	40,0	30,5	344,0	100,0

Technische Daten • Technical data • Données technique • Dati tecnici • Datos técnicos



							TÜV EINZEL GUTACHTEN
	A/B	D (kN)	S (kg)	50 (mm)	40 (mm)	(kg)	
ROE 480B0000	A	130	-	DIN 74052/ECE R55 Kl. C	DIN 74054/ECE R55 Kl. S	35	§22a-StVZO §13 FzTVO
ROE 483B0000	A	130	-	DIN 74052/ECE R55 Kl. C	CH	35	§22a-StVZO §13 FzTVO

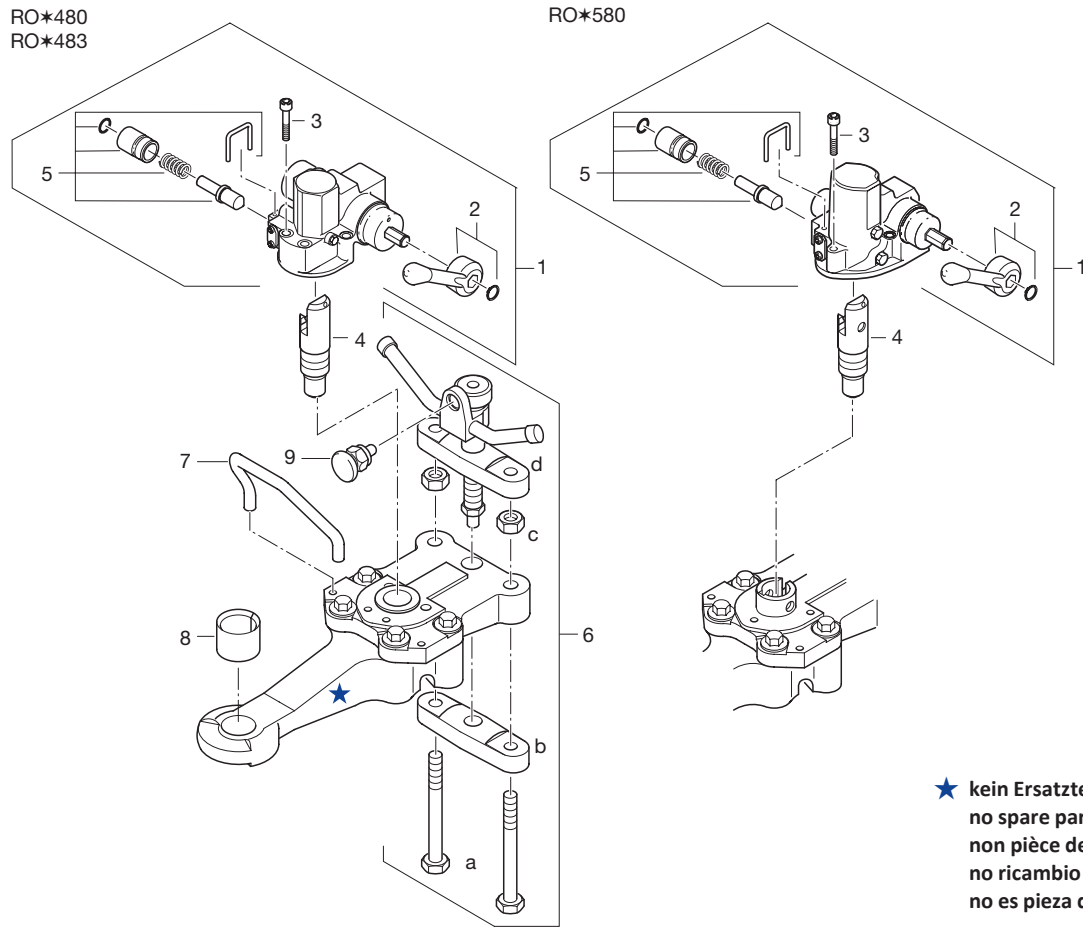

							TÜV EINZEL GUTACHTEN
	A/B	D (kN)	S (kg)	40 (mm)	50 (mm)	(kg)	
ROE 580B0000	A	130	-	DIN 74051/ECE R55 Kl. S	DIN 74053/ECE R55 Kl. D	33	§22a-StVZO §13 FzTVO

RO*480 / 483 / 580

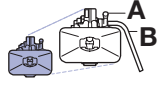
Ersatzteile • Spare parts • Pièces de rechange • Ricambi • Piezas de recambio

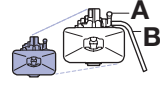

Pos		ROE	
01	480, 483	ROE 71093	1
01	580	ROE 71094	1
02		ROE 50244	1
03	480, 483	ROE 30361	1
03	580	ROE 30369	1
04	480	ROE 47111	1
04	483	ROE 47112	1
04	580	ROE 47113	1





Pos		ROE	
05		ROE 70925	1
06	a, b, c, d, 09	ROE 71095	1
07		ROE 52501	1
08	480, 483	ROE 53004	1
08	580	ROE 53051	1
09		ROE 70618	1

Reparatursatz • Repair kit • Kit de réparation • Kit riparazione • Juego de reparation

Pos.	ROE
a, b, c, d, 09	ROE 71095

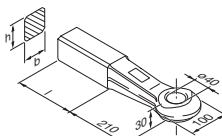



Zugösen • Towing eyes • Anneaux de remorquage • Occhioni di traino • Puntas de lanza

Form A 40 mm/50 mm mit Schweißende • Shape A 40 mm/50 mm for welding • Forme A 40 mm/50 mm avec extrémité soudée • Forma A 40 mm/50 mm con estremità saldata • Forma A 40 mm/50 mm con extremo soldado

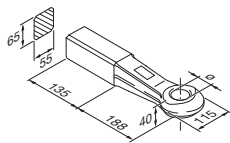
40 mm			ø (mm)	h x b (mm)	l (mm)						ECE	
						D (kN)	Dc (kN)	S (kg)	V (kN)			(kg)
			ROE 57260	40	40 x 40	110	18	18	180	8	4,1	E1 55R-01 2545
			ROE 57262	40	50 x 40	110	25	25	250	9	4,7	E1 55R-01 2544
			ROE 57264	40	50 x 50	110	70	50	500	14	5,9	E1 55R-01 2543
			ROE 57268	40	65 x 55	125	125	66	900	20	7,8	E1 55R-01 2541
			ROE 57270	40	65 x 60	125	125	74	1000	23	8,2	E1 55R-01 2540
			ROE 57374	40	65 x 57	125	125	42,4	250	12	5,0	E1 55R-01 2481
			ROE 57272	50	65 x 60	170	190	90	1000	30	11,4	E1 55R-01 2561



Form A mit Schweißende nur für Schweizer Kupplungen • Shape A for welding only for Swiss hitches • Forme A avec extrémité soudée uniquement pour crochets suisses • Forma A con estremità saldata solo per ganci svizzeri • Forma A con extremo soldado sólo para enganches suizos



	ø (mm)		D (kN)		Dc (kN)				ECE
						S (kg)	V (kN)		
	ROE 57229	40	168	66	900	20,0	8,7	E1 55R-01 2562	

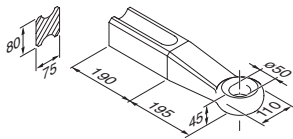



Schwerlastzugöse mit Schweißende 50 mm • Heavy duty towing eye for welding 50 mm • Anneaux de remorquage pour lourdes charges avec extrémité soudée 50 mm • Occhiono per traini eccezionali con estremità saldata 50 mm • Punta de lanza para cargas pesadas con extremo soldado 50 mm

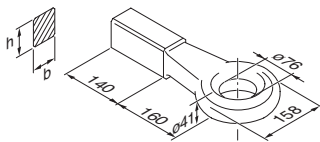

	D (kN)		ECE





Ringzugöse mit Schweißende 76 mm VG 74059 • Ring towing eye for welding 76 mm VG 74059 • Anneaux de remorquage avec extrémité soudée 76 mm VG 74059 • Occhio torici con estremità saldata 76 mm VG 74059 • Punta de lanza anulares con extremo soldado 76 mm VG 74059

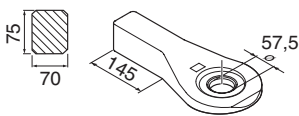

	h x b (mm)		D (kN)	S (kg)		C ¹ (t)		(kg)



Zugöse 57,5 mm • Towing eye 57,5 mm • Anneaux de remorquage de 57,5 mm • Occhio di traino 57,5 mm • Punta de lanza 57,5 mm

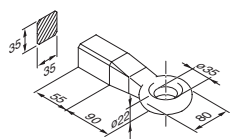

			D (kN)	Dc (kN)	S (kg)	V (kN)		(kg)	ECE

Zugöse für Flurförderzeuge mit Schweißende 35 mm • Towing eye for industrial trucks for welding 35 mm • Anneaux de remorquage pour chariots de manutention avec extrémité soudée 35 mm • Occhio per veicoli trasporti interni con estremità saldata 35 mm • Punta de lanza para vehículos industriales con extremo soldado 35 mm



		R (t)	S (kg)		(kg)

Schwerlastzugöse mit Schweißende 90 mm • Heavy duty towing eye for welding 90 mm • Anneaux de remorquage avec extrémité soudée 90 mm • Occhio torici con estremità saldata 90 mm • Punta de lanza anulares con extremo soldado 90 mm

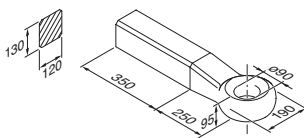

		R (t)		(kg)

Prüflehren • Wear gauges • Calibres de contrôle • Calibri • Patrones de comprobación

- DE** Kupplungsbolzen und Zugöse
- EN** Hitch pin and towing eye
- FR** Boulon d'accouplement et anneau de remorquage
- IT** Perno di traino e occhione
- ES** Pernos de acoplamiento y punta de lanza



(mm)		ROE
30 (LoF), 40		ROE 57026
50 (ISO)		ROE 57122
57	RO 57/57 flex	ROE 71354

- Untere Buchse • Lower bush • Coussinet inférieur • Bussola inferiore • Casquillo inferior

(mm)		ROE
40		ROE 57290
50	(RO 700, RO 710, RO 715)	ROE 57277
50	(RO 500, RO 530, RO 560)	ROE 57334
57,5	(RO 57/57 flex)	ROE 71354

Werkzeuge • Tools • Outils • Attrezzi • Herramientas

- DE** Montagedorn zum Ein- und Ausschlagen von Zugösenbuchsen
- EN** Mounting tool for hammering in and removing bushes
- FR** Outil enrouleur pour coussinets d'anneaux de remorquage
- IT** Mandrino di montaggio per infilare e sfilare le bussole degli occhioni
- ES** Punzón de montaje para insertar y sacar los casquillos de las puntas de lanza



ø (mm)	ROE
40	ROE 57111
50	ROE 57228

- DE** Einroll-Werkzeug für geschlitzte Zugösenbuchsen
- EN** Rolling-in-device for bushes
- FR** Outil enrouleur pour coussinets d'anneaux de remorquage
- IT** Utensile per profilare a rullo le bussole degli occhioni
- ES** Herramienta de arrollar para casquillos de punta de lanza

ø (mm)	ROE
40	ROE 57059
50	ROE 57088

- DE** Werkzeugkoffer
- EN** Tool Box
- FR** Boîte à outils
- IT** Maletín de herramientas
- ES** Valigia utensili



	ROE
RO 57/57flex	ROE 71275
ROE 57370/ROE 57371/ROE 57386/ROE 57384	ROE 57397

Aufrüstsätze • Upgrade kits • Kits d'équipement • Kit complementari • Juegos de equipamiento posterior

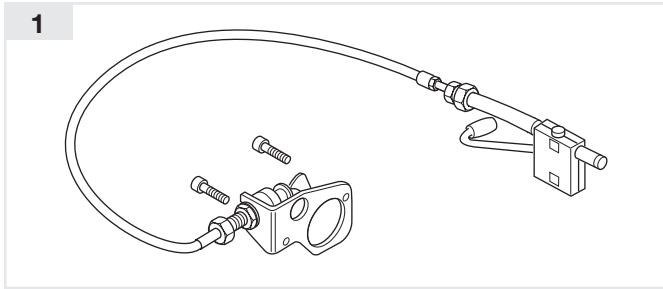

Mechanische Fernbedienung (40, 50 mm) (RC-MS) • Mechanical remote control (40, 50 mm) (RC-MS) • Commande à distance mécanique (40, 50 mm) (RC-MS) • Apertura meccanica a distanza (40, 50 mm) (RC-MS) • Telemando mecánico (40, 50 mm) (RC-MS)

ROE	
ROE 70962	bis/up to/jusqu'à/fin a/hasta RO 500xxx3, RO 400xxxC, RO 430xxxC, RO 500xxx3, RO 530xxxC, RO 560xxxC, RO 570, RO 576
ROE 71676	für/for/pour/per/para RO 400xxx1 ab/from/de/da/de RO 430xxx2, RO 500x66xx0, RO 510xxx0

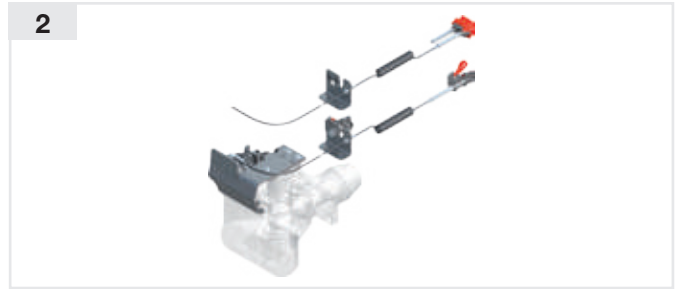

Pneumatische Fernbedienung – öffnen (RC-PL-2.0) • Pneumatic remote operation – opening (RC-PL-2.0) • Commandes pneumatiques à distances – ouverture (RC-PL-2.0) • Comando a distanza pneumatico – aprire (RC-PL-2.0) • El mando a distancia neumático – abrir (RC-PL-2.0)

ROE	
ROE 71909-P	für/for/pour/per/para RO 500x66xx0 und/and/et/e/y RO 510x61xx0 mit/with/avec/con/con Palm Stecker
ROE 71909-D	für/for/pour/per/para RO 500x66xx0 und/and/et/e/y RO 510x61xx0 mit/with/avec/con/con Duomatic-Stecker

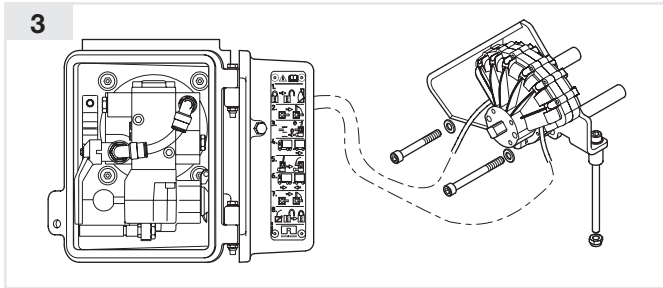

Pneumatische Fernbedienung – öffnen und schließen (RC-PC) • Pneumatic remote operation – opening and closing (RC-PC) • Commandes pneumatiques à distances – ouverture et fermeture (RC-PC) • Comando a distanza pneumatico – aprire e chiudere (RC-PC) • El mando a distancia neumático – abrir y cerrar (RC-PC)

ROE	
ROE 71270	bis/up to/jusqu'à/fin a/hasta RO 500xxx3, RO 530xxx, RO 560xxx
ROE 71461	für/for/pour/per/para RO 400xxx1, RO 430xxx2
ROE 71459	für/for/pour/per/para RO 410xxx0, RO 413 ab/from/de/da/de
ROE 71645	für/for/pour/per/para RO 590xxx1
ROE 71677	für/for/pour/per/para RO 500x66xxx
ROE 71167	für/for/pour/per/para RO 570xx, RO 576xxx
ROE 71594	für/for/pour/per/para RO 510x61xxx

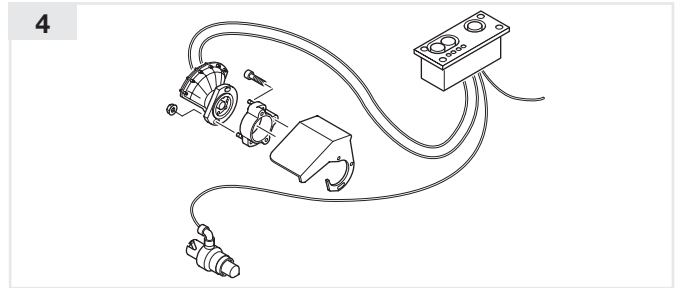

Elektropneumatische Fernbedienung – Kabine (RC-PCC) • Electropneumatic remote operation – Cabin (RC-PCC) • Commande à distance électropneumatique – Cabine (RC-PCC) • Apertura elettropneumatica a distanza – cabina (RC-PCC) • Telemando electroneumático – cabina (RC-PCC)

ROE	
ROE 70844C	bis/up to/jusqu'à/fin a/hasta RO 400xxxC, RO 430xxxC, RO 500xxx3, RO 530xxx, RO 560xxx

Aufrüstsätze • Upgrade kits • Kits d'équipement • Kit complementari • Juegos de equipamiento posterior



Elektrische Fernanzeige, Anzeige am Heck (RI-BR) • In-cab status indicator, display at the rear (RI-BR) • Affichage à distance électrique, affichage à l'arrière (RI-BR) • Segnalatore elettronico, segnalatore posteriore (RI-BR) • Teleindicación eléctrica, monitor en la parte trasera (RI-BR)

ROE	
ROE 71701	für/for/pour/per/para RO 400xxx1, RO 410xxx0, ab/from/de/da/de RO 413xx0, RO 430xxx2, RO 500x66xx0, RO 510xxx0, RO 590xxx1



Elektrische Fernanzeige, Anzeige in der Kabine (RI-BC) • In-cab status indicator, display in the cab (RI-BC) • Affichage à distance électrique, affichage en cabine (RI-BC) • Segnalatore elettronico, segnalatore nella cabina (RI-BC) • Teleindicación eléctrica, monitor en la cabina (RI-BC)

ROE	
ROE 70936	bis/up to/jusqu'à/fin a/hasta RO 400xxxC, RO 430xxxC, RO 500, RO 530xxxC, RO 560xxxC
ROE 71654	für/for/pour/per/para RO 400xxx1, RO 410xxx0, ab/from/de/da/de RO 413xx0, RO 430xxx2, RO 500x66xx0, RO 510xxx0, RO 567xxx0, RO 590xxx1



Elektronische Fernanzeige (zwei Sensor) (RI-E) • Electronically in-cab status indicator (2-sensor) (RI-E) • Affichage à distance électronique (2 capteurs) (RI-E) • Segnalatore apertura/chiusura elettronico (2 sensori) (RI-E) • Teleindicación electrónico (2 sensores) (RI-E)

ROE	
ROE 71546	für/for/pour/per/para RO 400xxx1, RO 410xxx0, ab/from/de/da/de RO 413xx0, RO 430xxx2, RO 500x66xx0, RO 510xxx0, RO 567xxx0, RO 590xxx1



Schwenkwinkel-Warnanzeige (50 mm) (RI-ETW) • Drawbar turn angle warning system (50 mm) (RI-ETW) • Voyant d'angle de rotation (50 mm) (RI-ETW) • Indicazione di pericolo angolo di inclinazione (50 mm) (RI-ETW) • Indicador de advertencia de ángulo de giro (50 mm) (RI-ETW)

ROE	
ROE 71547*	ab/from/de/da/de RO 510xxx0, RO 500x66xx0

* 3 Sensor Lösung inkl. elektronische Fernanzeige (8) • 3 sensor solution including in-cab status indicator (8) • Solution à 3 capteurs, affichage à distance électronique inclu (8) • Soluzione a 3 sensori con segnalatore elettronico (8) • Solución de 3 sensores incl. teleindicación eléctrica (8)

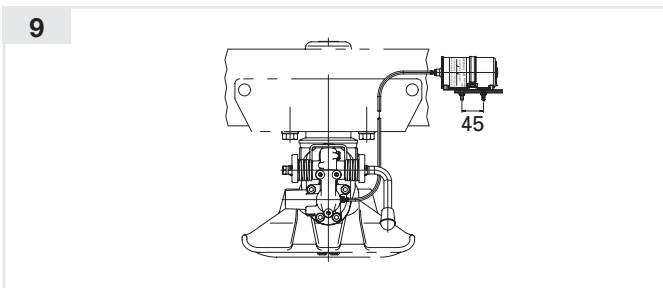

LubeTronic AK1 mit einer Schmierstelle • LubeTronic AK1 with one lubricating point • LubeTronic AK1 avec un point de graissage • LubeTronic AK1 con un punto di lubrificazione • LubeTronic AK1 con un punto de engrase

ROE	
ROE 71624-1	für/for/pour/per/para RO 400, RO 410, RO 413, RO 430, RO 500, RO 510, RO 530, RO 560, RO 590, RO 50E, RO 50

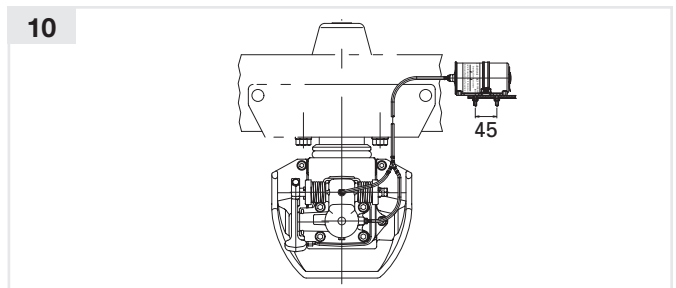

LubeTronic AK2 mit zwei Schmierstellen • LubeTronic AK2 with two lubricating points • LubeTronic AK2 avec deux points de graissage • LubeTronic AK2 con due punti di lubrificazione • LubeTronic AK2 con dos puntos de engrase

ROE	
ROE 71624-2	für/for/pour/per/para RO 570, RO 576



Aufrüstsätze • Upgrade kits • Kits d'équipement • Kit complementari • Juegos de equipamiento posterior

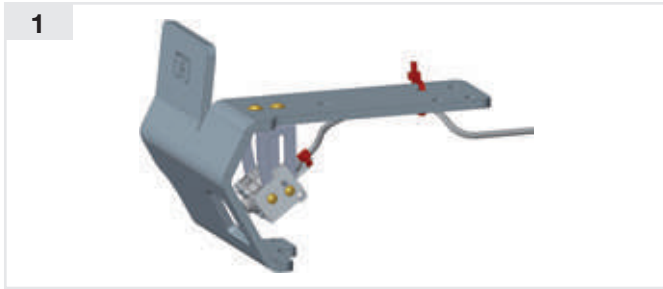

für einfache pneumatische Fernbetätigung (RC-PL-2.0) • for standard pneumatic remote control (RC-PL-2.0) • pour commandes pneumatiques à distances standard (RC-PL-2.0) • per standard comando a distanza pneumatico (RC-PL-2.0) • para telemando neumático estándar (RC-PL-2.0)

ROE	
ROE 71946	für/for/pour/per/para RO 50/50 E mit/with/avec/con/con RC-PL-2.0



für pneumatische Fernbetätigung kraftöffnend/schließend (RC-PC) • for pneumatic remote operation powered opening/closing (RC-PC) • pour commandes pneumatiques à ouverture et fermeture par pression (RC-PC) • por comando a distancia pneumatico forzare l'apertura/chiusura (RC-PC) • para el mando a distancia neumático forzar apertura/cierre (RC-PC)

ROE	
ROE 71947	für/for/pour/per/para RO 50 mit/with/avec/con/con RC-PC



für pneumatische Fernbetätigung kraftöffnend/schließend (RC-PC) • for pneumatic remote operation powered opening/closing (RC-PC) • pour commandes pneumatiques à ouverture et fermeture par pression (RC-PC) • por comando a distancia pneumatico forzare l'apertura/chiusura (RC-PC) • para el mando a distancia neumático forzar apertura/cierre (RC-PC)

ROE	
ROE 71948	für/for/pour/per/para RO 50 E mit/with/avec/con/con RC-PC



für pneumatische Fernbetätigung kraftöffnend/schließend (RC-PC) • for powered remote operation force opening/closing (RC-PC) • pour commandes pneumatiques à ouverture et fermeture par pression (RC-PC) • por comando a distancia pneumatico forzare l'apertura/chiusura (RC-PC) • para el mando a distancia neumático forzar apertura/cierre (RC-PC)

ROE	
ROE 71949	für/for/pour/per/para RO 50 BNA mit/with/avec/con/con RC-PC



Monitor • Display • Moniteur • Schermo • Monitor



ROE	
ROE 90521	ROCKINGER Monitor/display/afficher/schermo/monitor



Verlängerungskabel • Extension cable • Rallonge • Prolunga • Cable de extensión

ROE	
ROE 90515	für ROCKINGER Monitor/display/afficher/schermo/monitor

Für fahrzeugeigene Monitorsysteme • For in-vehicle monitor systems • Pour les systèmes de surveillance embarqués • Per sistemi di monitoraggio a bordo del veicolo • Para sistemas de monitorización en vehículos

Hersteller / Manufacturer / Fabricant / Produttore / Fabricante	Typ/System / Type/System / Type/ Système/ Tipo/Sistema / Tipo/Sistema	Vorrüstung / Preparati- on / Préparation / Prepara- zione / Preparación	Verlängerungskabel / Extension cable / Câble d'extension / Prolunga / Cable de extensión  ROE	Adapter / Adapter / Adaptateur / Adattatore / Adaptador  ROE
MAN	TG 2 mit/with/avec/con/con MMT2-Advanced-Navi	351 ME/MA/MC/MF	ROE90514	ROE90517
MAN	TG 3 mit/with/avec/con/con MMT3-Ad- vanced-Navi	OP2D0/OP2D1/OP2D2/ OP2D3	ROE90514	ROE90520
Mercedes-Benz	MB ACTROS MP5	J9P	ROE90513	ROE90516
VOLVO	Bupmon, SEM-Einheit	Video-Switch	ROE90513	ROE90518
IVECO	Iveconnect	SW 2910	ROE90513	ROE90519
SCANIA	7" Premium Radio	P/G/R/S-Serie	ROE90514	ROE90520





Aufrüstsatz pneumatische Fernbedienung • Upgrade kit pneumatic remote control • pièce de conversion de la commande pneumatique à distance • Kit complementare azionamento a distanza pneumatico • Teleaccionamiento neumático del juego de reequipamiento

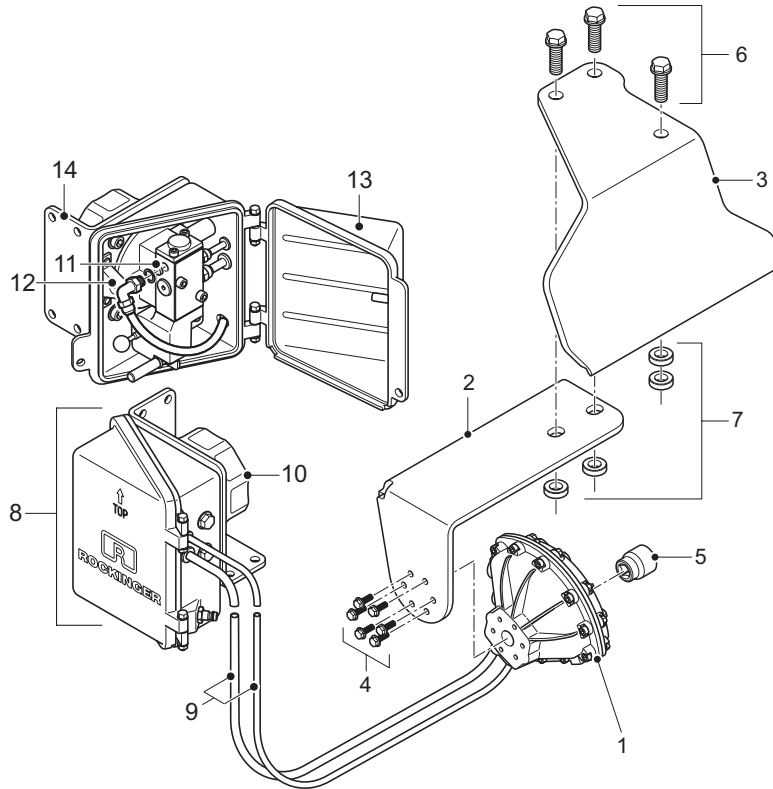

ROE 71461 für / for / pour / per / para RO 400xxx1, RO 430xxx2

ROE 71645 für / for / pour / per / para RO 590xxx1

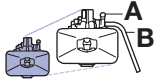
Ersatzteile • Spare parts • Pièces de rechange • Ricambi • Piezas de recambio

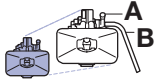

Pos		ROE	
01		ROE 71653	1
02	RO 400/430	ROE 15746	1
02	RO 590	ROE 15750	1
03	RO 400/430 +04	ROE 15727	1
03	RO 590 +04	ROE 15749	1
04		ROE 30479	1
05		ROE 65770	1
06	RO 400/430	ROE 30475	1
06	RO 590	ROE 30476	1
07	RO 400/430	ROE 53672	1

Pos		ROE	
07	RO 590	ROE 53674	1
08		ROE 71420	1
09		ROE 25514	1
10		ROE 90376	1
11		ROE 90379	1
12		ROE 65753	1
13		ROE 76002	1
14		ROE 65752	1



**Aufrüstsatz pneumatische Fernbedienung • Upgrade kit
pneumatic remote control • pièce de conversion de la commande
pneumatique à distance • Kit complementare azionamento
a distanza pneumatico • Teleaccionamiento neumático del
juego de reequipamiento**

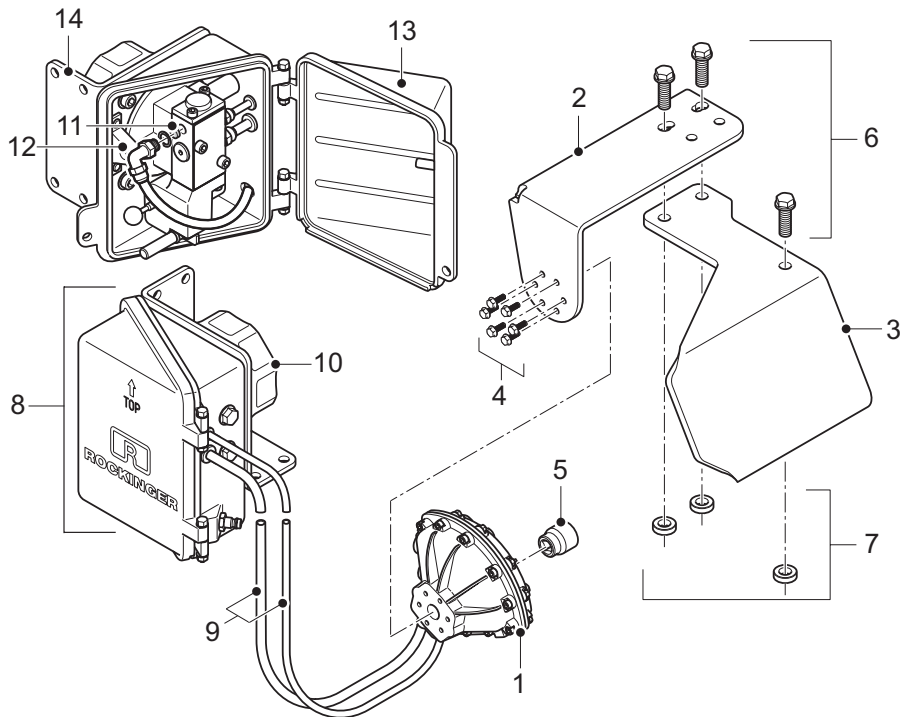

ROE 71459 für / for / pour / per / para RO 410xxx0, RO 413
ab / from / de / da / de T0

ROE 71594 für / for / pour / per / para RO 510x61xxx

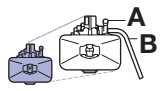
Ersatzteile • Spare parts • Pièces de rechange • Ricambi • Piezas de recambio

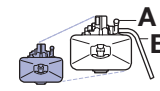

Pos		ROE	
01		ROE 71653	1
02		ROE 15746	1
03	RO 40E/40CH +04	ROE 15745	1
03	RO 50E +04	ROE 15759	1
04		ROE 30479	1
05		ROE 65770	1
06	RO 40E/40CH	ROE 30531	1
06	RO 50E	ROE 30426	1
07	RO 40E/40CH	ROE 53671	1

Pos		ROE	
07	RO 50E	ROE 53674	1
08		ROE 71420	1
09		ROE 25514	1
10		ROE 90376	1
11		ROE 90379	1
12		ROE 65753	1
13		ROE 76002	1
14		ROE 65752	1



Aufrüstsatz pneumatische Fernbedienung • Upgrade kit pneumatic remote control • pièce de conversion de la commande pneumatique à distance • Kit complementare azionamento a distanza pneumatico • Teleaccionamiento neumático del juego de reequipamiento

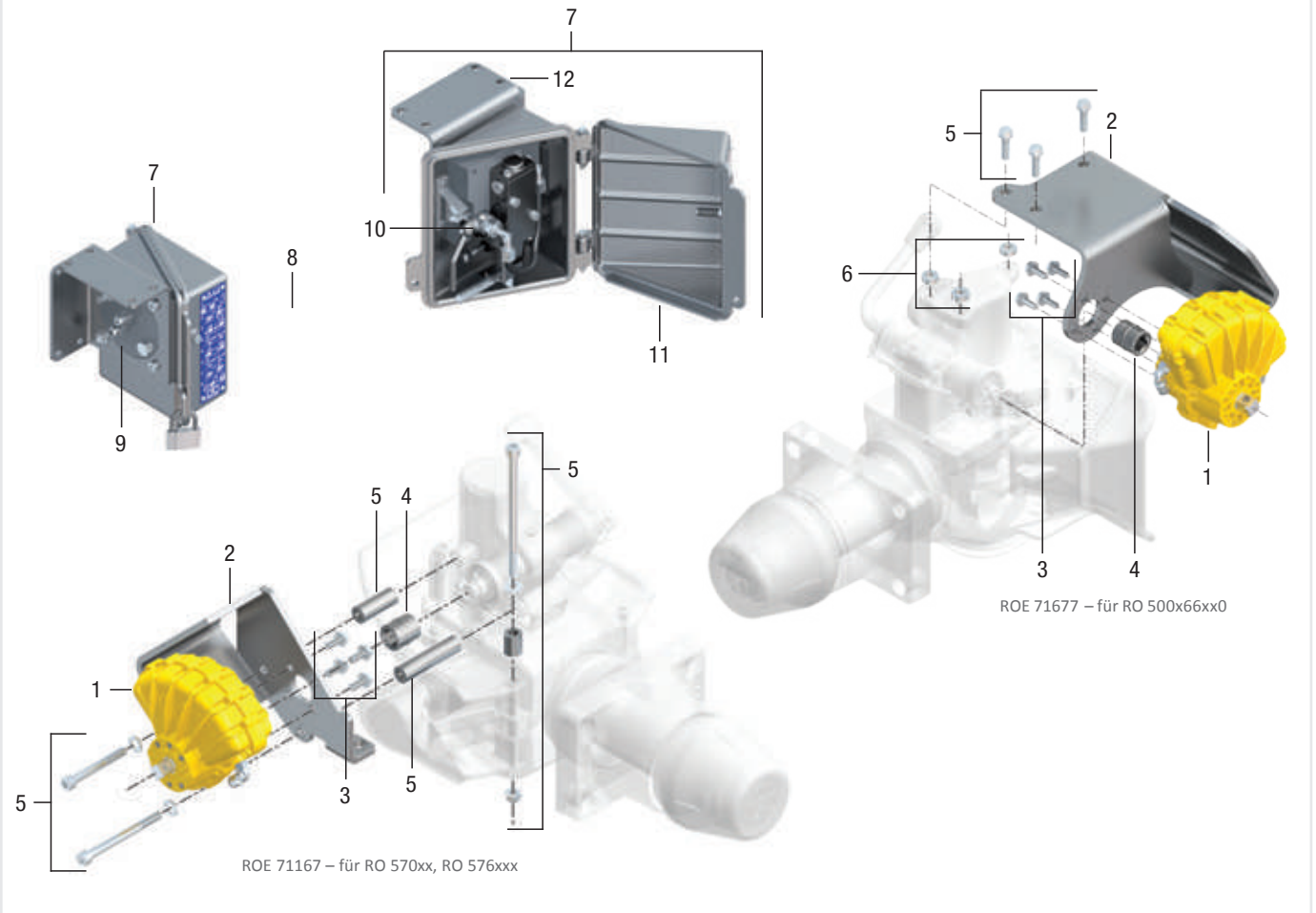

ROE 71677 für / for / pour / per / para RO 500x66xx0

ROE 71167 für / for / pour / per / para RO 570xx, RO 576xxx

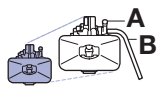
Ersatzteile • Spare parts • Pièces de rechange • Ricambi • Piezas de recambio

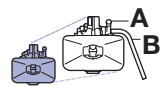

Pos		ROE	
01	+03	ROE 71264	1
02	RO 57/RO 57 flex +05	ROE 71254	1
02	RO 50	ROE 15747	1
03		ROE 30479	1
04		ROE 65726	1
05	RO 50	ROE 30426	1
05	RO 57/RO 57 flex	ROE 71254	1
06	RO 50	ROE 53674	1

Pos		ROE	
07		ROE 71541	1
08		ROE 25514	1
09		ROE 90379	1
10		ROE 65753	1
11		ROE 76002	1
12		ROE 65752	1

Ersatzteile • Spare parts • Pièces de rechange • Ricambi • Piezas de recambio

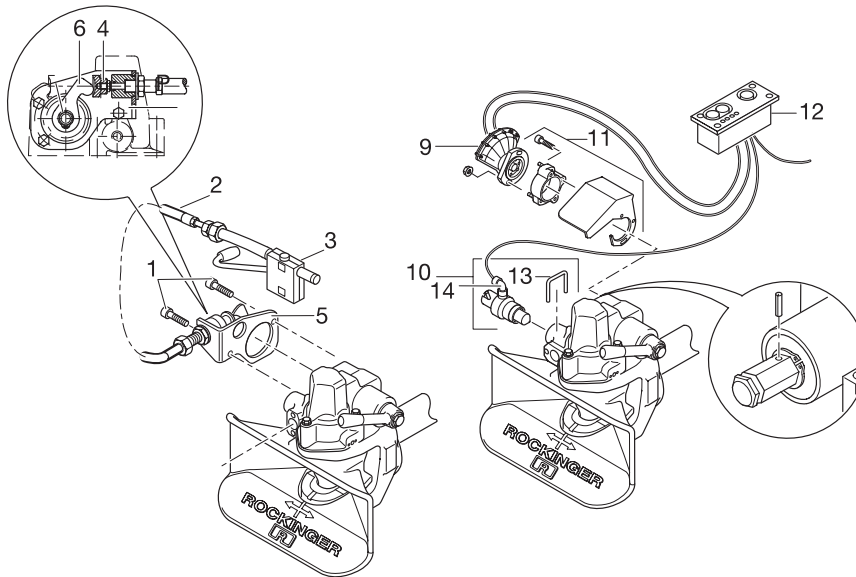

Pos	ROE	
für / for / pour / per / para ROE 70962		
01	ROE 70728	1
02	ROE 57323	1
05	ROE 70984	1
06	ROE 70830	1

Pos	ROE	
für / for / pour / per / para ROE 70844 C		
09	ROE 71076	1
10	ROE 71077	1
11	ROE 71078	1
12	ROE 90299	1
13	ROE 35070	1
14	ROE 90353	1

Pos	ROE	
für / for / pour / per / para ROE 71676		
01	ROE 30426	1
02	ROE 57323	1
05	ROE 65787	1
06	ROE 15768	1



Ersatzteile • Spare parts • Pièces de rechange • Ricambi • Piezas de recambio

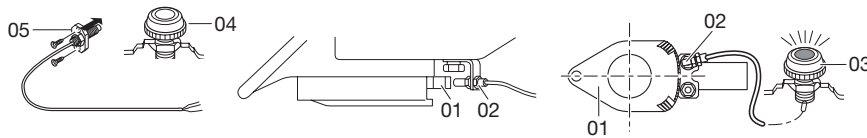

Pos	ROE	
für / for / pour / per / para ROE 70935		
01	ROE 70982	1
02	ROE 70983	1
03	ROE 90293	1

Pos	ROE	
für / for / pour / per / para ROE 70936		
04	ROE 90292	1
05	ROE 70986	1

Elektrische Fernanzeige, Display in der Kabine • In-cab status indicator, display in the cab • Affichage à distance électrique, afficher en cabine • Segnalatore elettronico, schermo nella cabina • Teleindicación eléctrica, monitor en la cabina

ROE 71546 (RI-E)
ROE 71547 (RI-ETW)

Ersatzteile • Spare parts • Pièces de rechange • Ricambi • Piezas de recambio

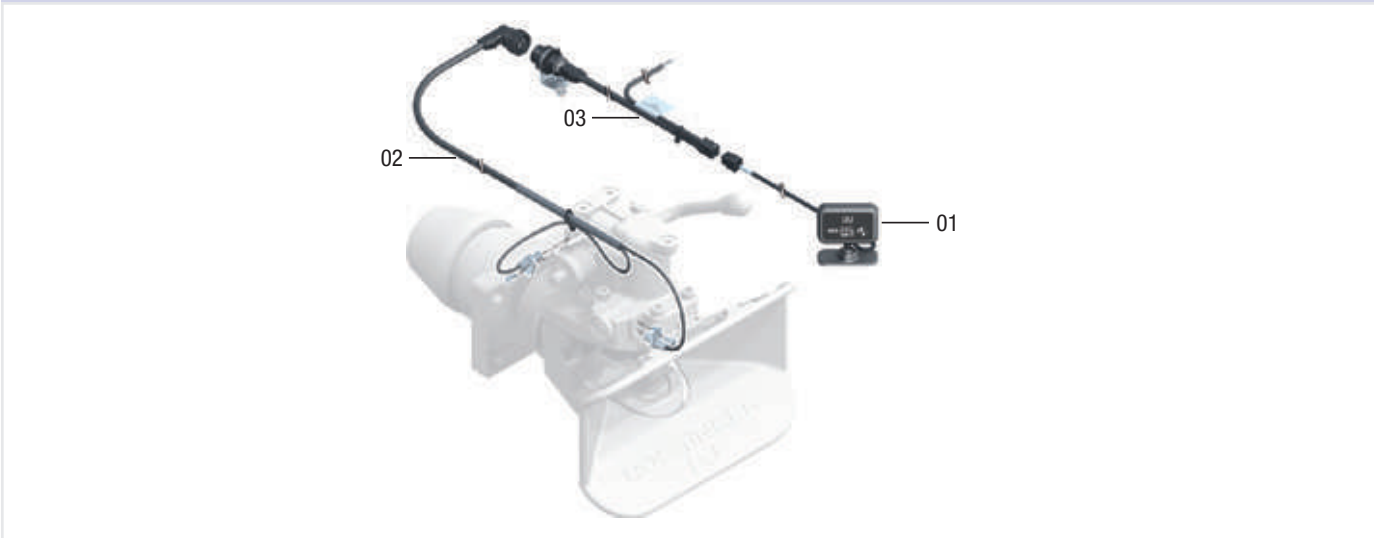

Pos	ROE	
für / for / pour / per / para ROE 71546		
01	ROE 90405	1
02	ROE 71543-2	1

Pos	ROE	
03	ROE 90406	1

Ersatzteile • Spare parts • Pièces de rechange • Ricambi • Piezas de recambio

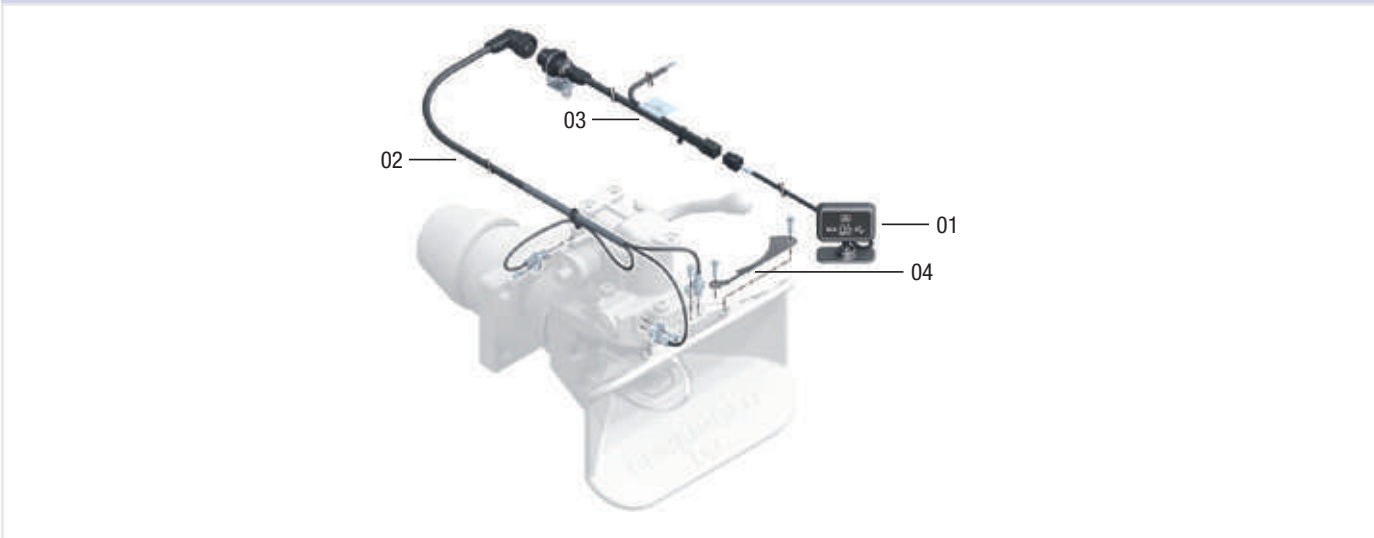



Pos	ROE	
für / for / pour / per / para ROE 71547		
01	ROE 90405	1
02	ROE 71543-3	1

Pos	ROE	
03	ROE 90406	1
04	ROE 65769	1

Elektrische Fernanzeige, Display in der Kabine • In-cab status indicator, display in the cab • Affichage à distance électrique, afficher en cabine • Segnalatore elettronico, schermo nella cabina • Teleindicación eléctrica, monitor en la cabina
 ROE 71654 (RI-BC)

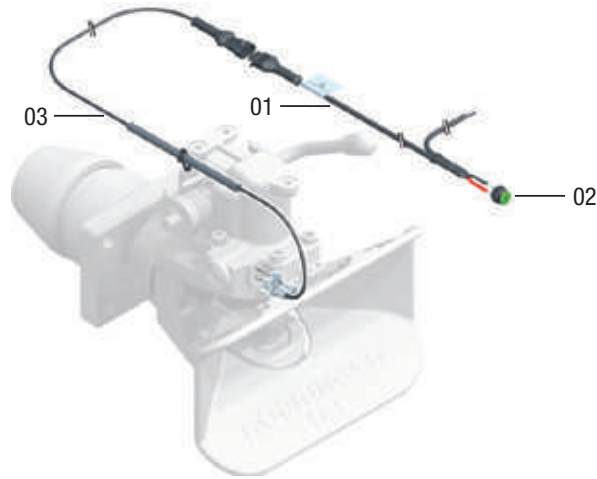
Ersatzteile • Spare parts • Pièces de rechange • Ricambi • Piezas de recambio





Pos	ROE	
01	ROE 90453	1
02	ROE 90451	1

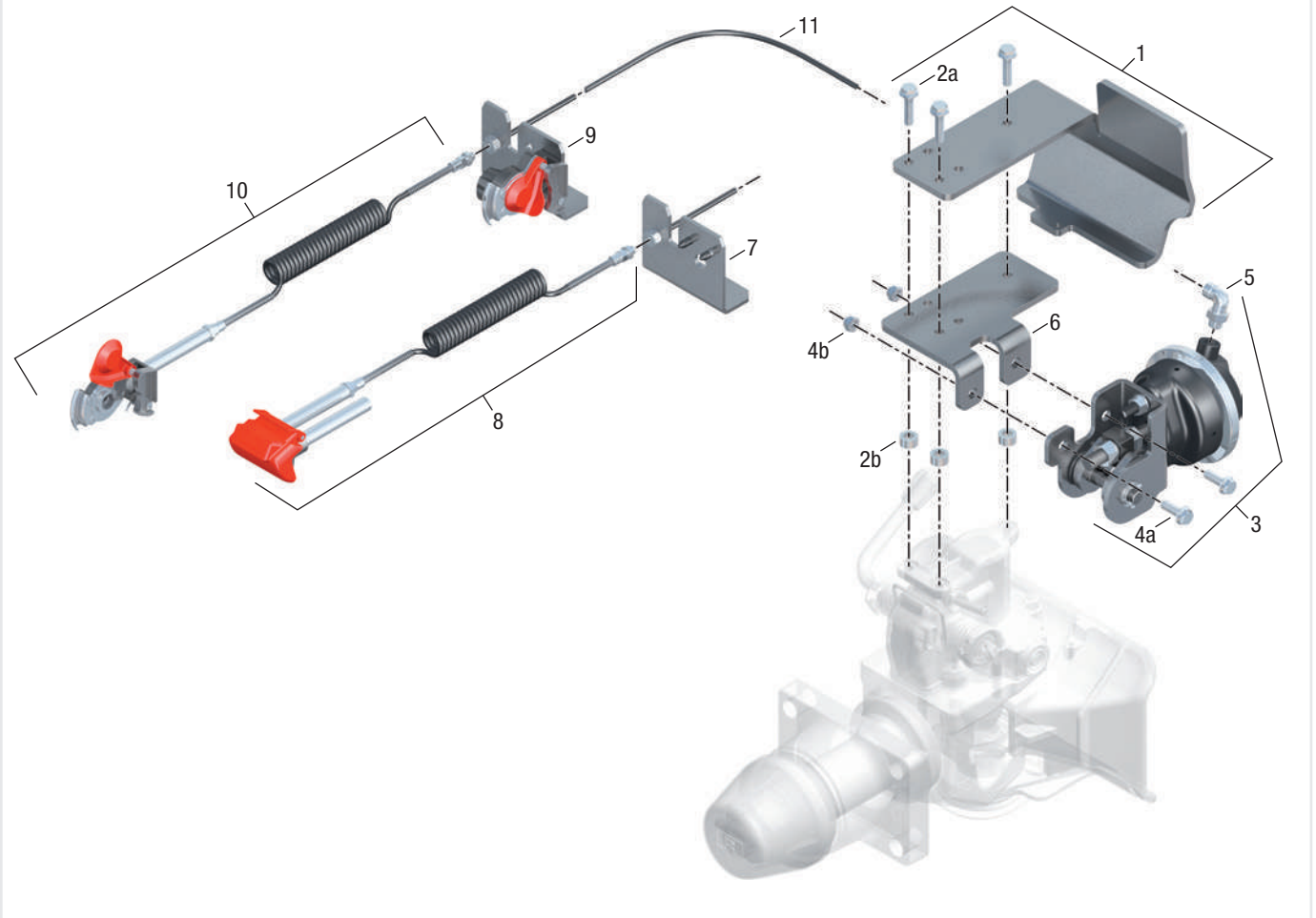

Pos	ROE	
03	ROE 71655	1

**Aufrüstsatz pneumatische Fernbetätigung • Upgrade kit
 pneumatic remote control • pièce de conversion de la commande
 pneumatique à distance • Kit complementare azionamento
 a distanza pneumatico • Teleaccionamiento neumático del
 juego de reequipamiento
 ROE71909-D (RC-PL-2.0)
 ROE71909-P (RC-PL-2.0)**

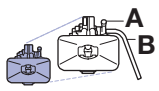
Ersatzteile • Spare parts • Pièces de rechange • Ricambi • Piezas de recambio

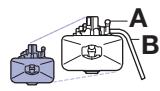

Pos		ROE	
01	+2	ROE 15771	1
02		ROE 71917	1
03	+4, +5	ROE 71910	1
04		ROE 30533	1
05		ROE 90508	1

Pos		ROE	
06		ROE 15772	1
07	für Duomatic	ROE 71912	1
08	für Duomatic	ROE 71914	1
09	für Palm	ROE 71911	1
10	für Palm	ROE 71913	1
11		ROE 25498	1

Schraubensätze • Screw sets • Kits de vis • Kit di viti • Juegos de tornillos







DE Schraubensätze für die Befestigung der Kupplung an der Traverse

EN Screw sets for the fastening of the hitch on the crossbar

FR Kits de vis pour fixation du crochet d'attelage sur la traverse

IT Kit di viti per il fissaggio del gancio sulla traversa

ES Juegos de tornillos para la fijación del enganche al travesaño

			 K (mm)	 K (max. mm)	 (Nm)	ROE
225G110	M 14	8.8	22	22	135	ROE 58094
227G110	M 10	8.8	11-15	11-15	49	ROE 57126
231A0553	M 12	8.8	17	17	85	ROE 70949
231A1153	M 10	8.8	20	20	49	ROE 70923
232A04	M 12	10.9	24	24	125	ROE 70879
232A0453	M 12	8.8	24	24	85	ROE 70873
232A0653	M 12	8.8	18	18	85	ROE 70874
232A11	M 10	10.9	27	27	72	ROE 70878
232A1153	M 10	8.8	27	27	49	ROE 70875
240B04	M 12	10.9	24	24	125	ROE 70879
240B0453	M 12	8.8	24	24	85	ROE 70873
240B06	M 12	10.9	18	18	125	ROE 70880
240B0653	M 12	8.8	18	18	85	ROE 70874
240B11	M 10	10.9	27	27	72	ROE 70878
240B1153	M 10	8.8	27	27	49	ROE 70875
245	M 16	8.8	26	26	210	ROE 58096
253B04	M 12	10.9	24	24	125	ROE 70879
253B0453	M 12	8.8	24	24	85	ROE 70873
253B06	M 12	10.9	18	18	125	ROE 70880
253B0653	M 12	8.8	18	18	85	ROE 70874
253B11	M 10	10.9	27	27	72	ROE 70878
253B1153	M 10	8.8	27	27	49	ROE 70875
256A11/B11	M 10	10.9	20	20	72	ROE 57237
256A35/B35	M 14	10.9	20	20	135	ROE 58094
260G135	M 14	8.8	20	20	135	ROE 58094
260G145	M 16	8.8	28	28	210	ROE 58096
260G150	M 20	8.8	28	28	410	ROE 58097
263G135	M 14	8.8	20	20	135	ROE 58094
263G140	M 16	8.8	28	28	210	ROE 58096
263G150	M 20	8.8	28	28	410	ROE 58097
283A35	M 14	8.8	20	20	135	ROE 58094
283A45	M 16	8.8	28	28	210	ROE 70952
283A50	M 20	8.8	28	28	410	ROE 70509
400G135	M 14	8.8	11-32	32	135	ROE 70970
400G145	M 16	8.8	11-35	35	210	ROE 70952
400G150	M 20	8.8	11-35	35	410	ROE 70971
430G145	M 16	8.8	11-28	28	210	ROE 70251
430G150	M 20	8.8	11-28	28	410	ROE 70252
433G145	M 16	8.8	11-28	28	210	ROE 70251
433G150	M 20	8.8	11-28	28	410	ROE 70252
460U135	M 14	8.8	18	18	135	ROE 70970
460U145	M 16	8.8	33	33	210	ROE 70952
460U150	M 20	8.8	28	28	410	ROE 70971
500G3	M 14	8.8	11-32	32	135	ROE 70970
500G4	M 16	8.8	11-35	35	210	ROE 70952
500G5	M 20	8.8	11-35	35	410	ROE 70509
500G61	M 20	8.8	11-32	32	410	ROE 70509
500G62	M 20	8.8	11-35	35	410	ROE 70509
500G65/570	M 20	10.9	28-35	35	580	ROE 71122
530G6	M 20	8.8	11-28	28	410	ROE 70252
56 E	M 16	10.9	30	30	330	ROE 56116-10
500A66xxx	M 20	10.9	30-35	30-35	580	ROE71760
510A60xxx	M 20	10.9	30-35	30-35	580	ROE71760
590xxxx	M 20	10.9	28-32	28-30	520	ROE71589



EN Calculation

Choice of hitch and towing eye

Hitch and towing eye size

- Hole pattern in the crossbar of the towing vehicle
- Hole pattern in the hitch flange
- Pin size of the hitch

Characteristic values

- Values of the hitch
- Values of towing vehicle and trailer (see vehicle registration certificate)
- Values of the towing eye

Truck and trailer:

D-value

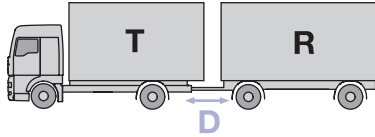

- Theoretical horizontal force between towing vehicle and trailer
- The D-value can only be calculated with the permissible total weight of **both truck and trailer**
- Calculation of the D-value (kN):

$$D \text{ (kN)} = g \cdot \frac{T \cdot R}{T + R}$$

T : total weight of the towing vehicle in t
 R : total weight of the drawbar trailer in t
 g : gravitation acceleration 9,81 m/s²

The calculated D-value can be **equal** to or **lower than** the D-value of the hitch and of the towing eye.
 In case of mounting on a trailer is permitted:

$$D \text{ (kN)} = g \cdot \frac{R_1 \cdot R_2}{R_1 + R_2}$$

R₁ : total weight of trailer where the hitch is mounted
 (max. 24 t) $R_1 \geq R_2$

Towing vehicle and central-axle trailer:

Dc-value

Valid only in connection with the V-value

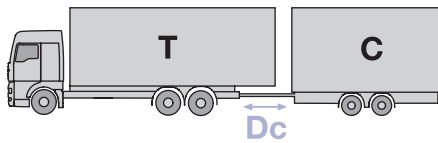

- Theoretical horizontal force between towing vehicle and trailer
- The Dc-value can only be calculated with the permissible total weight of **both truck and trailer**
- Calculation of the Dc-value (kN):

$$Dc \text{ (kN)} = g \cdot \frac{T \cdot C}{T + C}$$

T : total weight of the towing vehicle in t
 C : sum of the axle loads of the central-axle trailer in t
 g : gravitation acceleration 9,81 m/s²

The calculated Dc-value can be **equal** to or **lower than** the Dc-value of the hitch and of the towing eye.

Central-axle trailer: V-value

Valid only in connection with the Dc-value

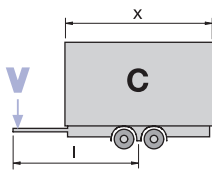

- Vertical force for central-axle trailer
- Dependent on the rear axle suspension of the towing vehicle
- Calculation of the V-value (kN):

$$V \text{ (kN)} = a \cdot \frac{x^2}{l^2} \cdot C$$

a : an equivalent vertical acceleration in the hitch point in m/s²
 a = 1,8 for vehicles with air suspension
 a = 2,4 for vehicles with other suspensions
 l : theoretical drawbar length in meters
 x : length of the loading area in meters
 x^2/l^2 : at least 1,0
 C : sum of the axle loads of the central-axle trailer in t

The calculated V-value can be **equal** to or **lower than** the V-value of the hitch and of the towing eye.

Central-axle trailer:

Static vertical load

Valid only in connection with the V-value

- Vertical load of the central-axle trailer on the hitch point
- The vertical load depends on the size of the hitch and the maximum is 10 % of the gross weight of the trailer or 1.000 kg (whichever is less).

- When using a central-axle trailer the vertical load should amount to at 4 % of the trailer weight in order to prevent increased wear caused by bouncing of the towing eye.

$\frac{T \cdot R}{T + R}$

DE Für alle aufgeführten Produkte sind **technische Änderungen** vorbehalten.

EN We reserve the right to make changes to the **technical specifications** of all the products depicted in this catalogue.

FR Tous les produits sont présentés sous réserve de **modifications techniques**.

IT Per tutti i prodotti illustrati ci riserviamo il diritto di apportare **modifiche tecniche**.

ES Respecto a todos los productos indicados se reservan **modificaciones técnicas**.

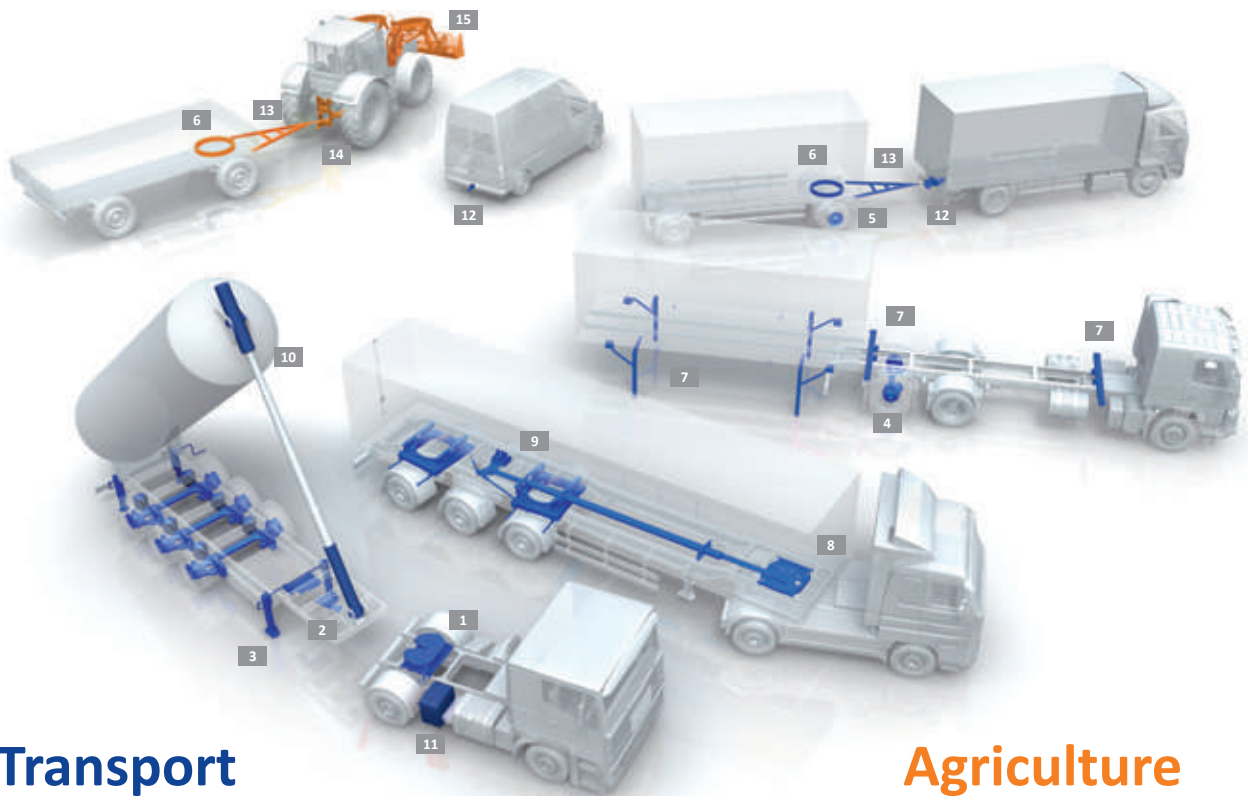

Transport

JOST

- 1-3 Systeme**
Systems
Systèmes
Sistemi
Sistemas
- 1 Sattelkupplungen**
Fifth wheel couplings
Sellettes d'attelage
Ralle a perno
Quintas ruedas
- 2 Königszapfen**
King pins
Pivots d'attelage
Perni ralla
Pivotes de trole
- 3 Stützwinden**
Landing gears
Béquilles
Sollevatori telescopici
Dispositivos de apoyo
- 4 Truck- und Trailerachsen**
Truck and Trailer axles
Essieux de tracteurs et de remorques
Assali per autoarticolati e rimorchi
Ejes para camiones y remolques
- 5 Hubodometer**
Hubodometers
Hubodomètres
Contachilometri
Hubodómetros
- 6 Kugellenkränze**
Ball bearing turntables
Ronds d'avant train à billes
Ralle a sfera
Coronas de dirección de bolas
- 7 Containertechnik**
Container technology
Porte-conteneurs
Tecnica per container
Técnica de contenedores

TRIDEC

- 8 Lenksysteme**
Steering systems
Systèmes de direction
Impianti sterzanti
Sistemas de dirección
- 9 Achsaufhängungen**
Axle suspensions
Suspension d'essieux
Sospensioni assali
Suspensiones de ejes

Edbro

- 10 Hydraulikzylinder**
Hydraulic cylinders
Cylindres hydrauliques
Cilindri idraulici
Cilindros hidráulicos
- 11 Hydraulische Zugmaschinenrüstungen**
Hydraulic component kits
Kits hydrauliques
Kits idraulici
Kits hidráulicos

ROCKINGER

- 12 Anhängerkupplungen**
Towing hitches
Crochets d'attelages
Ganci di Traino
Enganches para remolque
- 13 Zuggabeln und Zugösen**
Drawbars and towing eyes
Flèches et anneaux de remorquages
Timoni e occioni di traino
Barras ahorquilladas de tracción
y puntas de lanza

Agriculture

JOST

- 6 Kugellenkränze**
Ball bearing turntables
Ronds d'avant train à billes
Ralle a sfera
Coronas de dirección de bolas

TRIDEC

- Achsaufhängungen**
Axle suspensions
Suspension d'essieux
Sospensioni assali
Suspensiones de ejes

ROCKINGER

- 14 Anhängesysteme**
Coupling systems
Systèmes d'accouplement
Sistemi di accoppiamento
Sistemas de acoplamiento
- 13 Zuggabeln und Zugösen**
Drawbars and towing eyes
Flèches et anneaux de remorquages
Timoni e occioni di traino
Barras ahorquilladas de tracción
y puntas de lanza

Quicke

- 15 Frontlader und Arbeitsgeräte**
Front loader and implements
Chargeur frontal et outils
Caricatore frontale e attrezzi
Cargador frontal e implementos