

EA

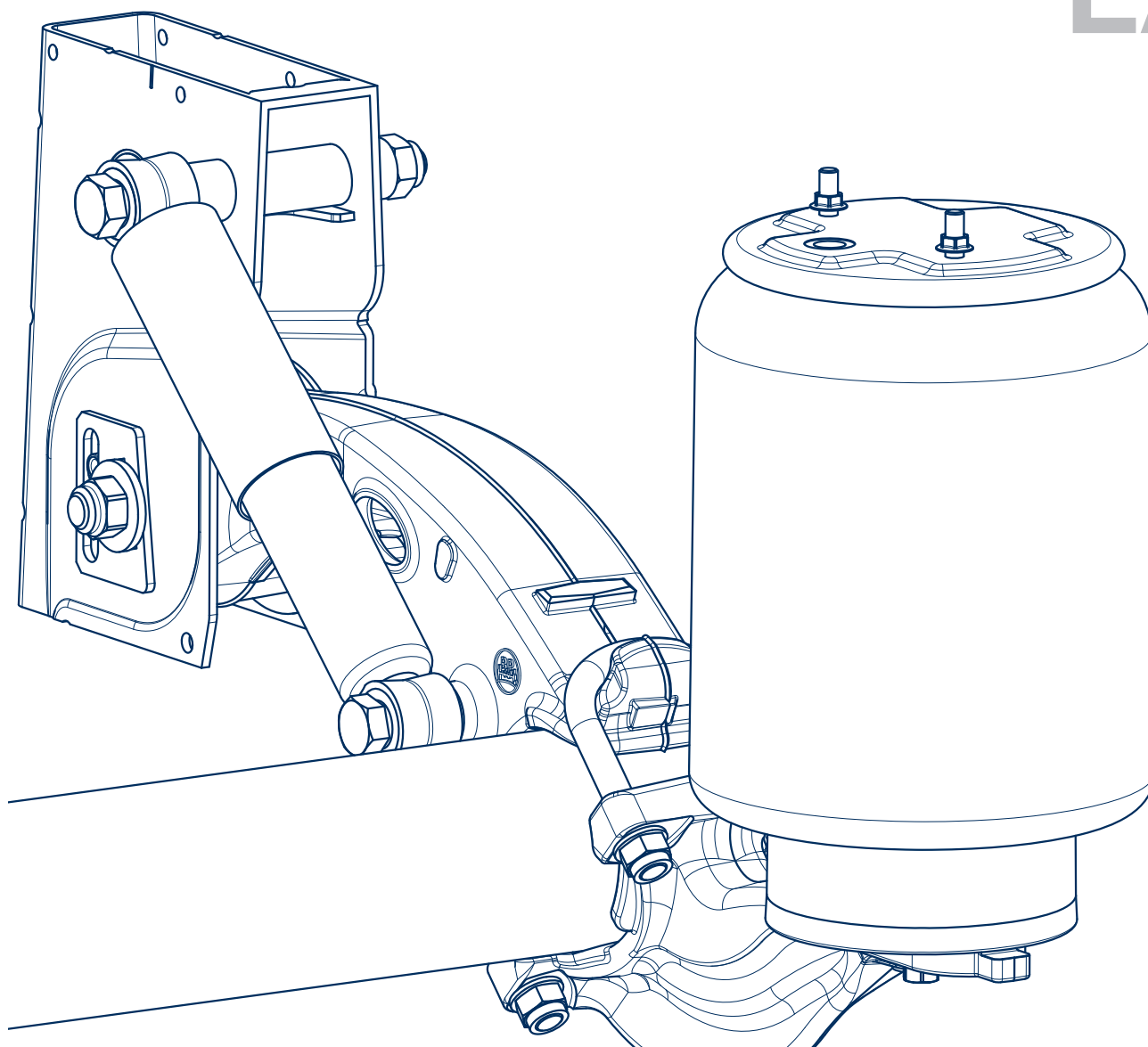

Workshop manual

BPW air suspension kits
for ECO Air running gear systems



Valid: 01/09/2019

Subject to change without notice.

Current versions and additional information can be found online at www.bpw.de.

Contents

◎ 1. Product identification	Page 4
1.1 Explanation of BPW axle type (extract)	Page 4
1.2 Explanation of BPW item numbers (extract)	Page 5
◎ 2. Special tools	Page 6
◎ 3. Exploded view / name	Page 8
◎ 4. Tightening torques	Page 11
◎ 5. Safety regulations, safety information	Page 12
5.1 Safety regulations	Page 12
5.2 Safety information	Page 13
◎ 6. Care and maintenance	Page 14
◎ 7. Replacing air bag beam	Page 20
7.1 Disassembling air bag beam	Page 20
7.2 Installing air bag beam	Page 21
◎ 8. Replacing trailing arm	Page 25
8.1 Disassembling trailing arm	Page 25
8.2 Installing trailing arm	Page 26
◎ 9. Removing and installing axle	Page 29
9.1 Disassembling axle	Page 29
9.2 Installing axle	Page 29
◎ 10. Replacing rubber-steel bush in trailing arm	Page 34
10.1 Disassembling rubber-steel bush	Page 34
10.2 Installing rubber-steel bush	Page 36
◎ 11. Removing and installing air bag	Page 39
11.1 Disassembling air bag	Page 39
11.2 Installing air bag	Page 41
11.3 Dismantling and assembling air bag with central bolt	Page 44
11.4 Dismantling and assembling air bag with universal plate	Page 45
11.5 Dismantling and assembling combi air bag	Page 46
◎ 12. Disassembling and installing shock absorbers	Page 47
12.1 Replacing bushes in shock absorber	Page 48
◎ 13. Disassembling and installing axle lift device	Page 49
13.1 Two-side axle lift	Page 49
13.2 Sidewise mounted axle lift	Page 52
◎ 14. Air suspension valve	Page 55
14.1 General	Page 55
14.2 Replacing	Page 55
14.3 Adjusting	Page 55
◎ 15. Axle alignment check	Page 57
15.1 Conventional axle alignment check	Page 57
15.2 Axle alignment check with laser measuring system	Page 60

- Refer to appropriate workshop manuals for axle repairs

1 Product identification

1.1 Explanation of BPW axle type (extract)

Example

SR	B	F	ACAU	A	9010	VG	30 K	ECO Plus 3	
									Series
									Brake
									Tyre
SR									SR.. <input type="checkbox"/>
SKR									SKR.. <input type="checkbox"/>
R									R <input type="checkbox"/>
	B								For single wheels, wheels with offset
	S								For single wheels, wheels without offset
		F							Wheel studs M 22 x 1.5, without wheel nuts; wheel nuts for bolt or spigot alignment separate
		M							For spigot alignment / Alloy wheel connection
									Air suspension series
									Ride height
			EAAU						EAAU = Cast link type A, air bag beam type U 205 - 350
			EAAM						EAAM = Cast link type A, air bag beam type M 245 - 370
			EAAO						EAAO = Cast link type A, air bag beam type O 335 - 385
			EABU						EABU = Cast link type B, air bag beam type U 260 - 330
			EABM						EABM = Cast link type B, air bag beam type M 300 - 425
			EABO						EABO = Cast link type B, air bag beam type O 330 - 510
				A					With axle lift device
					-				Single axle
					2 /				Tandem axle suspension
					3 /				Tri-axle suspension
						9010			Axle load (kg) + quantity of wheel studs per wheel
							S		Taper mounted hanger brackets (70 mm wide)
							V		Adjustable hanger brackets
							X		With stainless steel hanger brackets
							K		Bolted on hanger brackets
							G		Air bags with split piston
							30		Air bag Ø 300 mm, for stroke 200 mm (standard)
							30-1		Air bag Ø 300 mm, for stroke up to 340 mm
							30 K		Air bag Ø 300 mm, for stroke 150 mm
							36		Air bag Ø 360 mm, for stroke 200 mm (standard)
							36-1		Air bag Ø 360 mm, for stroke up to 340 mm
							36 K		Air bag Ø 360 mm, for stroke 180 mm
								ECO Plus 3	Trailer axle with ECO Plus 3 Unit

1.2 Explanation of BPW item numbers (extract)

Example

73.	68.	01.	0004			
				1st + 2nd position: air suspension module		
71.				Air suspension module, without hanger bracket, without air bag Axle series R / SR		
74.				Air suspension module, without hanger bracket, without air bag Axle series SKR		
72.				Air suspension module, with hanger bracket, without air bag Axle series R / SR		
75.				Air suspension module, with hanger bracket, without air bag Axle series SKR		
73.				Air suspension module, with hanger bracket, with air bag + multi axles Axle series R / SR		
76.				Air suspension module, with hanger bracket, with air bag + multi axles Axle series SKR		
				3rd and 4th position: axle load and bearing system		
				Axle load	Roller bearings	Bearing generation
68.				8000 - 9000 kg	33118 / 33213	ECO Plus 3
				5th + 6th position: Designation for trailing arm and air bag beam		
					Trailing arm	Air bag beam
01.				EAAU	Type A	Type U
02.				EAAM	Type A	Type M
03.				EABM	Type B	Type M
04.				EABO	Type B	Type O
05.				EABU	Type B	Type U
06.				EAAO	Type A	Type O
				7th + 10th position: item number		
				0000 to 9999	Item numbers 0000 - 9999	

2 Special tools

Installation and removal tool for bushes in the trailing arm

Purpose: Pressing rubber-steel bushes

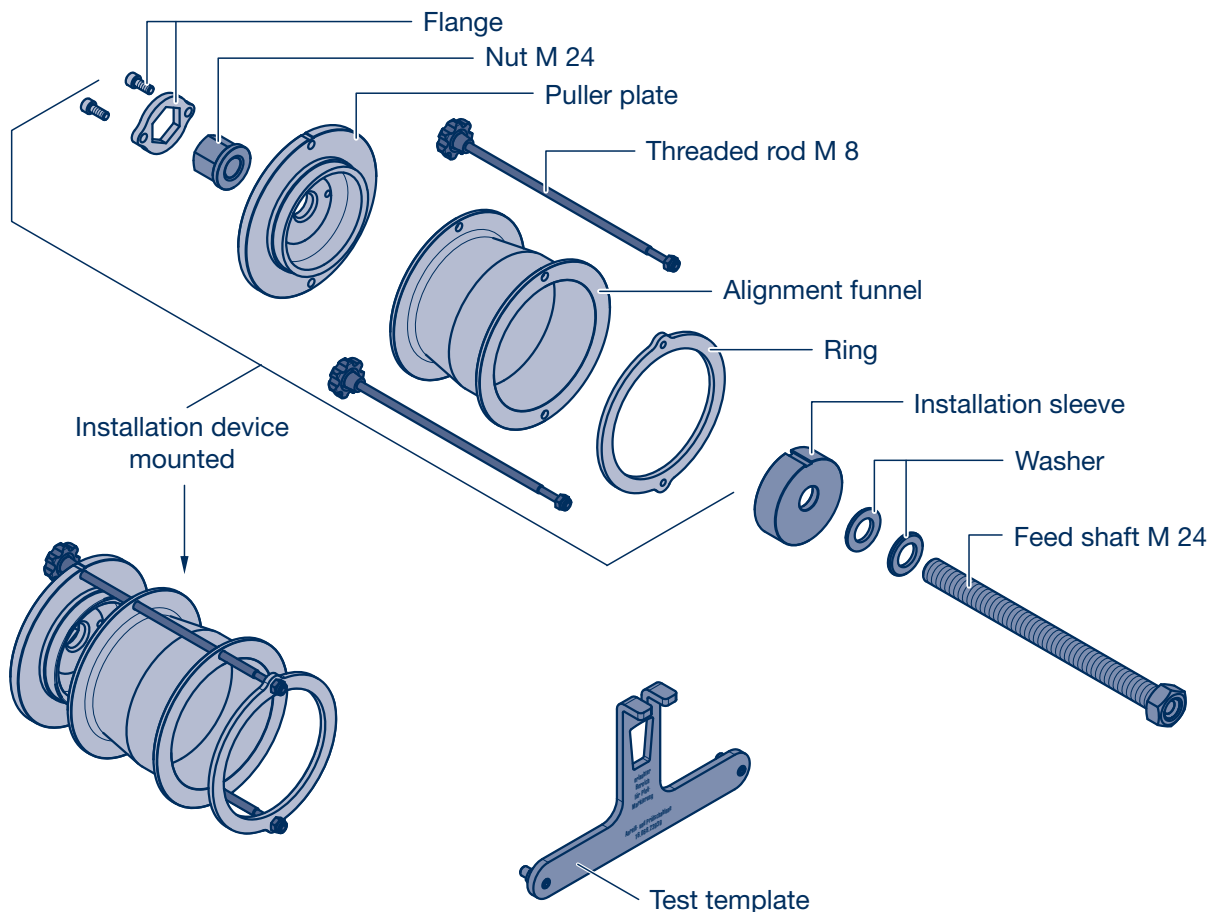

BPW number: 99.00.000.9.69

General notes:



Attention!

Do not use an impact wrench. Use of an impact wrench reduces the life expectancy of the spindle considerably; it is even possible for the threaded parts to fail!

The rubber-steel bush must always be assembled in the direction of travel, as viewed from the right side.

Once nut has become tight, it must be replaced with a new one. Nut and spindle thread must be lubricated with grease (e.g. STABURAGS NBU30 PTM).

The outer surface of the bush, the drilled bushing hole in the trailing arm and the alignment funnel must be sufficiently lubricated with tyre fitting paste as a fitting aid.

When aligning the parts, care must be taken that the notches of all components, the TOP position of the rubber bush and the "Top" marking of the trailing arm are all aligned (>> vehicle top) – see chapter 10.





3 Exploded view

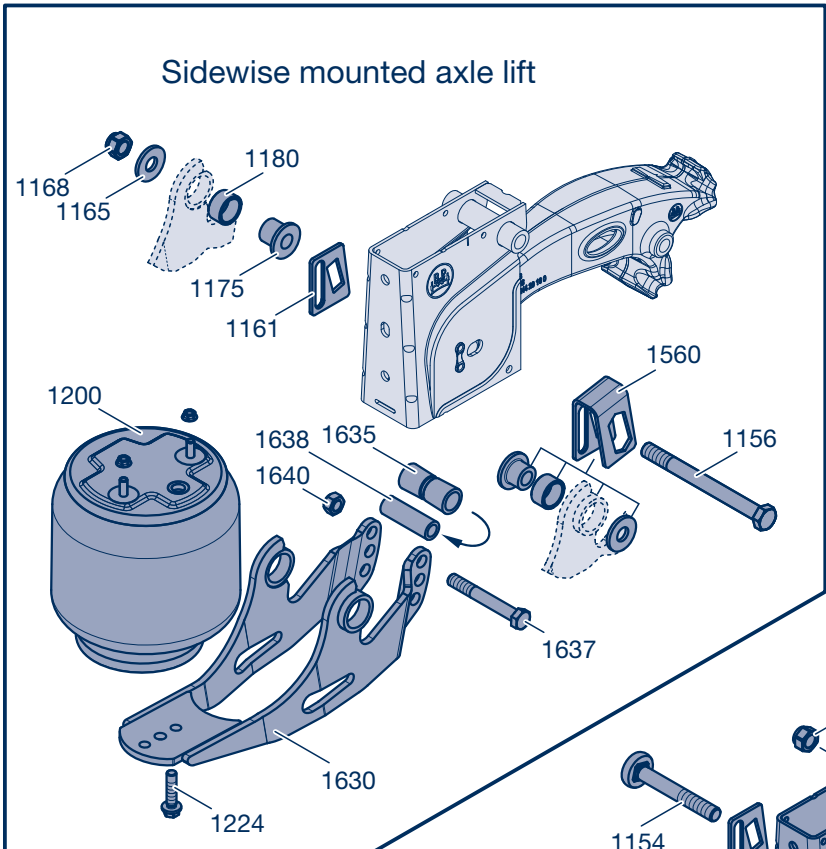

Air bag with central bolt

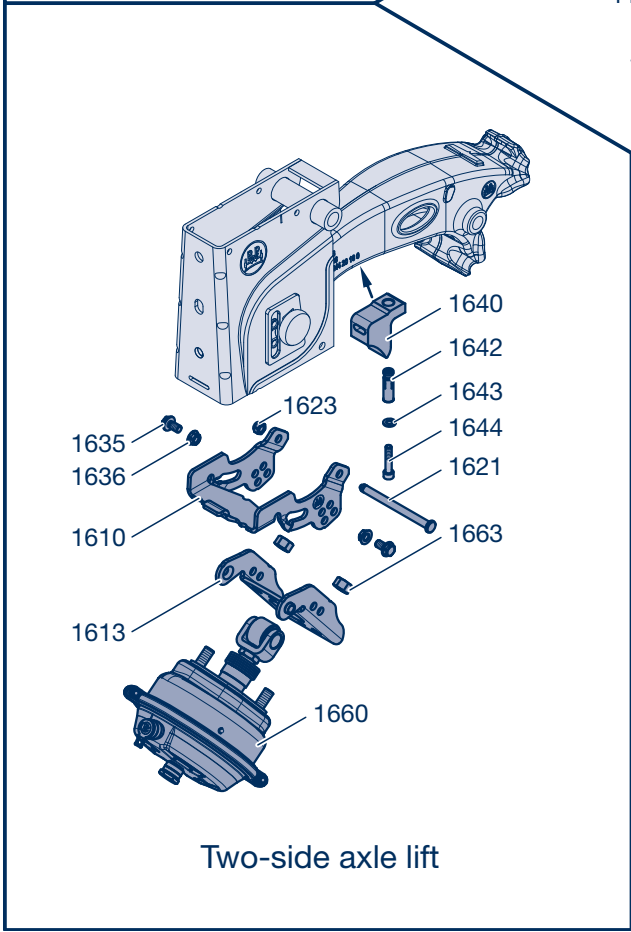
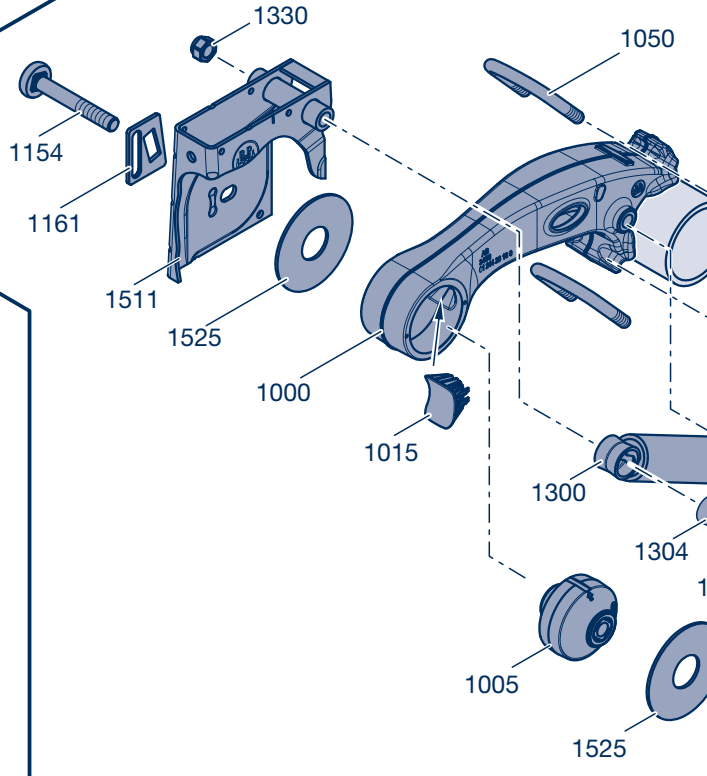

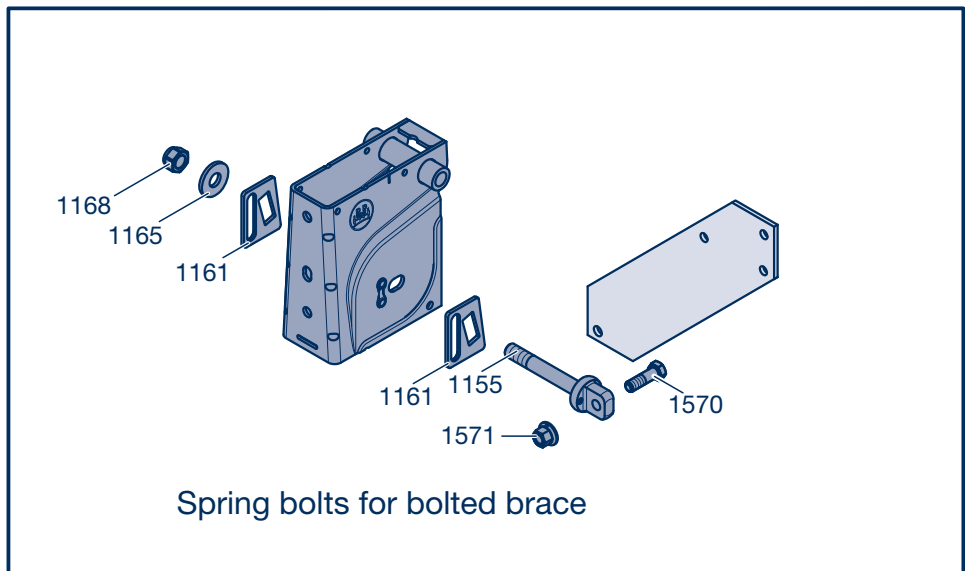
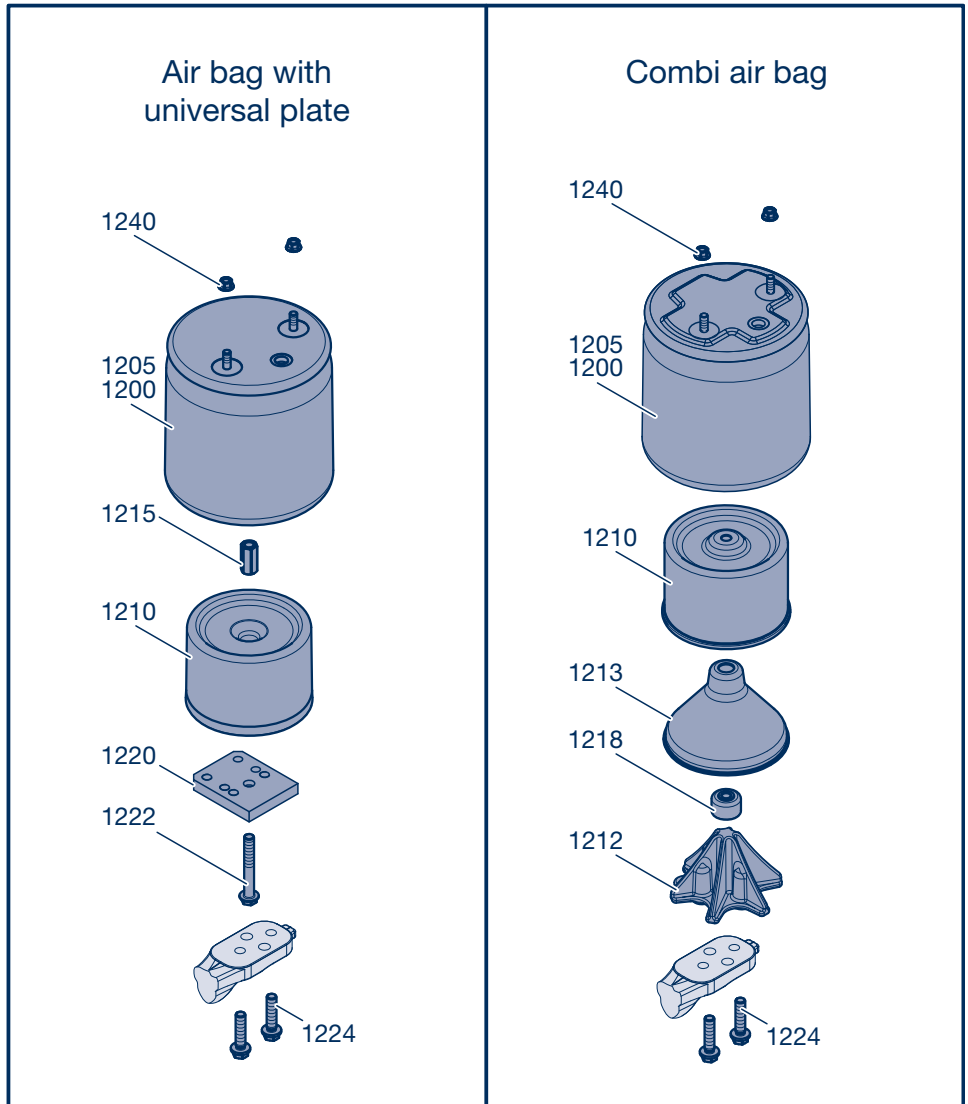
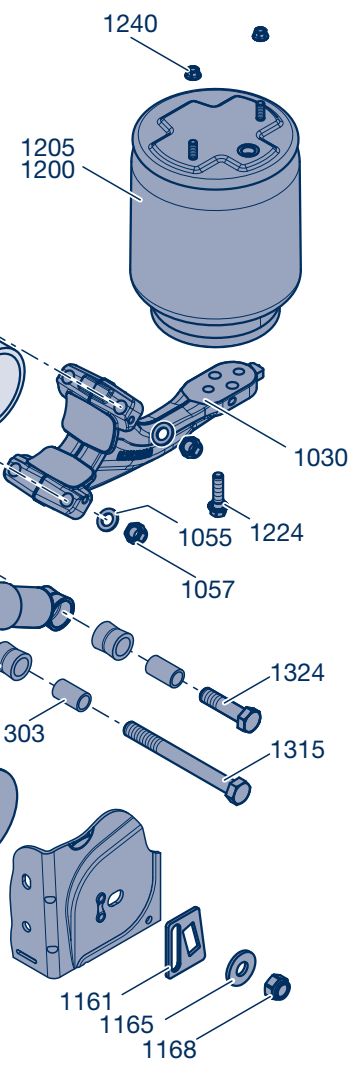

Designation

Item Name

1000	Trailing arm
1005	Bush
1015	Plug
1030	Air bag beam
1050	Spring U-bolt
1055	Washer
1057	Lock nut
1154	Spring bolt
1161	Plate (adjusting plate)
1165	Washer
1168	Lock nut
1200	Air bag assembly
1205	Air bag
1210	Piston
1212	Hanger bracket
1213	Piston
1215	Threaded sleeve
1215	Bolt
1218	Nut
1220	Plate
1222	Locking screw
1224	Locking screw
1240	Lock nut
1300	Shock absorber
1303	Bush
1304	Rubber bump stop
1315	Hexagon screw
1324	Hexagon screw
1330	Lock nut
1511	Hanger bracket, adjustable
1525	Washer

Item Name

Sidewise mounted axle lift

1156	Hexagon screw
1161	Plate (adjusting plate)
1165	Washer
1168	Lock nut
1175	Bush
1180	Bush
1200	Air bag assembly
1224	Locking screw
1560	Adjusting plate with torsion protection
1630	Lifting arm
1635	Bush
1637	Hexagon screw
1638	Tube
1640	Lock nut

Two-side axle lift

1610	Support for two-side axle lift
1613	Shaped plate
1621	Bolt
1623	Lock nut
1635	Locking screw
1636	Lock nut
1640	Shaped part
1642	Dowel
1643	Washer
1644	Cylinder head screw
1660	Diaphragm cylinder for axle lift
1663	Hexagon nut

Spring bolts for bolted brace

1155	Spring bolt
1570	Hexagon screw
1571	Hexagon nut

Tightening torques **4**

Item	Description	Thread / spanner size	Tightening torques
1057	Lock nuts of spring U-bolt	M 20 / SW 30	M = 450 Nm
1168	Lock nut of spring bolt or hexagon screw on axle lift device	M 24 / SW 36	M = 650 Nm (605 - 715 Nm)
1215	Screwed joint, threaded sleeve on air bag	M 16 / SW 24	M = 130 Nm
	Screwed joint, bolt on air bag	M 16	M = 130 Nm
1218	Lower central nut on combi air bag	M 16 / SW 19	M = 130 Nm
1222	Lower central screw on the air bag piston	M 16 / SW 22	M = 230 Nm
1224	Lower fixing screws of air bag	M 16 / SW 22	M = 230 Nm - 300 Nm
	Central screw		M = 300 Nm
1240	Upper lock nuts of air bag	M 12 / SW 17	M = 66 Nm
1324 1330	Lock nut and hexagon screw for shock absorber	M 24 / SW 36	M = 420 Nm (390 - 460 Nm)
1571	Screwed joint, gusset plate on spring bolt	M 18 x 1.5 / SW 27	M = 420 Nm (390 - 460 Nm)
1623	Lock nut of two side axle lift positioning pin	M 10 / SW 16	M = 38 Nm
1636	Screwed joint, shaped plate on two-side axle lift support	M 12 / SW 17	M = 75 Nm
1640	Attachment, roller for sidewise mounted axle lift	M 20 / SW 30	M = 350 Nm (325 - 385 Nm)
1644	Fixing screw, shaped part for two-side axle lift	M 10 / SW 8	M = 50 Nm
1663	Attachment nuts of diaphragm cylinder for axle lift	M 16 x 1.5 / SW 24	M = 190 Nm (180 - 210 Nm)

5 Safety regulations, safety instructions

5.1 Safety regulations

- All work must be performed by trained mechanics at qualified service centres and authorised specialist companies who have access to all relevant tools and have acquired the know-how required for this work. Anyone who performs maintenance and repair work must be trained in automotive mechanics and already have experience in repairing drawbar trailers and semi-trailers. Anyone who performs brake work must be trained in brake systems.
 - Comply with local safety regulations.
 - The relevant operation and service regulations as well as safety regulations of the vehicle manufacturer and of the manufacturers of other vehicle parts must be adhered to.
 - The vehicle must be prevented from moving during repair work. Please observe the relevant safety regulations for repair work on commercial vehicles, in particular the safety regulations for jacking up and securing the vehicle.
 - During all welding work, the trailing arms, air bag beams, spring U-bolts, air bags and plastic lines must be protected against sparks and weld splatter.
 - The earth terminal must under no circumstances be attached to the trailing arms, air bag beams, spring U-bolts or wheel hub.
 - No welding at trailing arms or air bag beams.
 - Heating the air suspension hanger brackets for straightening work is prohibited.
 - During repair work, make sure that the brake is not inadvertently operated. The brake must be released.
 - Do not perform repair work unless wearing protective clothing (gloves, safety boots, safety goggles, etc.) and using the recommended tools.
 - Only use recommended tools.
 - A second mechanic must provide assistance when working with heavy components (trailing arms, air bag beams, brake discs, brake drums or during brake removal/installation).
 - All air lines and components must be depressurised before opening.
 - Following each repair, perform a function check or a test drive in order to make sure that the brakes and suspensions are functioning correctly. New brake linings only have maximum effect after a few braking actions. Avoid hard braking.
 - All exchanged components must be reused or disposed of in accordance with the applicable environmental regulations, laws and directives.
 - The remaining thickness of the brake lining and the condition of the brake disc or brake drum must be visually inspected at regular intervals, depending on the way in which the vehicle is used (see BPW maintenance instructions).
 - Tighten screws and nuts to the prescribed tightening torque.
-

5.2 Safety instructions

This workshop manual contains different types of safety instructions, each of which is marked by an icon and a signal word. The signal word describes the severity of the potential danger.



Warning!

Possible potential danger of serious or fatal injury (severe injury or death).

Caution!

Possible dangerous situation (minor injury or damage to property).



Repair note!

Warning of damage to property or consequential damage if these instructions are not observed.



Note!

Application hints and especially useful information.



Mandatory!

Do not use an impact wrench. Doing so would cause considerable damage!

It is essential that maintenance is carried out in accordance with the prescribed intervals in order to maintain the safe operation and road safety of the vehicle. The relevant operation and service regulations of the vehicle manufacturer and of the manufacturers of other vehicle parts must also be adhered to.

Rectification of any defects discovered or replacement of worn parts should be carried out by a BPW Service Centre or BPW Direct Service Partner, unless the vehicle owner has the required specialist personnel, the required technical facilities and workshop manuals or possesses an official certificate to perform interim inspections or special brake inspections.

When installing spare parts, it is strongly recommended that only original BPW components are used. Parts authorised by BPW for trailer axles and axle units are regularly subjected to special inspections. BPW accepts product responsibility for such parts.

BPW is unable to determine whether all third party products can be used with BPW trailer axles and axle suspensions without any safety risk; this applies even if an authorised testing organisation has accepted the product.

The warranty becomes null and void if spare parts other than original BPW parts are used.

6 Care and Maintenance

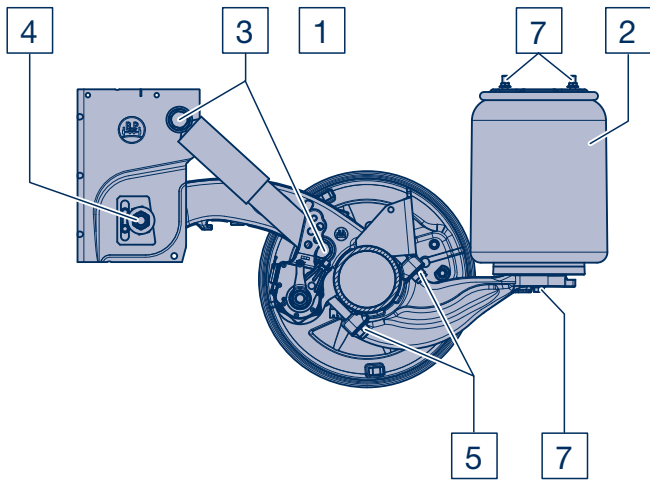

EABO series

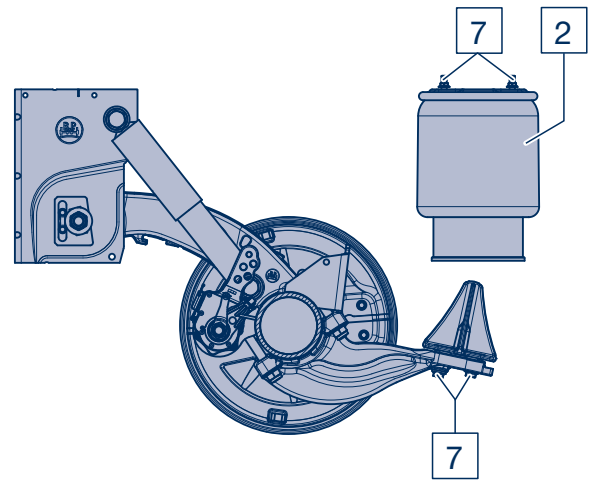

EABO series with Combi Air bag II

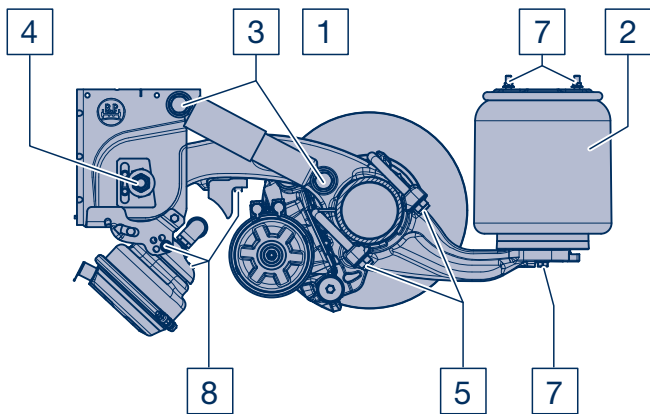

**EAAM / EABM series
with two-sided axle lift**

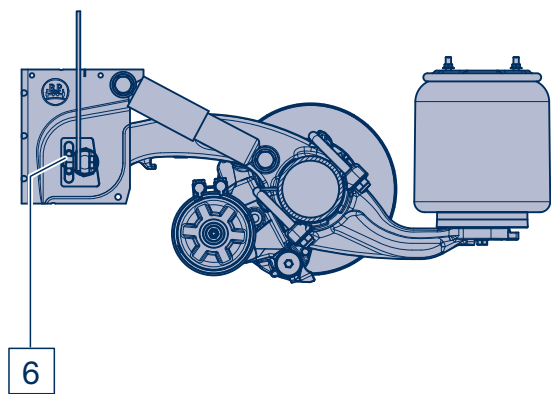

**EABM series
with bolted on gusset plate**

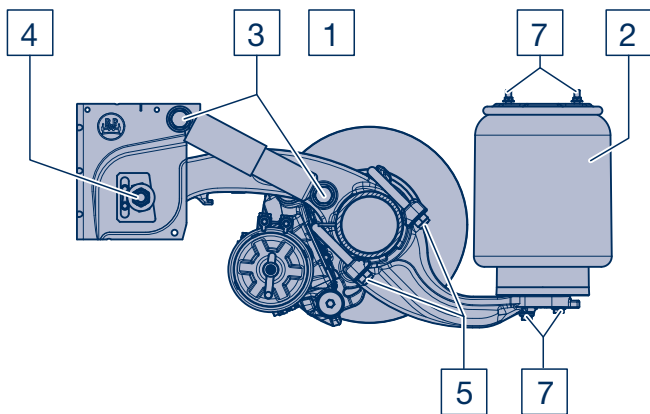

EAAU series

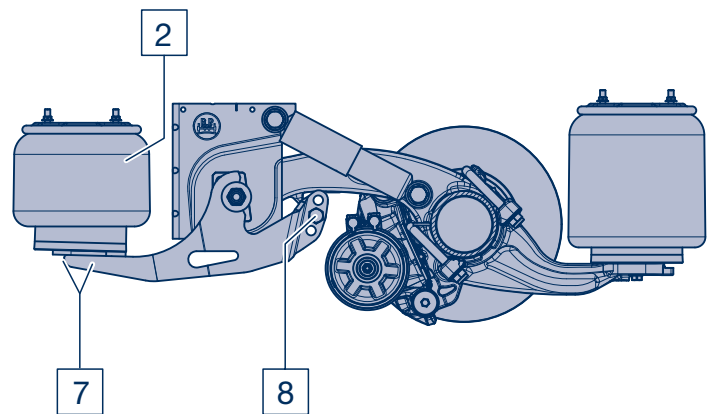

**EAAM series
with sidewise mounted axle lift**

Maintenance and visual inspections

Overview

Visual inspections during the warranty period for running gear fitted with ECO Plus air suspension after 12, 36, 60 and 72 months, thereafter annually

For detailed descriptions, see Pages 16 to 19

1	Air installation kit: Check condition, sealing and tight seat.	1
2	Air bags: Check condition.	2
-	Visual inspection: Check all components and welding seams for damage and wear.	-
3	Check shock absorber attachment for tight seat. Tightening torques with a torque wrench: M 24 (SW 36) M = 420 Nm (390 - 460 Nm)	3
4	Check spring bolts for tight seat. Tightening torques with a torque wrench: M 24 (SW 36) M = 650 Nm (605 - 715 Nm)	4
5	Check spring seat arrangement for tight seat. Tightening torques with a torque wrench: M 20 (SW 30) M = 450 Nm	5
6	Check gusset plate to spring bolt screwed joint for tight seat. Tightening torques with a torque wrench: M 18 x 1.5 (SW 27) M = 420 Nm (390 - 460 Nm)	6
7	Check air bag fastening for tight seat. Tightening torques with a torque wrench: M 12 (SW 17) M = 66 Nm M 16 (SW 22) M = 230 Nm - 300 Nm central screw M 16 (SW 22) M = 300 Nm	7
8	Check axle lift device for tight seat. Tightening torque with torque wrench: Supporting arm M 20 (SW 30) M = 350 Nm (325 - 385 Nm) Diaphragm cylinder M 16 (SW 24) M = 190 Nm (180 - 210 Nm) Hexagon screw M 12 (SW 17) M = 75 Nm Lock nut M 10 (SW 16) M = 38 Nm Cylinder head screw M 10 (SW 8) M = 50 Nm	8



Note!

Components that have damage due to improper attachment may need to be replaced after a review by a BPW Service Centre.

6 Care and Maintenance

1 Air installation kit

– Service intervals as shown on Page 15 –

Check air installation kit valves and line connections for tight seat, damage and sealing. Check valve linkage and attachments (arrows) for damage and tight seat.

The length of the valve lever and permissible angular positions for the valve linkage are shown in the illustration on Page 57.

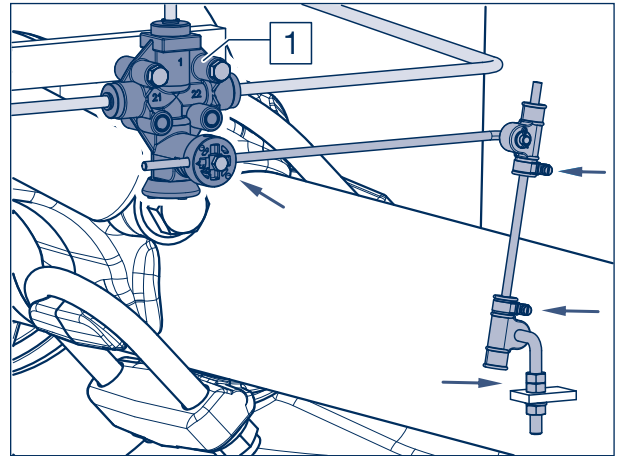

2 Air bags

– Service intervals as shown on Page 15 –

Check air bags for external damage (initiation of cracks, abrasion, crease formation, trapped foreign bodies etc.).

Replace air bags in case of damage.



Warning:

INJURY HAZARD!

No welding should be carried out on steel parts of air bags and pressure vessels!

The air bag should be filled with compressed air only when mounted!

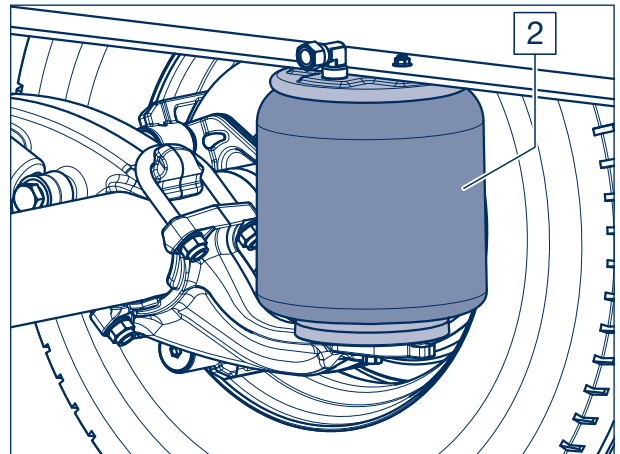

- Visual inspection

– Service intervals as shown on Page 15 –

Check all component parts and welding seams for wear and damage.

3 Shock absorber attachment

– Service intervals as shown on Page 15 –

Check lower and upper shock absorber attachment for tight seat, retighten with a torque wrench if necessary.

Check condition and wear of the rubber bush and replace as necessary.

Check shock absorber for oil leakage. In cases of distinct traces of oil, the shock absorber must be replaced. A light mist of oil is acceptable!

Tightening torques:

M 24 (SW 36) M = **420 Nm** (390 - 460 Nm)

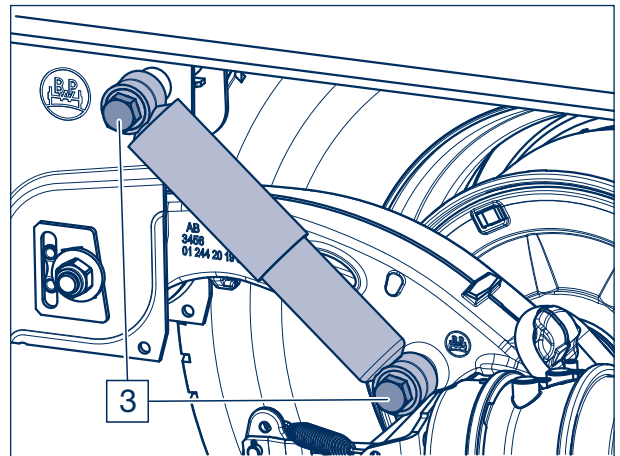

4 Spring bolts

– Service intervals as shown on Page 15 –

Check bushes; move vehicle back and forth slightly with brakes applied or move spring eye with assembly lever with brakes released. No play should be present in the spring eye when doing so (wear limits on Page 34).

If the attachment is loose the spring bolt may be damaged.

- Check the lateral wear washers in the hanger bracket.
- Check the M 24 lock nut on the spring bolt for tight seat.

Tightening torques with a torque wrench:

M 24 (SW 36) M = **650 Nm** (605 - 715 Nm)

The life expectancy of the bearing depends on the tight seat of the spring bolt or the inner bush.

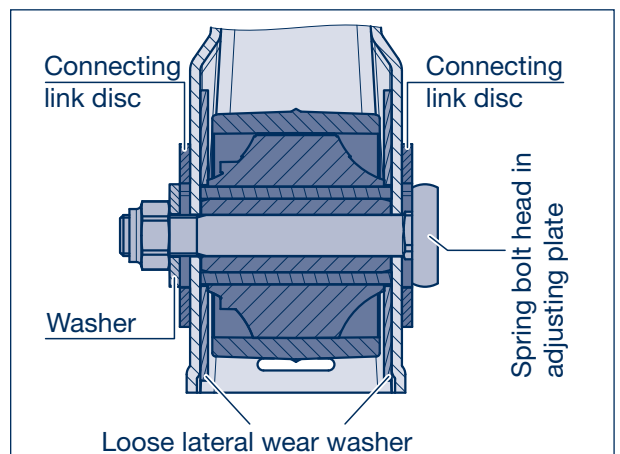
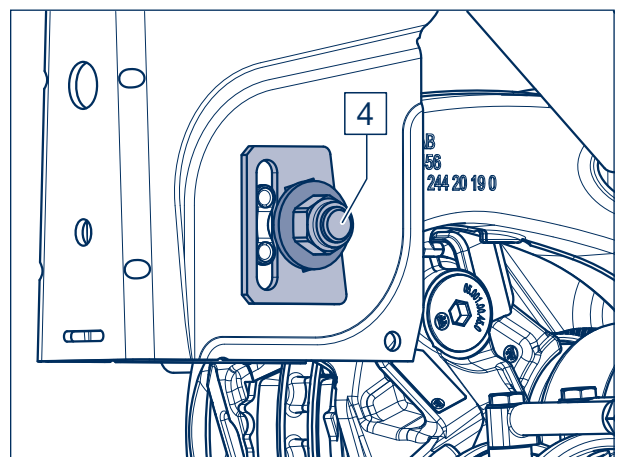

6 Care and Maintenance

5 Spring seat arrangement

– Service intervals as shown on Page 15 –

Check lock nuts of spring U-bolts for tight seat. If the screwed joint has worked loose, tighten nuts diagonally in several steps.

Tightening torque with a torque wrench:
M 20 (SW 30) **M = 450 Nm**

When assembling new spring mounting kit components, tighten the M 20 lock nuts to a tightening torque of $M = 450 \text{ Nm} + 90^\circ$ rotation angle.



Repair note!

No welding should be performed on the trailing arm or air bag beam!

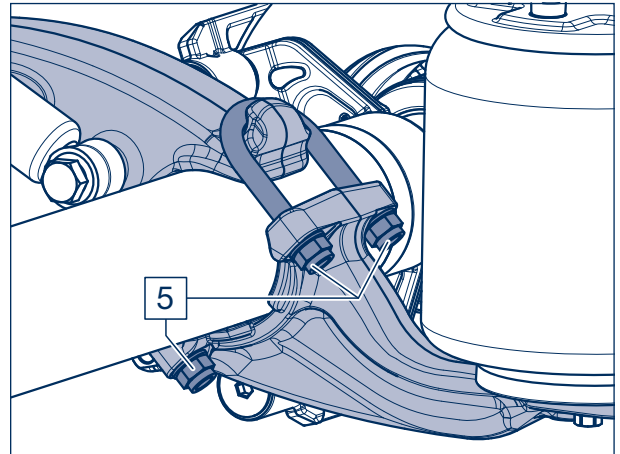

6 Screwed joint, gusset plate spring bolts

– Service intervals as shown on Page 15 –

Check the fixing screws of the gusset plates on the spring bolts for tight seat, retighten with a torque wrench if necessary.

Tightening torque:
M 18 x 1.5 (SW 27) **M = 420 Nm (390 - 460 Nm)**

Assembling or replacing the spring bolt:

1. Unscrew or assemble the spring bolt.
2. Loosely pre-mount the gusset plate with at least three M 16 screws at the top on the cross-member and one M 18 screw at the bottom on the spring bolt and tighten further until contact is made.
3. Set the track.
4. Tighten the spring bolt to the prescribed tightening torque.
5. Tighten the connecting bolt on the gusset plates spring bolt and then tighten the upper connecting bolt to the prescribed tightening torques.

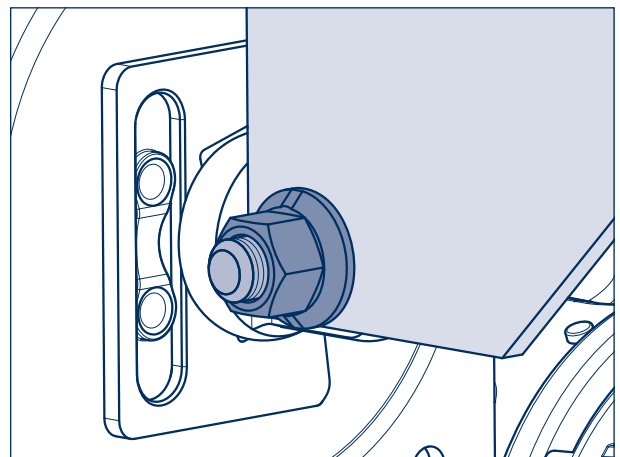
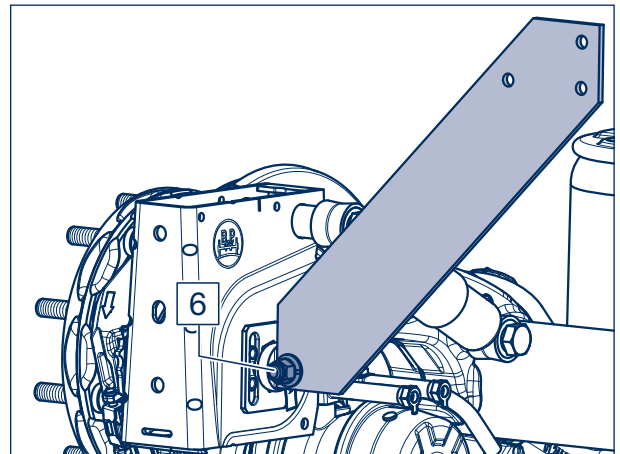

7 Air bag attachments

– Service intervals as shown on page 15 –

Check air bag fixing screws or nuts for tight seat, retighten with a torque wrench if necessary.

Tightening torques:

Upper attachment

M 12 (SW 17) M = 66 Nm

Lower attachment - 2 screws

M 16 (SW 22) M = 230 - 300 Nm

Lower attachment - central screw

M 16 (SW 22) M = 300 Nm

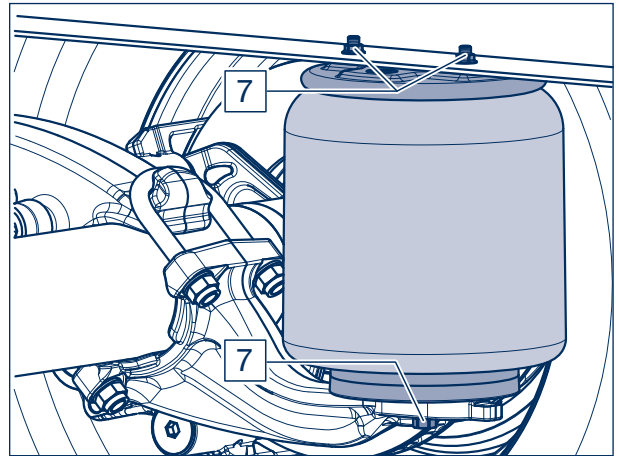

8 Axle lift device

– Service intervals as shown on Page 15 –

Sidewise mounted axle lift:

Check the M 20 lock nut of the roller mounting on the lifting arm for tight seat, retighten with a torque wrench if necessary.

Tightening torque:

M 20 (SW 30) M = **350 Nm** (325 - 385 Nm)

Two-side axle lift:

8a) Check lock nuts of the diaphragm cylinder attachment for tight seat, retighten with a torque wrench if necessary.

Tightening torque:

M 16 (SW 24) M = **190 Nm** (180 - 210 Nm)

8b) Check for tight seat of the bumper fixing screws on the trailing arm.

Tightening torque:

M 10 (SW 8) M = 50 Nm

8c) Check for tight seat of the bracket fixing screws on the shaped plate.

Tightening torque:

M 12 (SW 17) M = 75 Nm

8d) Check the lock nut on the bolt for tight seat.

Tightening torque:

M 10 (SW 16) M = 38 Nm

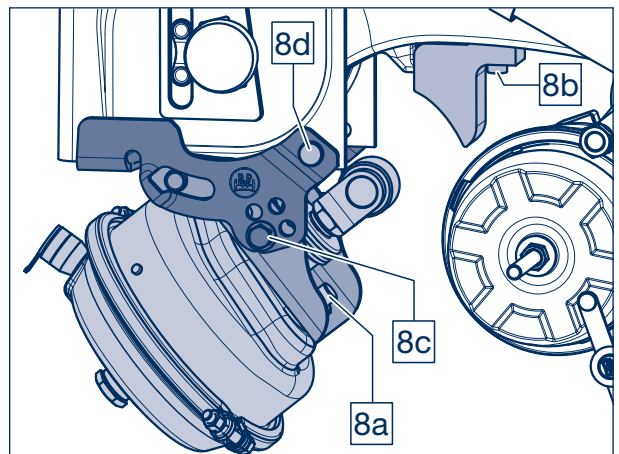
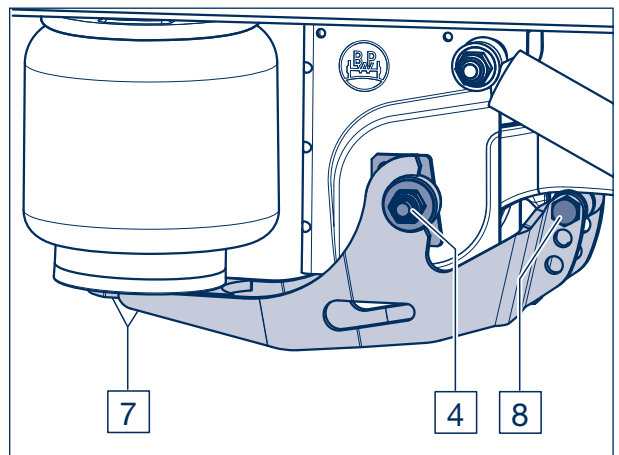

7 Replacing air bag beam

7.1 Removing air bag beam

- [1] Prevent the vehicle from rolling away. Release the service and parking brake.
- [2] Lift vehicle, inflate air bags to maximum height by setting lever for rotary disc valve / change-over valve on air suspension to "Lift" and then to "Stop".

On air suspensions without rotary disc valve / change-over valve, unscrew nut (Figure 2/2) on steering device (Figure 2/1) for air suspension valve on axle and actuate the lever on the air suspension valve until air bags have reached maximum height.



Note!
If air installation kit is defective, use forklift or winches.

- [3] Support frame in this position to prevent accidents.
- [4] Release air from air bags by setting rotary disc valve / change-over valve on air suspension to "Lower".

On air suspension without rotary disc valve / change-over valve, actuate lever on air suspension valve until air has escaped from air bags.

- [5] Lift axle slightly with vehicle jack and remove wheel, if required.



Repair note!
If it is necessary to replace the air bag beam, always replace one complete axle side. This ensures that it is not necessary to align the axle after installation!

- [6] Remove lower locking screw(s) (1224, SW 22), depending on the air bag version (1200).

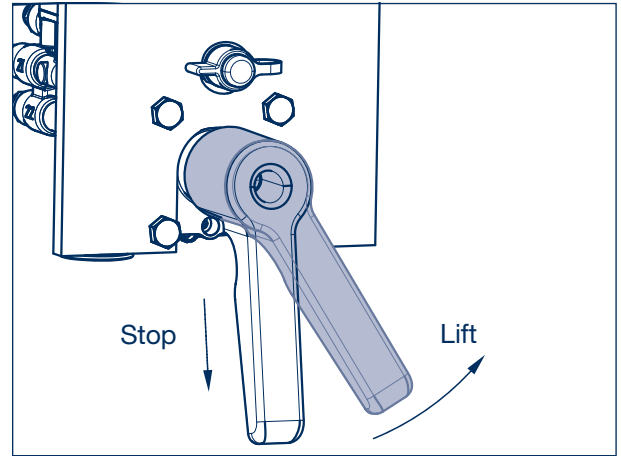

Figure 1

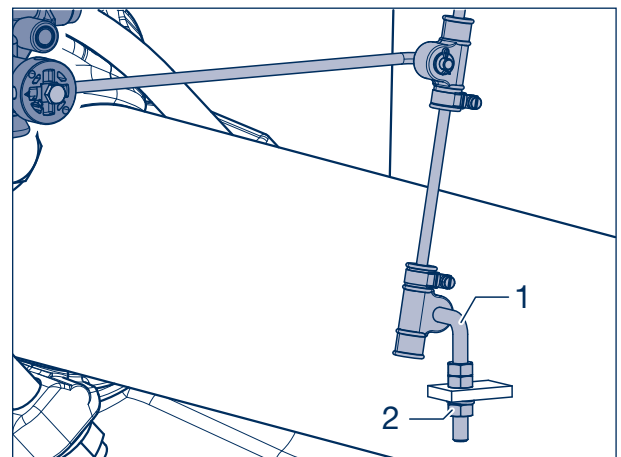

Figure 2

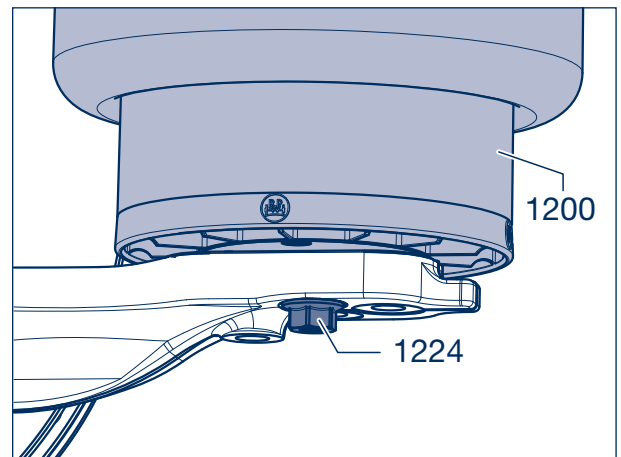

Figure 3

- [7] Measure and note distance from top of air bag beam to bottom of frame.

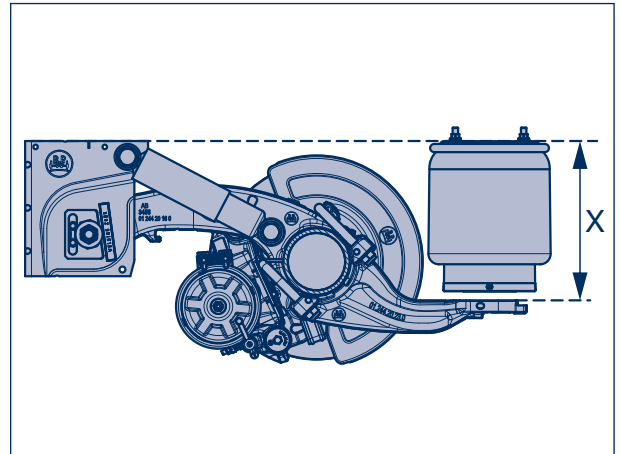

Figure 4

- [8] Mark spring centre position of trailing arm (1000) and air bag beam (1030) onto the axle beam using a coloured marker (mould parting line, arrows).
- [9] Secure air bag beam to prevent falling down.
- [10] Remove lock nuts (1057, SW 30) from spring U-bolts (1050) and remove washers (1055).
- [11] Remove upper and lower spring U-bolt (1050).
- [12] Remove air bag beam.

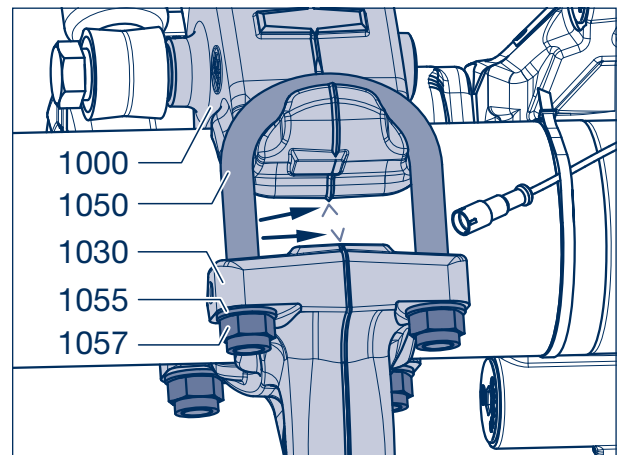

Figure 5

7.2 Installing air bag beam

- [13] Pre-mount new upper spring U-bolt (1050) on air bag beam (1030).
- [14] Position new washers (1055) and screw on new lock nuts (1057) by hand.
- [15] Hook air bag beam with spring U-bolt mounted into bracket on trailing arm (1000).

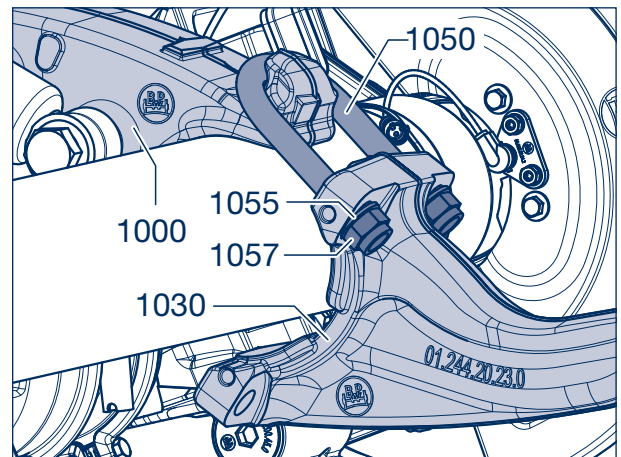

Figure 6

7 Replacing air bag beam

- [16] Install new lower spring U-bolt (1050), position new washers (1055) and screw on new lock nuts (1057).



Repair note!
The thread of the spring U-bolts must not be greased.

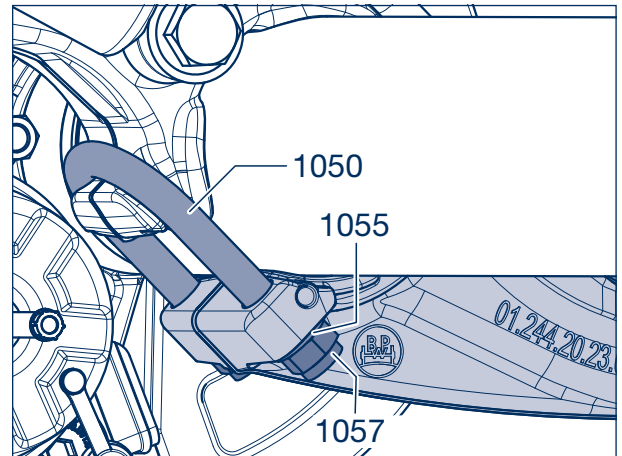

Figure 7

- [17] Align trailing arms (1000) and air bag beam (1030) with spring centre markings (arrows).
- [18] Gently tighten lock nuts (1057, SW 30) - on each spring U-bolt - until all components make uniform contact.



Repair note!
Never tighten lock nuts just on one side, this will prevent unequal tension.

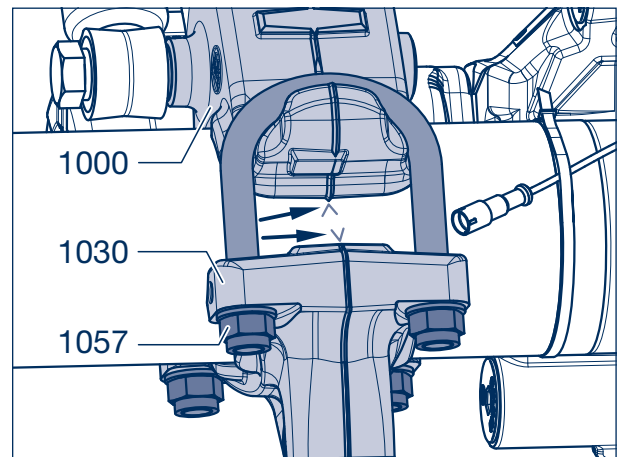

Figure 8



Repair note!
During assembly, make sure the spring U-bolts (1050) and cast components (1000, 1030) move freely towards the axle beam, centre if necessary.

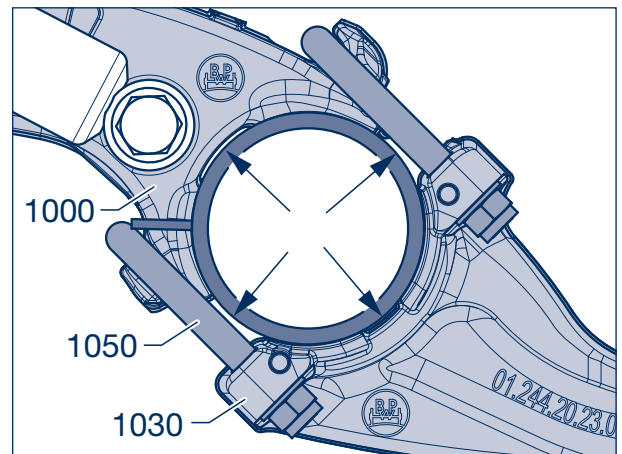

Figure 9

- [19] Tighten lock nuts (1057, SW 30) to tightening torque of 200 Nm diagonally in sequence 1, 2, 3, 4 using torque wrench.

While tightening always ensure that the clearance between the spring U-bolts and axle beam radii, as well as the position of the cast parts (trailing arms and air bag beam) is maintained on the axle beam (coloured marking spring centre, Figure 8).

- [20] Measure distance X (Figure 11). This must coincide with the value noted in work step [7]. Tolerance +/- 1 mm.

If necessary loosen spring U-bolt slightly, correct position and retighten.

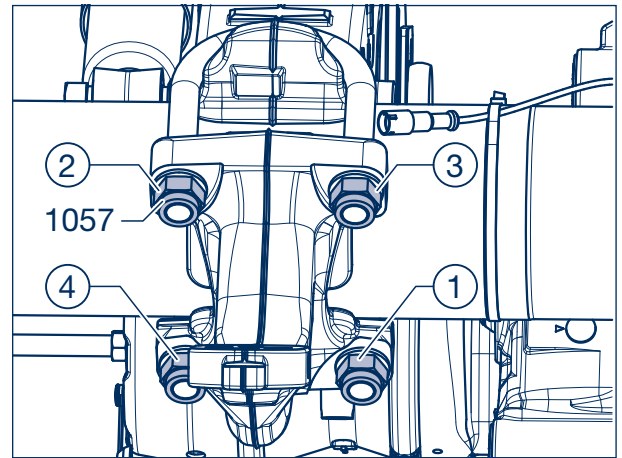

Figure 10

- [21] Tighten all lock nuts to a tightening torque of 350 Nm and then to 450 Nm.
- [22] Finally tighten all lock nuts by turning an additional 90°.



Repair note!
After tightening, an exposed thread must be visible at every spring U-bolt.

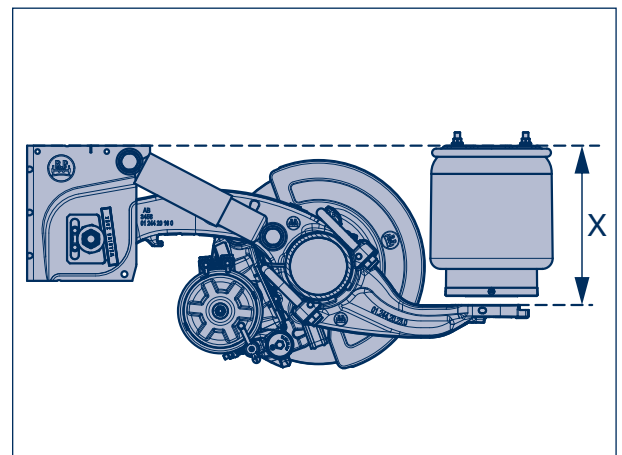



Figure 11

- [23] Clean contact surfaces on air bag and air bag beam (1030).
- [24] Install lower air bag beam attachment. Install locking screw(s) (1224, SW 22) (depending on version of air bags) and tighten to the specified tightening torque.

M 16 (SW 22) M = 230 - 300 Nm

Lower attachment with central screw:
M 16 (SW 22) M = 300 Nm

-  If the air bag has been removed completely, see Installing air bags, Chapter 11.2.

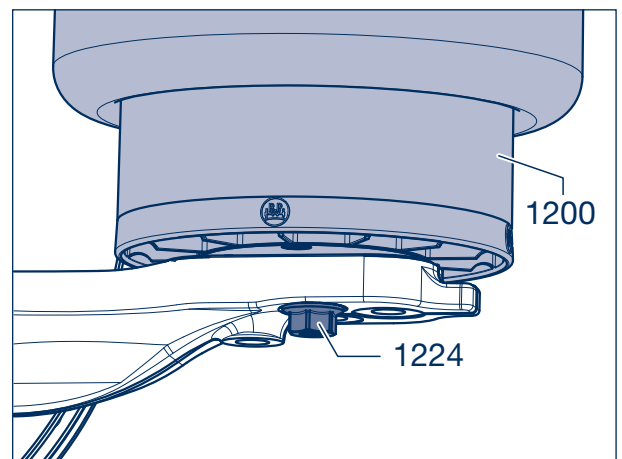

Figure 12

7 Replacing air bag beam

[25] Lower axle and remove vehicle jack.

[26] Inflate air bags by setting rotary disc valve / change-over valve lever for air suspension to "Lift".

On air suspensions without rotary disc valve / change-over valve, actuate the lever on the air suspension valve until air bags are filled with air.

[27] Remove vehicle supports.

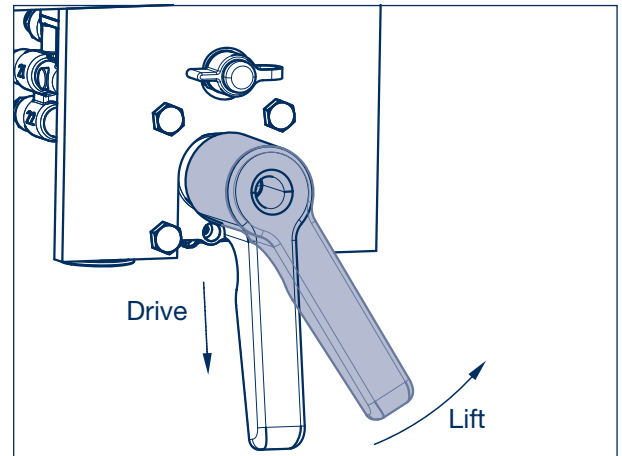

Figure 13

[28] Lower vehicle, deflate air bags to driving position by setting rotary disc valve change-over valve lever on air suspension to "Drive".

[29] On air suspensions without rotary disc valve / change-over valve, screw nut (2) for air suspension valve steering device (1) onto axle. The vehicle is automatically reset to the ride height.

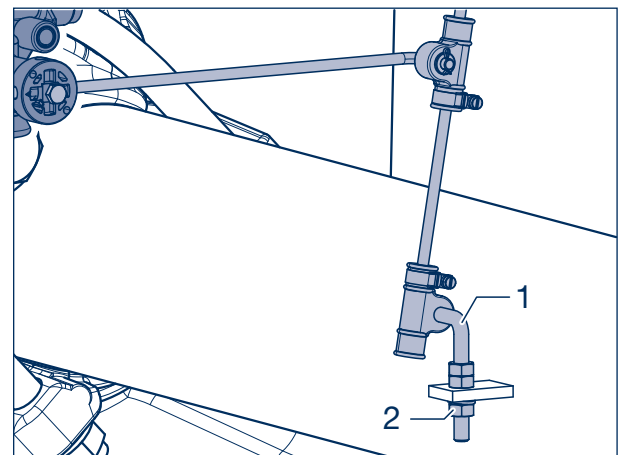

Figure 14

Replacing trailing arm 8

8.1 Disassembling trailing arm



Repair note!

If it is necessary to replace the trailing arm, one axle side must always remain completely mounted.

- [1] Remove air bag beam, see Chapter 7.1.
- [2] Remove bolt (1324, SW 36) for lower shock absorber attachment on trailing arm (1000).

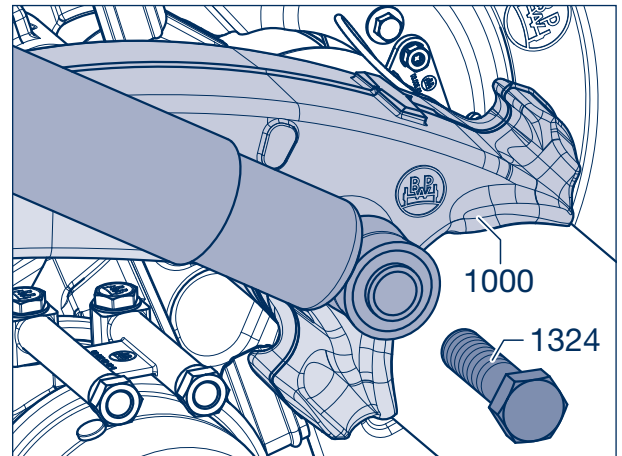

Figure 1

- [3] Screw lock nut (1168, SW 36) off the spring bolt (1154).
- [4] Remove washer (1165) and adjusting plate (1161).



Note!

When brace is bolted on, it is necessary to remove the gusset plates.



Danger! INJURY HAZARD!

When disassembling, ensure that the trailing arm (1000) is secured against falling down. Use a hoist or second person for assistance.

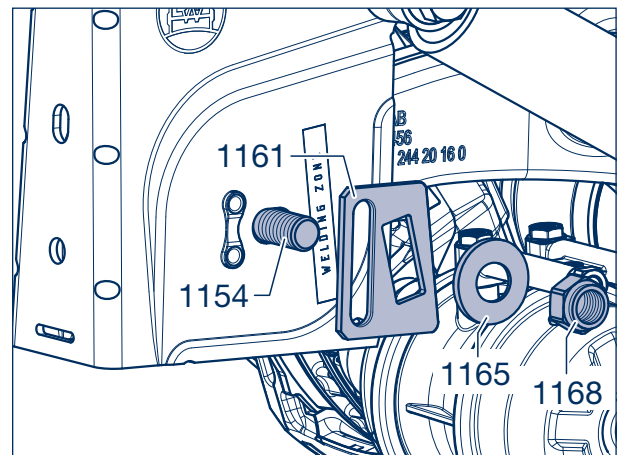



Figure 2

- [5] Drive spring bolts (1154) out of hanger bracket (1511) and trailing arm bush (1005).
-  See Chapter 13 for side-mounted axle lift or two-side axle lift.
- [6] The trailing arm (1000) can then be removed from the hanger bracket and the axle beam; lower axle slightly, if necessary.

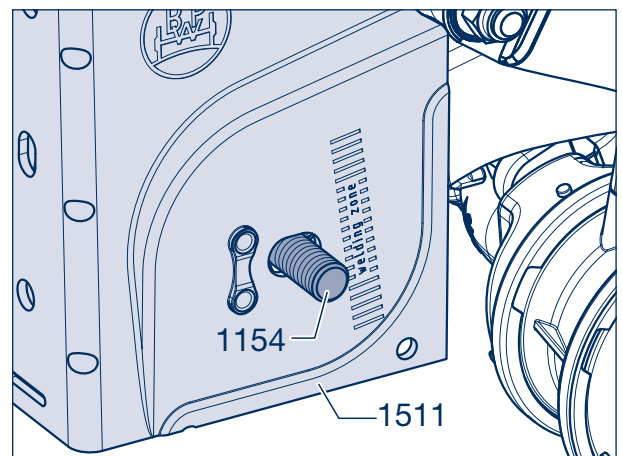

Figure 3

8 Replacing trailing arm

8.2 Installing trailing arm

- [7] Remove dirt from contact surfaces on axle beam, trailing arm and air bag beam.
- [8] Position trailing arm (1000) on axle beam.

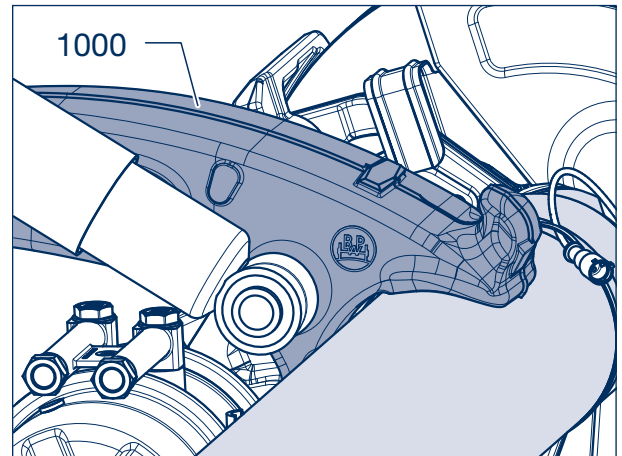

Figure 4

- [9] Install wear washers (1525) on both sides on bush (1005) in trailing arm (1000).

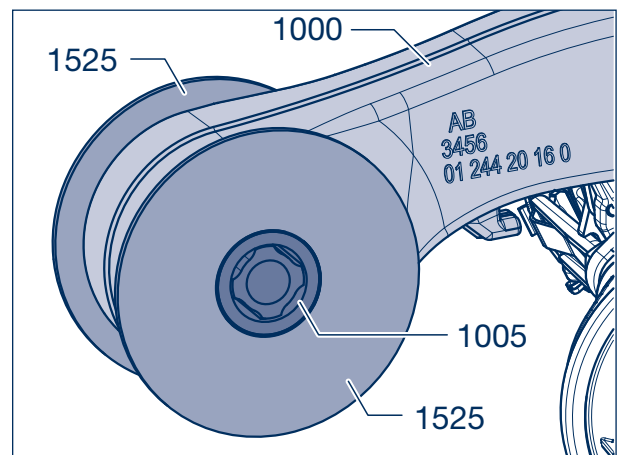

Figure 5

- [10] Push adjusting plate (1161) into the correct position on spring bolt (1154).
- [11] Insert trailing arm (1000) with wear washers (1525) into hanger bracket. Lightly grease new spring bolts (1154) and install from outside to inside.



Note!

On version with bolted brace, install spring bolts (1155) from inside to outside.

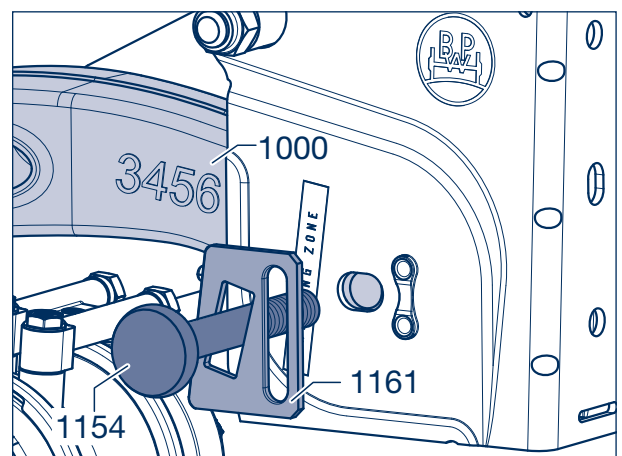

Figure 6

- [12] Place inner adjusting plates (1161) in correct position, install washer (1165) and assemble a new lock nut (1168, SW 36) loosely.

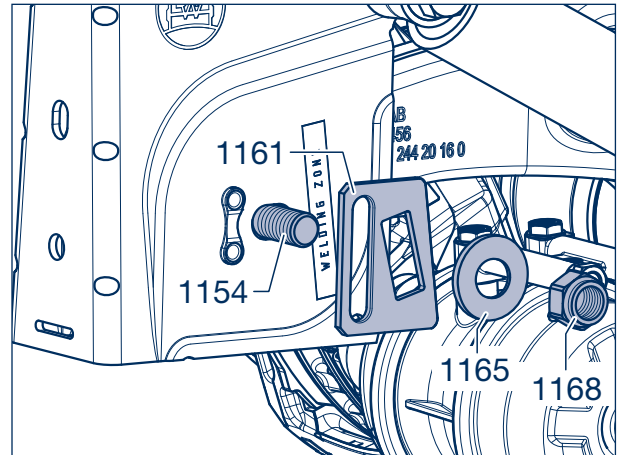

Figure 7



Repair note:

Pay particular attention to the correct position of the adjusting plate (1161) on the torsion protection (arrows) of the air suspension hanger brackets!

The square on the spring bolt head (torsion protection) must sit in the slot of the adjusting plate.

Tighten lock nut only after axle alignment check (see Chapter 15).

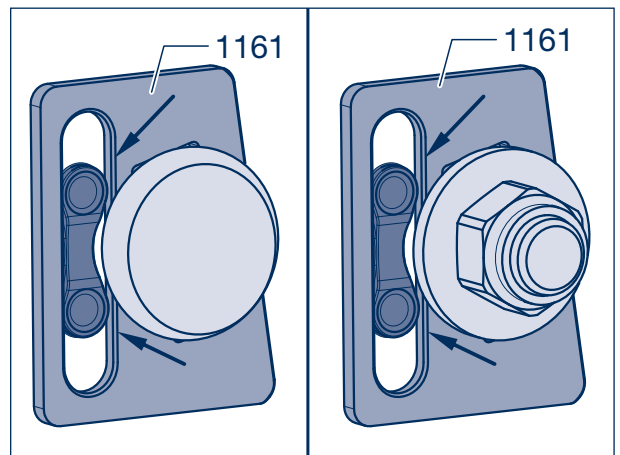

Figure 8

- [13] Install lower shock absorber eye on trailing arm (1000). Tighten bolt (1324, SW 36) to the specified tightening torque of **420 Nm** (390 - 460 Nm).

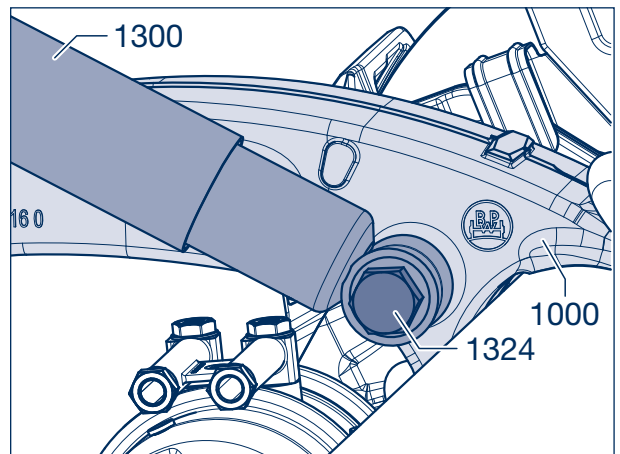

Figure 9

8 Replacing trailing arm

- [14] On version with bolted brace, fasten gusset plate to top of cross-member with at least three M 16 bolts.
- [15] Install screw (1570, M 18 x 1.5) at bottom of spring bolt and screw on nut (1571, SW 27).
- [16] Tighten nut to a specified tightening torque of **420 Nm** (390 - 460 Nm).
- [17] Install air bag beam, see Chapter 7.2.

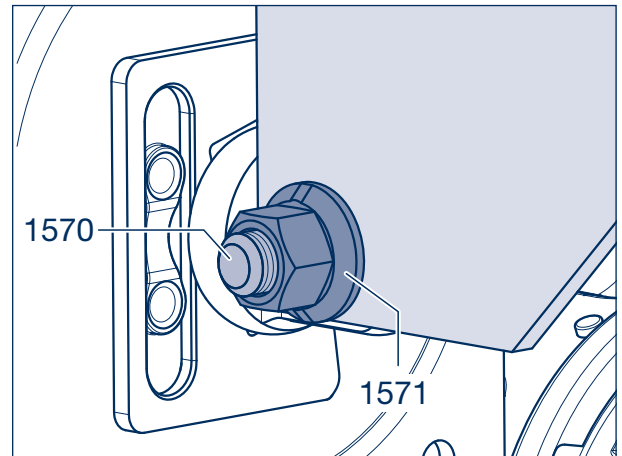

Figure 10

Disassembling and installing axle 9

9.1 Disassembling axle

- [1] Prevent the vehicle from rolling away.
Release the service and parking brake.
- [2] Measure and note distances (A) and (X) from top of axle beam and top of air bag beam to bottom of frame.
- [3] Remove both air bag beams, see Chapter 7.1.
- [4] Unscrew air hoses from brake cylinder.
Remove parking brake cables if fitted.
- [5] Loosen all cable connections to axle (brake pad wear sensing, ABS, etc.).
- [6] Carefully lower and remove the axle.

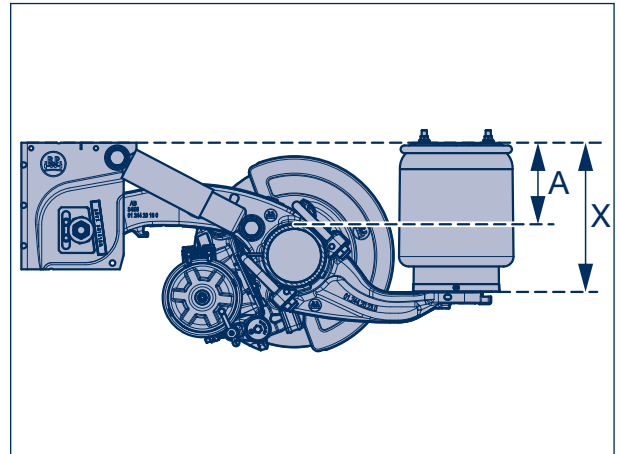

Figure 1

9.2 Installing axle



Note!

If the axle to be removed is re-installed later, mark the position of the air bag beam (1030) and trailing arm (1000) and/or the spring centre on the axle beam with a coloured marker (see page 21, work step [8]).

- [7] Position axle on vehicle jack (low-lift platform truck) to prevent accidents, slide below frame and lift until top of axle beam reaches position (A) measured in work step [2] and is in contact with trailing arm on both sides (arrows).

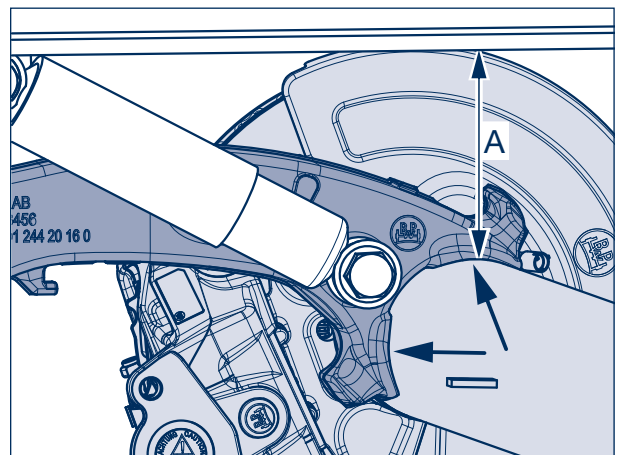

Figure 2

Axle radial alignment - disc brake

- [8] Insert one screw M 24, e.g. shock absorber fixing screw, into the trailing arm from outside.
- [9] Determine dimension between lower surface of the screw and centre cap of the reset shaft.

Clearance Y: for TS2 3709: 120 mm - 125 mm
for TS2 4309: 130 mm - 135 mm

If necessary, rotate the axle until the clearance is within the specified tolerance.

- ➡ Continue with work step [11].

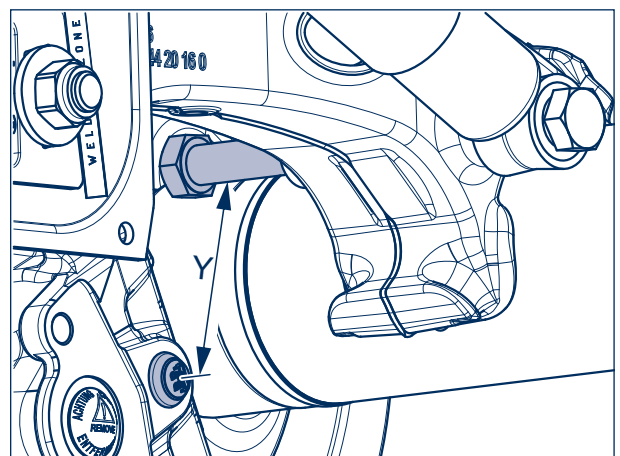

Figure 3

9 Disassembling and installing axle

Axle radial alignment - drum brake

- [8] Take lower shock absorber fixing screw (1324, SW 24) out of the trailing arm slightly.
- [9] Determine shortest distance Y between lower surface of the screw and surface of the brake camshaft.

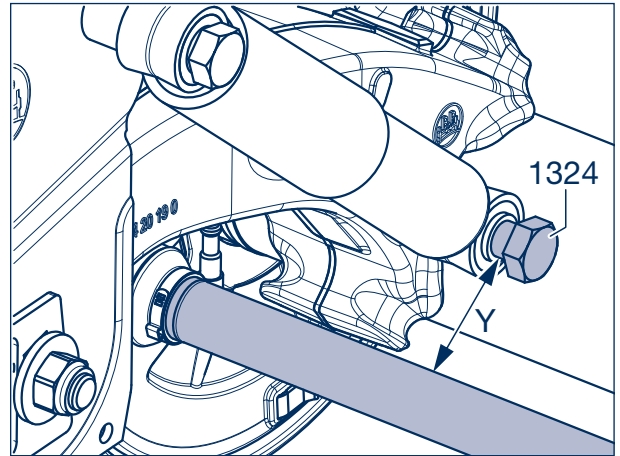

Figure 4

Clearance Y for SN 4218 with:

- "R" booster bracket (brake position 8°): 65 - 70 mm
- "S" booster bracket (brake position 16°): 83 - 88 mm

If necessary, rotate the axle until the clearance is within the specified tolerance.

- [10] Tighten lower shock absorber fixing screw to a tightening torque of **420 Nm** (390 - 460 Nm).

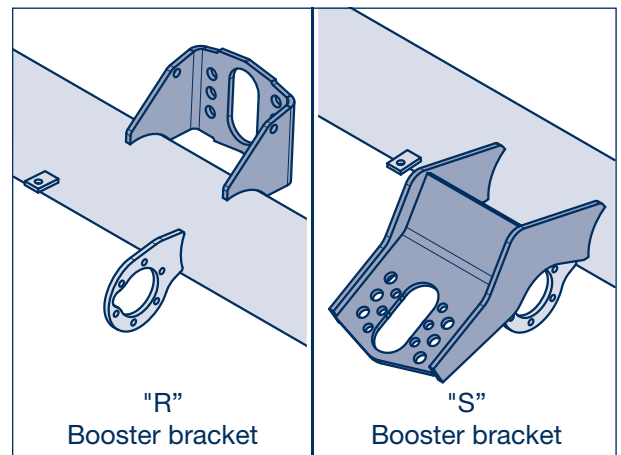

Figure 5

- [11] Pre-mount new upper spring U-bolt (1050) on air bag beam (1030).



Repair note!
The thread of the spring U-bolts must not be greased.

- [12] Position new washers (1055) and screw on new lock nuts (1057) by hand.
- [13] Hook air bag beam with spring U-bolt mounted into bracket on trailing arm (1000).

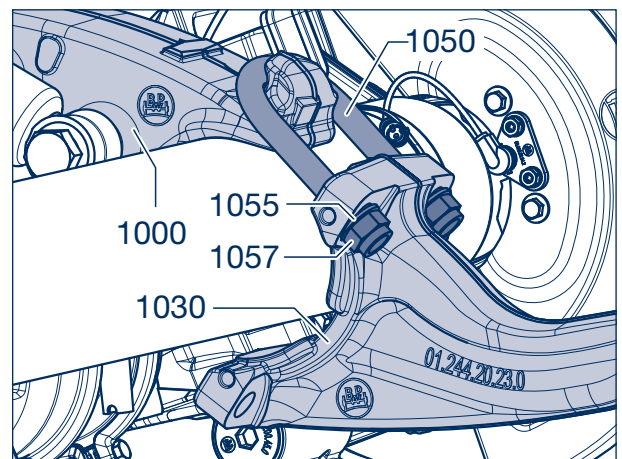

Figure 6

- [14] Install new lower spring U-bolt (1050), position new washers (1055) and screw on new lock nuts (1057).

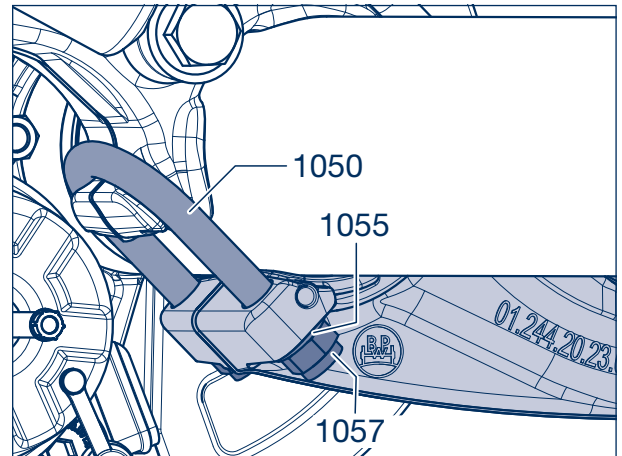

Figure 7

Installing a removed axle:

- [15] Align trailing arms (1000) and air bag beam (1030) with the spring centre markings (arrows) (before carrying out work step [7]).

Installing a new axle:

- [15] Align trailing arms (1000) and air bag beam (1030) to dimensions A and X (see work step [2]). The radial alignment of the axle must not be changed in the process.
- [16] Gently tighten lock nuts (1057, SW 30) - on each spring U-bolt - until all components make uniform contact.

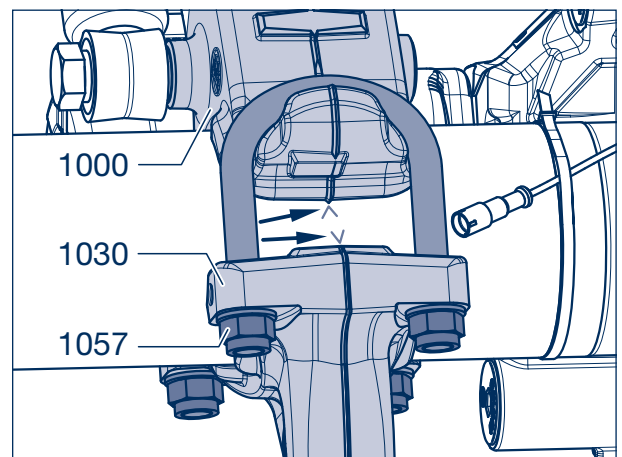

Figure 8



Repair note!

Never tighten lock nuts just on one side, this will prevent unequal tension.

- [17] Check position of trailing arm (1000) and of air bag beam (1030). Measure distance from centre of cast part (mould parting line) to brake drum / brake disc, equalise distances, if necessary.
Permissible tolerance: ± 2 mm

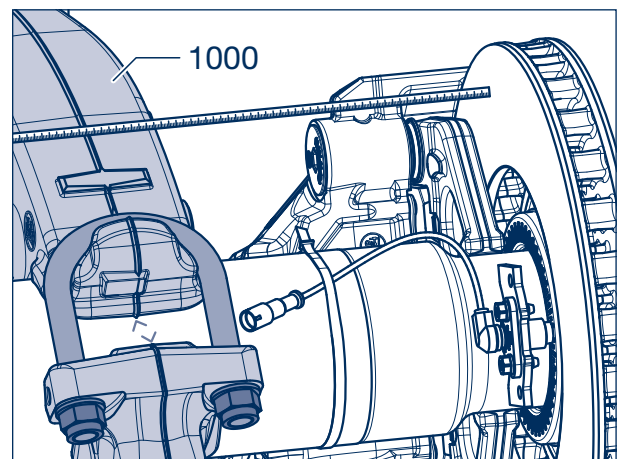

Figure 9

9 Disassembling and installing axle



Repair note!

During assembly, make sure the spring U-bolts (1050) and cast components (1000, 1030) move freely towards the axle beam, centre if necessary.

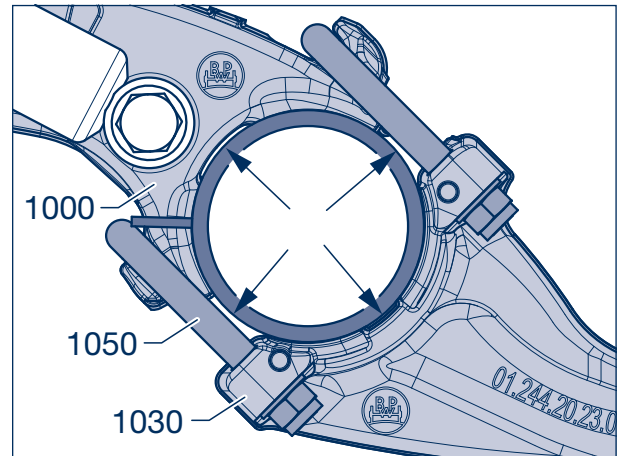

Figure 10

- [18] Tighten lock nuts (1057, SW 30) to tightening torque of 200 Nm diagonally in sequence 1, 2, 3, 4 using torque wrench.

While tightening always ensure that the clearance between the U-bolts and axle beam radii, as well as the position of the cast parts (trailing arms and air bag beam) is maintained on the axle beam (coloured marking spring centre, Figure 7).

- [19] Measure distance X (Figure 12). This must coincide with the value noted in work step [2]. Tolerance +/- 1 mm.

If necessary loosen spring U-bolt slightly, correct position and retighten.

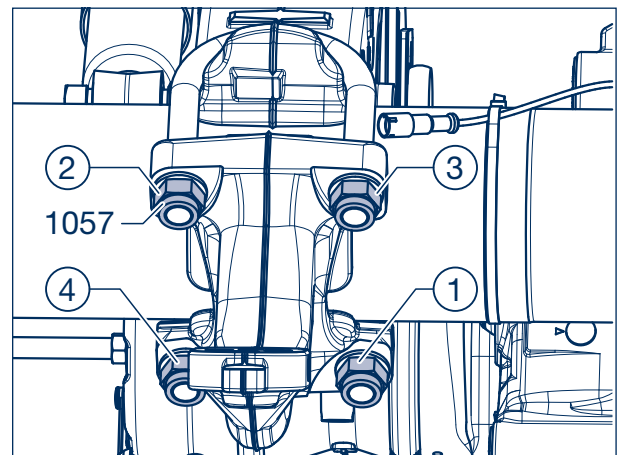

Figure 11

- [20] Tighten all lock nuts to a tightening torque of 350 Nm and then to 450 Nm.
- [21] Finally tighten all lock nuts by turning an additional 90°.



Repair note!

After tightening, an exposed thread must be visible at every spring U-bolt.

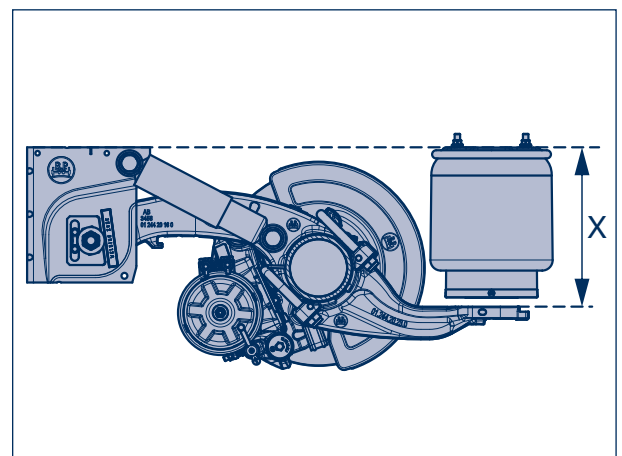

Figure 12

- [22] Clean contact surfaces on air bag and air bag beam (1030).
- [23] Install lower air bag beam attachment.
Install locking screw(s) (1224, SW 22) (depending on version of air bags) and tighten to the specified tightening torque.

Lower attachment with two screws:
M 16 (SW 22) M = 230 - 300 Nm

Lower attachment with central screw:
M 16 (SW 22) M = 300 Nm

- ☞ If the air bag has been removed completely, see Installing air bags, Chapter 11.2.

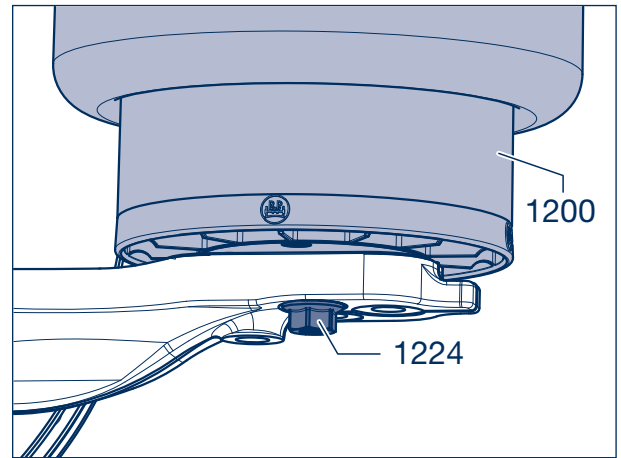

Figure 13

- [24] Lower axle and remove vehicle jack.
- [25] Inflate air bags by setting rotary disc valve / change-over valve lever for air suspension to "Lift".

On air suspensions without rotary disc valve / change-over valve, actuate the lever on the air suspension valve until air bags are filled with air.
- [26] Remove vehicle supports.

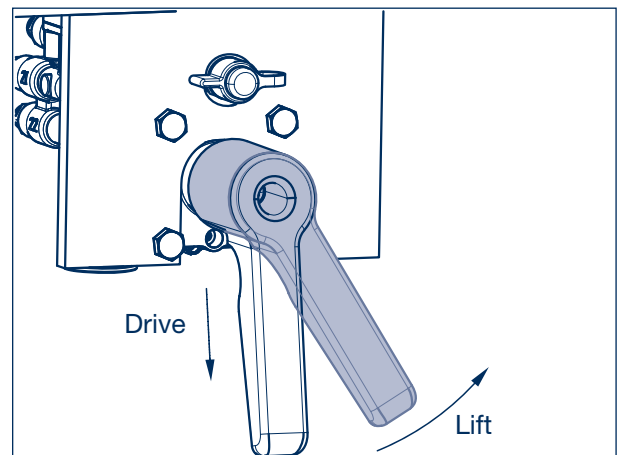

Figure 14

- [27] Lower vehicle, deflate air bags to driving position by setting rotary disc valve / change-over valve lever on air suspension to "Drive".
- [28] On air suspensions without rotary disc valve / change-over valve, screw nut (2) for air suspension valve steering device (1) onto axle.
The vehicle is automatically reset to the ride height.

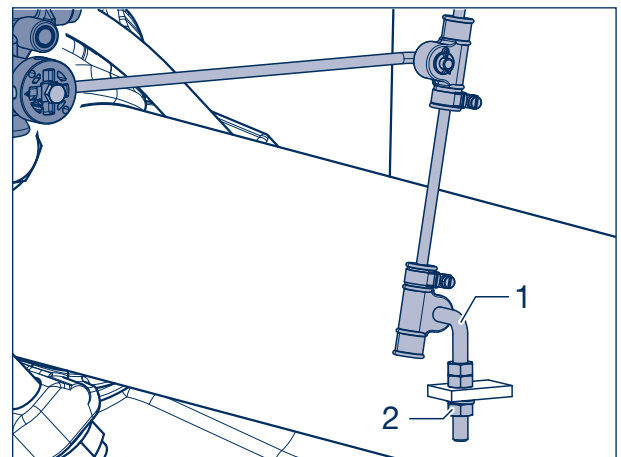

Figure 15

10 Replacing rubber-steel bush in trailing arm

10.1 Removing rubber-steel bush

Check the rubber-steel bush (1005) for wear. To do this, measure the distance from the bottom edge of the plastic wearing plate (1525) to the trailing arm (1000) on a fully laden vehicle. The bush must be replaced in case of a measurement of $X > 30$ mm.

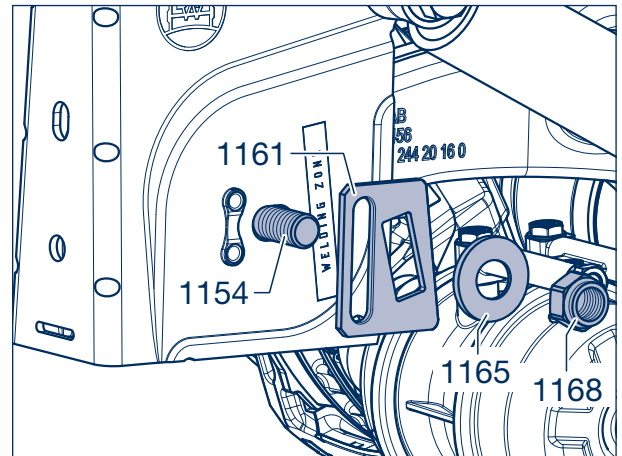
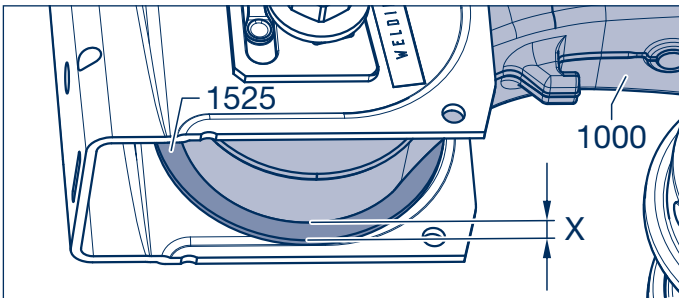

Figure 1

It is not necessary to detach the trailing arm (1000) from the axle to replace the rubber-steel bush (1005).

- [1] Support axle to prevent accidents.
- [2] Remove lock nut (1168, SW 36) from the spring bolt (1154).
- [3] Remove washer (1165) and adjusting plate (1161).
- [4] Drive spring bolts (1154) out of hanger brackets (1511) and trailing arm bushes (1005).
- [5] Press trailing arm eye out of hanger bracket; lower axle slightly if necessary.
- [6] Remove wear washers (1525) from rubber-steel bush (1005).

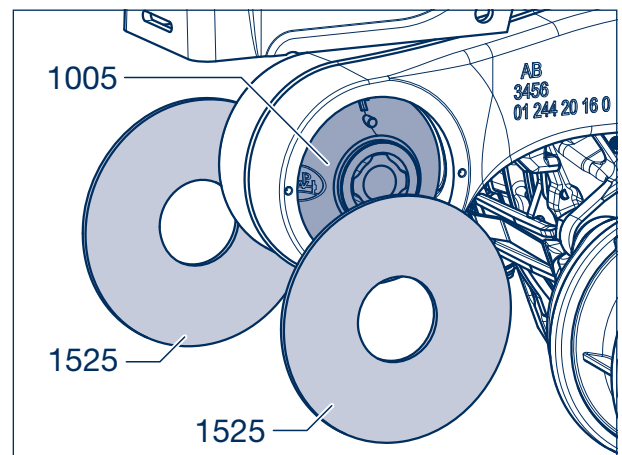

Figure 2



Repair note!

The installation and removal tool (BPW No.: 99.00.000.9.69) does not have to be dismantled, see Page 6.

- [7] The threaded rods (6) must be loosened far enough so that the assembly can be slipped over the head of the suspension arm (1000) from the front.
- [8] Tighten the threaded rods gently so that the alignment funnel (5) is resting on the smaller centring diameter of the puller plate (4).

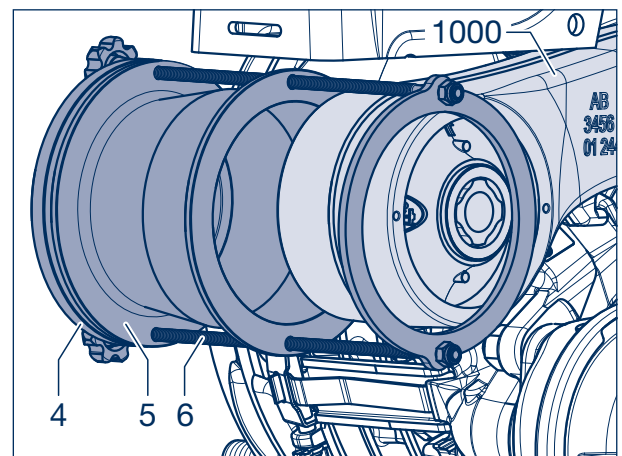

Figure 3

- [9] Generously coat the tension rod (10) and nut (1, SW 36) with heavy-duty lubricating and mounting grease (e.g. STABURAGS NBU30 PTM).
- [10] Attach the washers (9) and the installation sleeve (8) to the tension rod.
- [11] Screw the preassembled tension rod in the nut (1, SW 36) until it makes contact with the rubber-steel bush (1005).

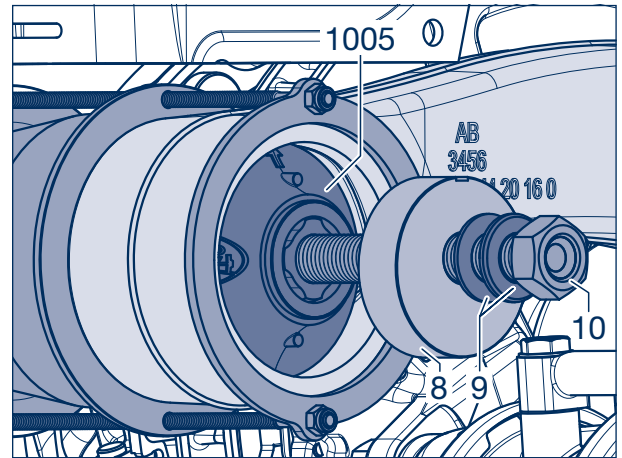

Figure 4

**Attention!**

Do not use an impact wrench. Use of an impact wrench reduces the life expectancy of the spindle considerably; it is even possible for the threaded parts to fail!

- [12] Pull the rubber-steel bush (1005) over the tension rod (10) out of the trailing arm (1000).
- [13] Unscrew the assembled tension rod (10), loosen threaded rods (6) and remove device with rubber-steel bush.

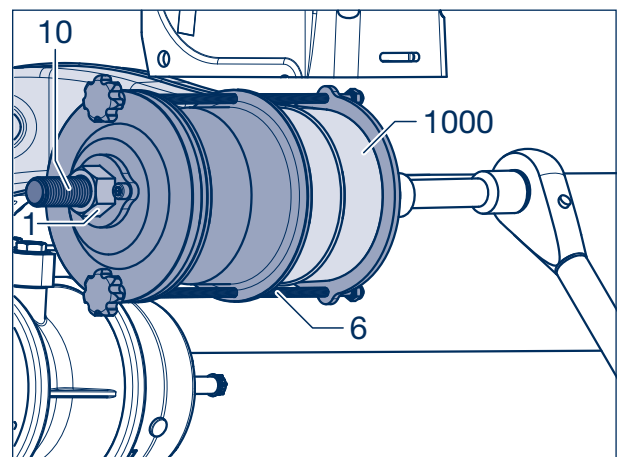

Figure 5

- [14] Remove plugs (1015) from trailing arm (1000) with screwdriver, if necessary with aid of hammer.
- [15] Clean contact surfaces in trailing arm.
- [16] Clip in new plugs.

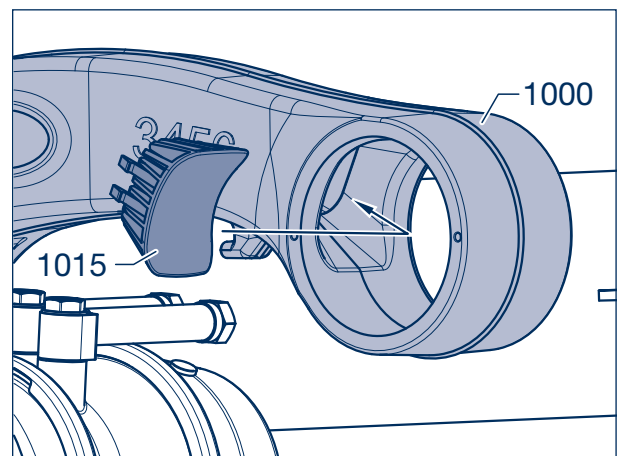

Figure 6

10 Replacing rubber-steel bush in trailing arm

10.2 Installing rubber-steel bush



Repair note!

The rubber-steel bush (1005) must always be assembled in the direction of travel, as viewed from the right side.

- [17] Position the mask (20) laterally to the right on the trailing arm (1000). To do this, use the two short protruding pin ends in the two indentations in the face of the trailing arm.
- [18] Using a suitable pin, attach the 'top' marking inside the fork of the mask (arrow) onto the trailing arm.

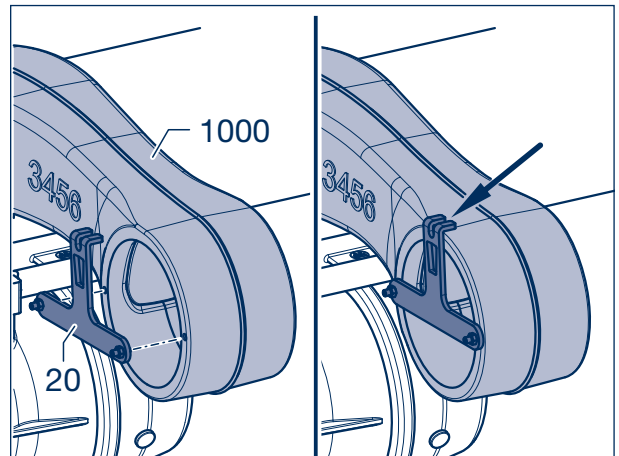

Figure 7



Repair note!

To aid assembly of the rubber-steel bush (1005), the lateral surface, the hole in the trailing arm (1000) and the inside of the alignment funnel (5) must be coated with tyre fitting paste.

- [19] The threaded rods (6) must be loosened far enough so that the assembly can be slipped over the head of the trailing arm (1000) from the front. Alignment funnel (5) sits snugly at the ring (7).
- [20] Mount the installation device so that the centring of the puller plate (4) is positioned in the trailing arm eye.
- [21] Tighten the threaded rods (6) gently.
- [22] Generously coat the tension rod (10) and nut (1, SW 36, see Fig. 5) with a heavy-duty lubricating and mounting grease (e.g. STABURAGS NBU30 PTM).
- [23] Attach the washers (9) and the installation sleeve (8) to the tension rod.
- [24] Insert the rubber-steel bush (1005) in the alignment funnel (5) with the arrow pointing up.

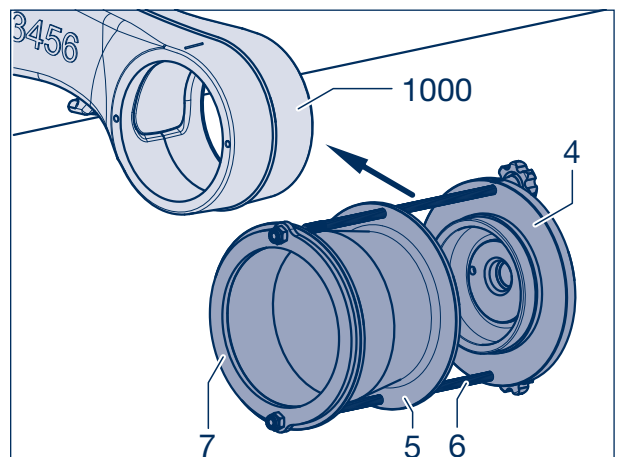

Figure 8



Repair note!

If there are sprue nubs on the rubber-steel bush, they must be mounted so that they are pointing towards the alignment funnel.

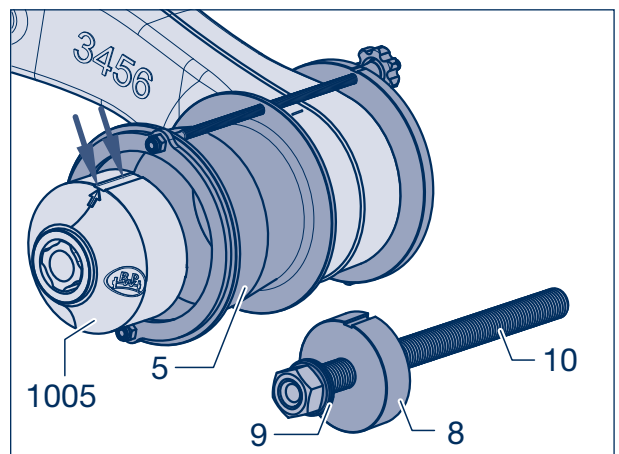

Figure 9

- [25] Screw the preassembled tension rod in the nut (1, SW 36) until it makes contact with the rubber-steel bush (1005).

Alignment



Repair note!

When aligning the installation device to the trailing arm (1000), all the relevant parts markings must point **upwards** and be aligned.

- red groove of the puller plate (4)
- rod (6) over the manually applied marking on the trailing arm (see working step [18])
- marking rubber steel bush (1005)
- red groove of the puller plate (8)

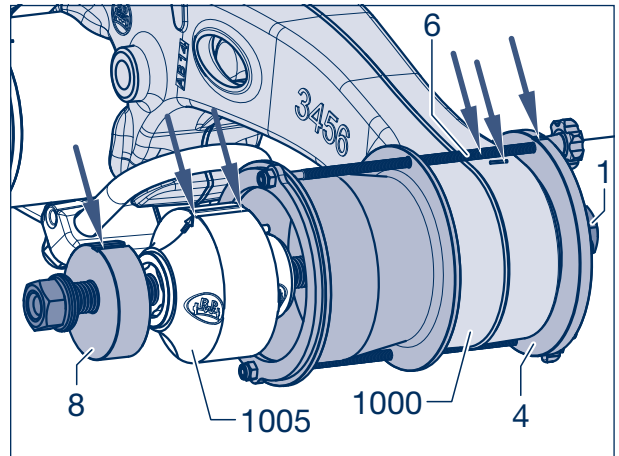

Figure 10



Attention!

Do not use an impact wrench. Use of an impact wrench reduces the life expectancy of the spindle **considerably**; it is even possible for the threaded parts to fail!

- [26] Set tight the rubber-steel bush (1005) over the tension rod (10, SW 36) in the trailing arm (1000) until it makes contact with the puller plate (4). When setting tight, the device can centre slightly in a radial direction if the threaded rods (6) are not tightened too much.

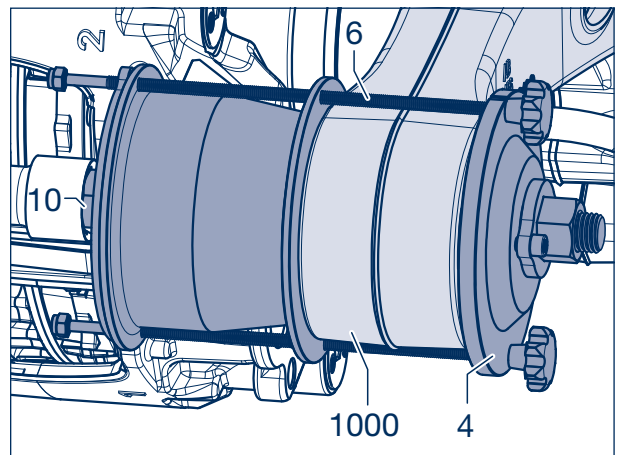

Figure 11

- [27] Unscrew the assembled tension rod (10), loosen threaded rods (6) and remove device.

- [28] Check the fit of the rubber-steel bush (1005).



Note!

If the bush sits mis-aligned or off-centre in the eye of the trailing arm, it can be readjusted using a long bar. To do this, insert the bar through the opening in the bush and lever the bush into the required position.

The adjustment process must be finished within approx. 10 minutes to ensure the tyre fitting paste is not dried yet.

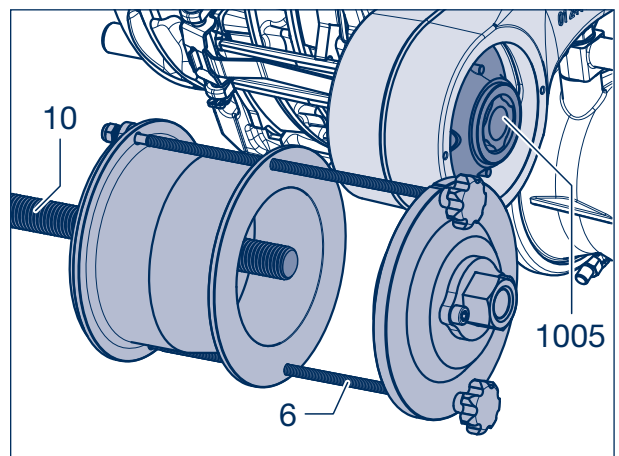

Figure 12

10 Replacing rubber-steel bush in trailing arm

- [29] Check the angular position of the rubber-steel bush (1005). To do this, place the mask (20) on the bushing countersink and position the two long protruding pin ends in the two indentations in the face of the trailing arm.

If the marking on the bush ("up" arrow) can be seen within the recess (arrow), the position is correct (permissible angular tolerance $\pm 5.5^\circ$). Where appropriate, remove the bush and set tight again.

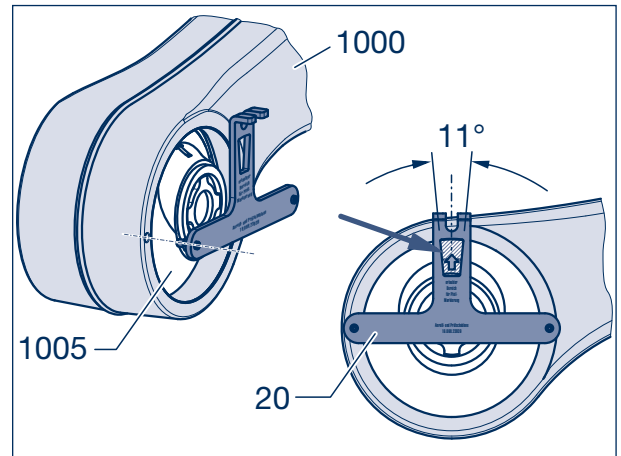

Figure 13

- [30] Install wear washer (1525) on rubber-steel bush.

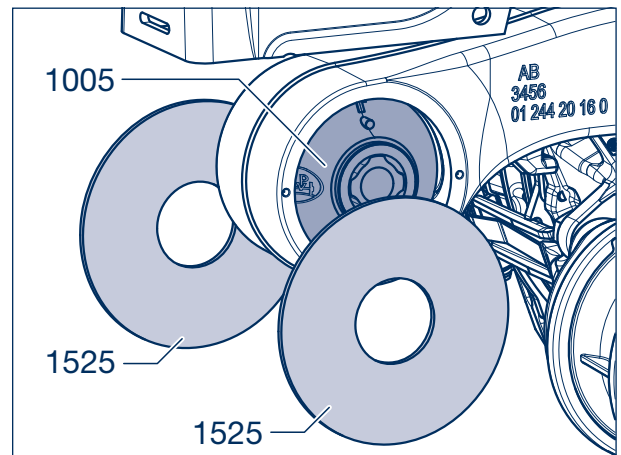

Figure 14

- [31] Insert trailing arm into support.

- [32] Install spring bolt (1154, SW 36), see Chapter 8, work step 10 - 12.

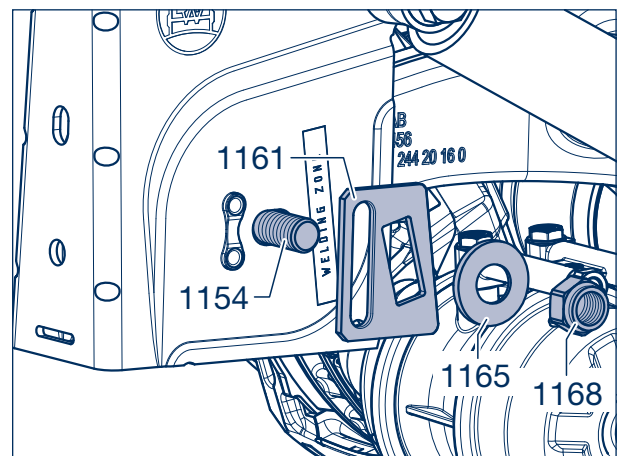

Figure 15

Disassembling and installing air bags 11

11.1 Disassembling air bags

- [1] Inflate air bag (1200) as much as possible using the rotary slide valve/change-over valve.
- [2] Support vehicle to prevent accidents, e.g. place suitable distance piece between vehicle frame and trailing arm.
- [3] Deflate air bags.

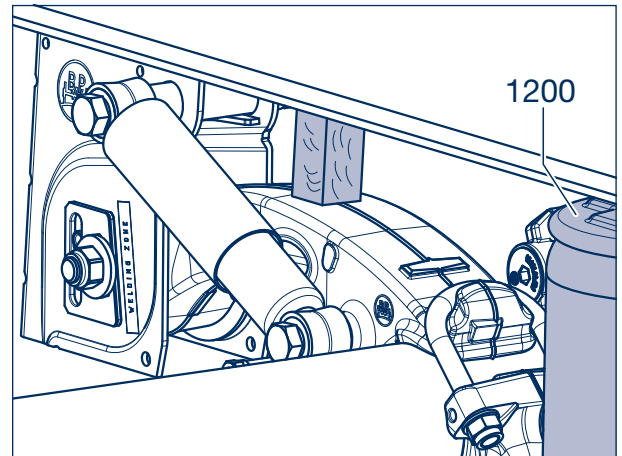

Figure 1

Air bag with central bolt

- [4] Use an impact driver to remove the locking screw (1224, SW 22).

 Continue with work step [5].

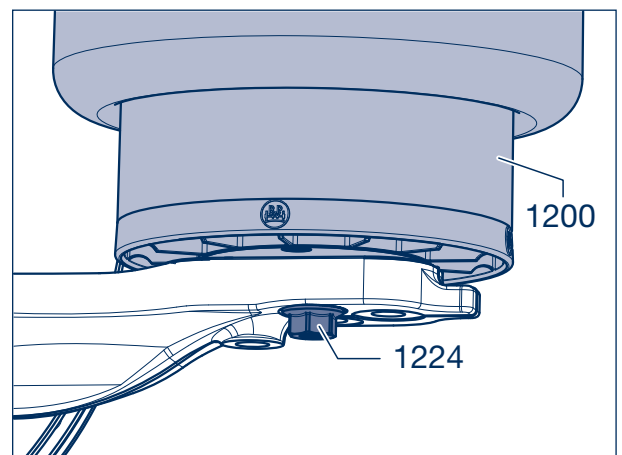

Figure 2

Air bag with universal plate

- [4] If the air bags (1200) are to be disassembled after removal, loosen centre hexagon screw (1222, SW 22) to facilitate disassembly.

Remove locking screws (1224, SW 22).



Note!
If the hexagon screw (1222) is located above the trailing arm, it can be loosened only after removal of the air bags.

 Continue with work step [5].

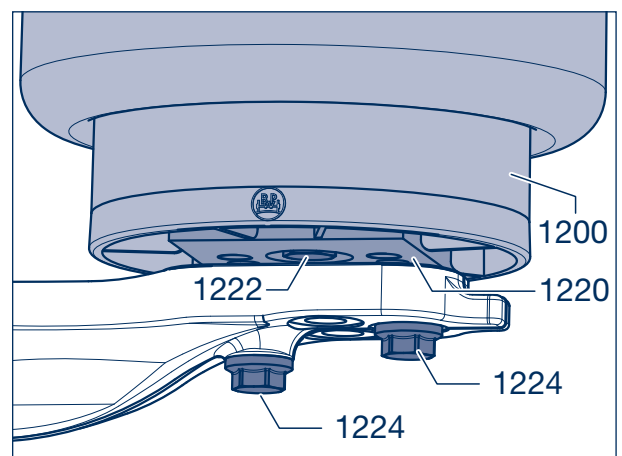

Figure 3

11 Disassembling and installing air bags

Combi air bag

- [4] Remove locking screws (1224, SW 22). Remove hanger bracket (1212) from air bag beam (1030).

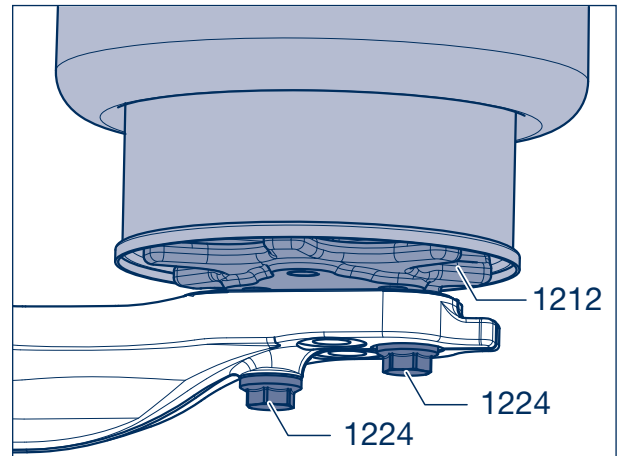

Figure 4

- [5] Unscrew union nut (2) from screwed joint (1) and detach air hose (3) from screwed joint.

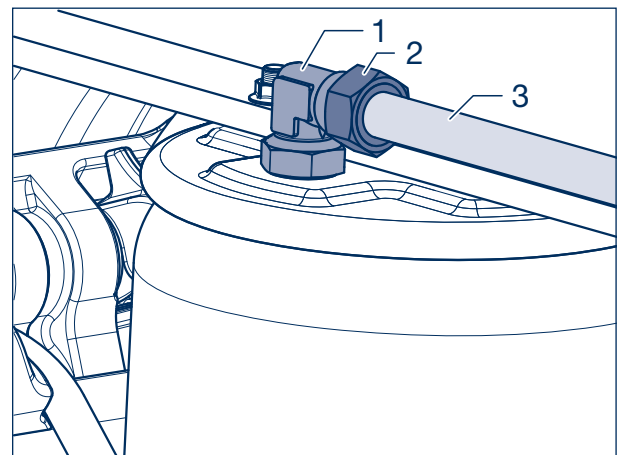

Figure 5

- [6] Remove both lock nuts (1240, SW 17) from the bolts.

- [7] Remove air bag (1200).

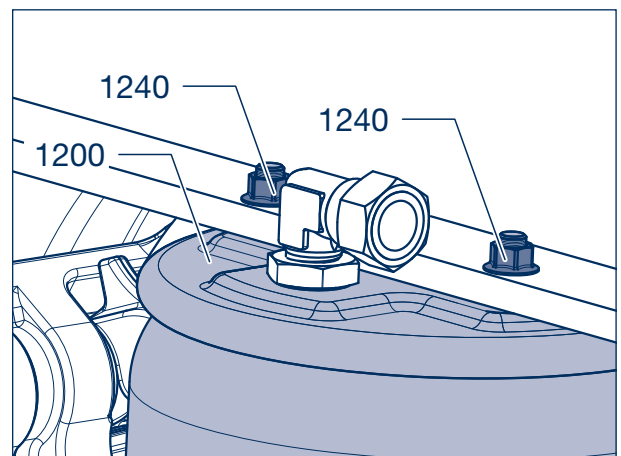

Figure 6

- [8] If necessary loosen counter nut (2) on screwed joint (1) and unscrew screwed joint from air bag (1200).

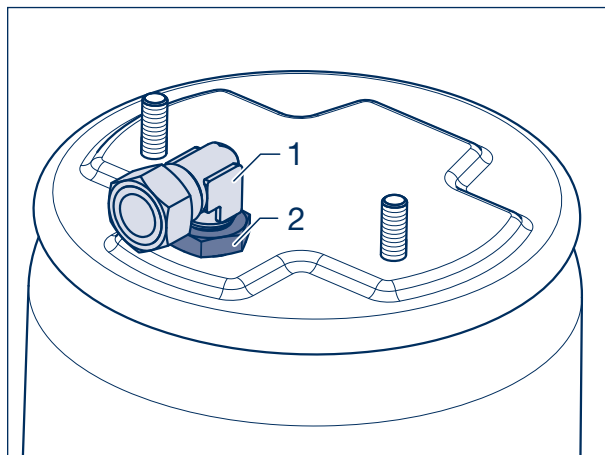

Figure 7

11.2 Installing air bags

- [9] Slide pressure ring (3) over threads on screwed joint (1) with smooth surface forward, then install new O-ring (4).
- [10] Insert screwed joint into air bags, do not tighten the counter nut (2) yet.

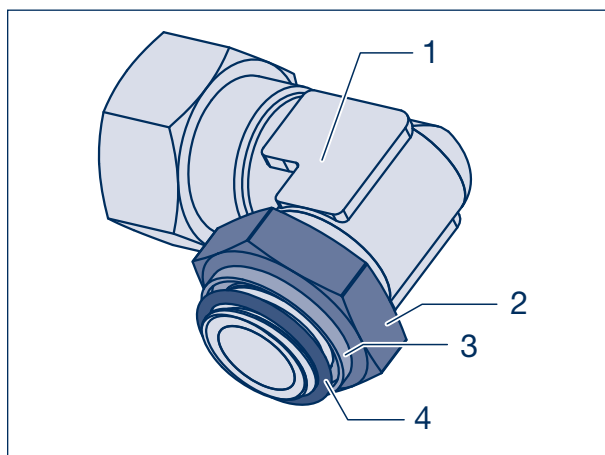

Figure 8

- [11] Clean contact surfaces on air bag and air bag beam (1030).

Air bag with central bolt

- [12] Position air bag (1200) on air bag beam (1030).
- [13] Screw in M 16 locking screw (1224, SW 22) and tighten to the specified tightening torque of $M = 300 \text{ Nm}$.

☞ Continue with work step [14].

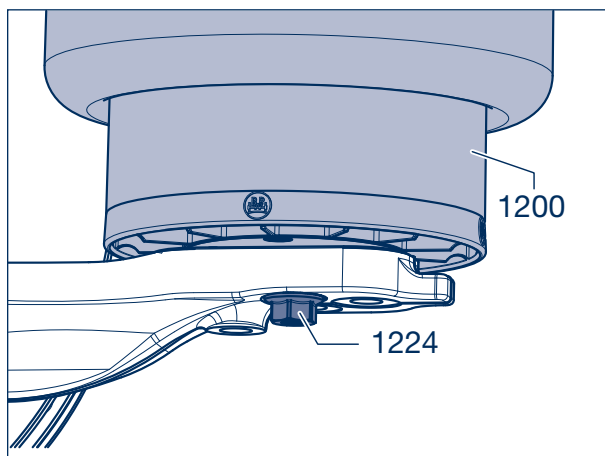

Figure 9

11 Disassembling and installing air bags

Air bag with universal plate

- [12] Position air bag (1200) on air bag beam (1030).
- [13] Insert M 16 locking screw (1224, SW 22) and tighten to the specified tightening torque of $M = 230 - 300 \text{ Nm}$.



Note!
If the hexagon screw (1222, SW 22) was loosened during disassembly, check the specified torque of $M = 230 \text{ Nm}$.

☞ Continue with work step [14].

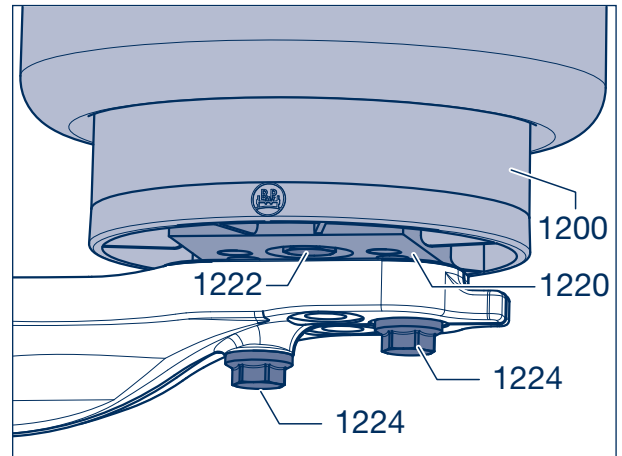

Figure 10

Combi air bag

- [12] Place hanger bracket (1212) in correct position on air bag beam (1030).
- [13] Insert M 16 locking screw (1224, SW 22) and tighten to the specified tightening torque of $M = 230 - 300 \text{ Nm}$.

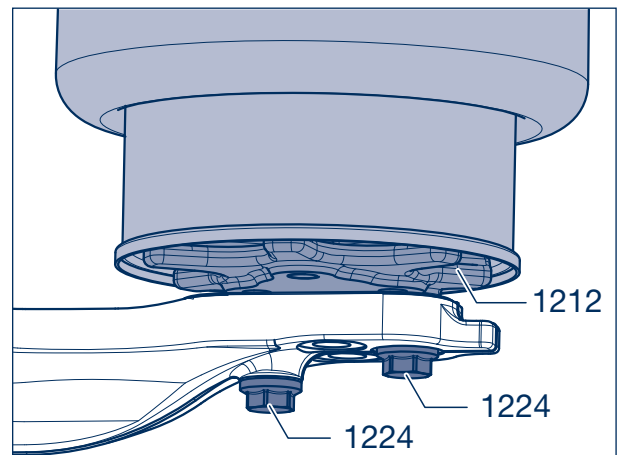

Figure 11

- [14] Inflate air bags (1200) slightly, while simultaneously inserting the two bolts for the upper plate into the bore holes provided for this purpose on the vehicle frame.
- [15] Screw the two lock nuts (1240, SW 17) onto the bolts and tighten to the specified tightening torque of 66 Nm .

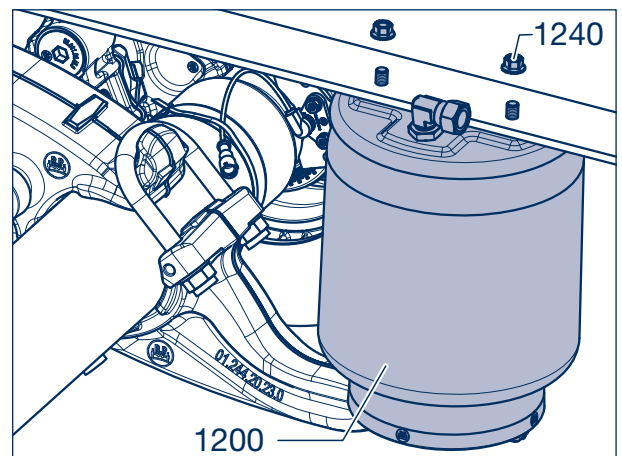

Figure 12

- [16] Screw union nut (2) for air hose (3) onto screwed joint (1), then tighten counter nut (4).
- [17] Check compressed air system for leakage and functionality.

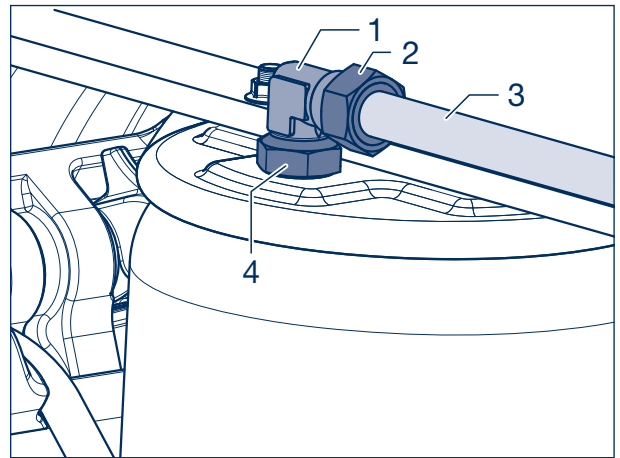

Figure 13

11 Disassembling and installing air bags

11.3 Dismantling and assembling air bag with central bolt



Repair note!

As of August 2019, it will no longer be possible to replace individual components of central air bags 30 and 30K. The air bag has to be replaced in its entirety.

Dismantling

- [1] Disassemble air bag, see Chapter 11.1.
- [2] Feed compressed air into the bore hole for the air connection until the air bag (1205) is completely extended.
- [3] Pull plastic piston (1210) off the bolt (1215).
- [4] Screw bolt (1215, SW 32) off the air bag.

Assembly

- [5] Tighten bolt (1215, SW 32) on air bag (1205) to a tightening torque of 130 Nm.
- [6] Install plastic piston (1210) on bolt (1215).

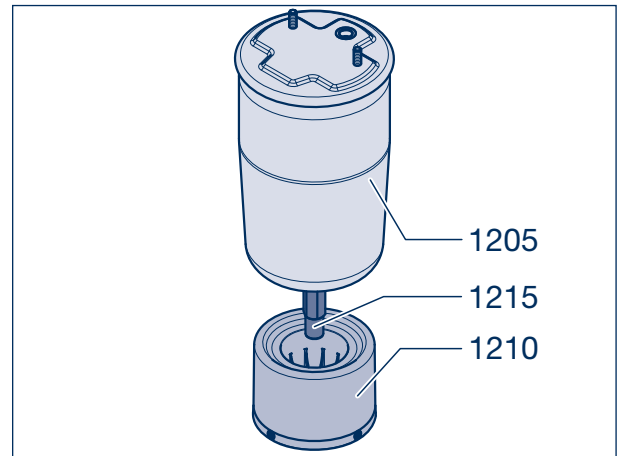

Figure 14

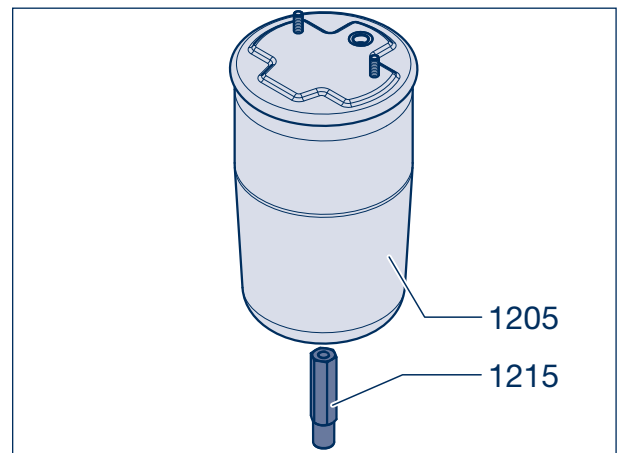

Figure 15

11.4 Dismantling and assembling air bag with universal plate

Dismantling

- [1] Disassemble air bag, see Chapter 11.1.
- [2] Feed compressed air into the bore hole for the air connection until the air bag (1205) is completely extended.
- [3] Remove locking screw (1222, SW 22) with impact wrench.

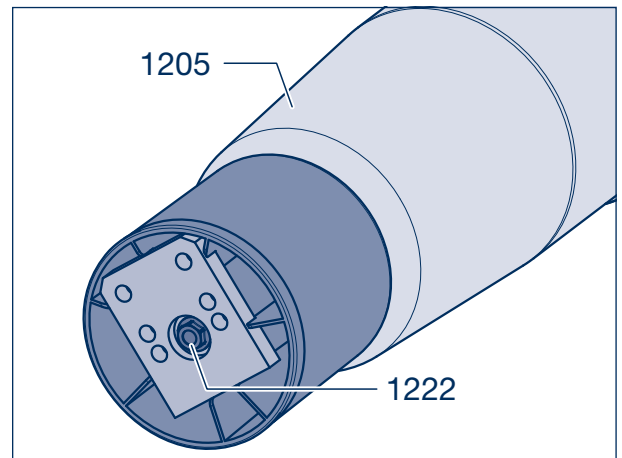

Figure 16

- [4] Remove plate (1220) and plastic piston (1210).
- [5] Screw off threaded sleeve (1215, SW 24).

Assembly

- [6] Screw threaded sleeve (1215, SW 24) onto air bag (1205) to a tightening torque of 130 Nm.

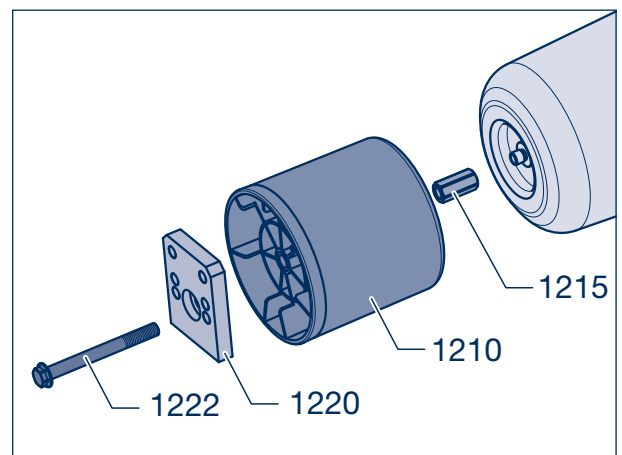

Figure 17

- [7] Position plate (1220) in plastic piston (1210) and gently tighten locking screw (1222, SW 22) onto threaded sleeve (1215).
- [8] Align mounting points with one another so that air bag is not turned to wrong position after installation.
- [9] Tighten locking screw (1222, SW 22) to the specified tightening torque of 230 - 300 Nm.

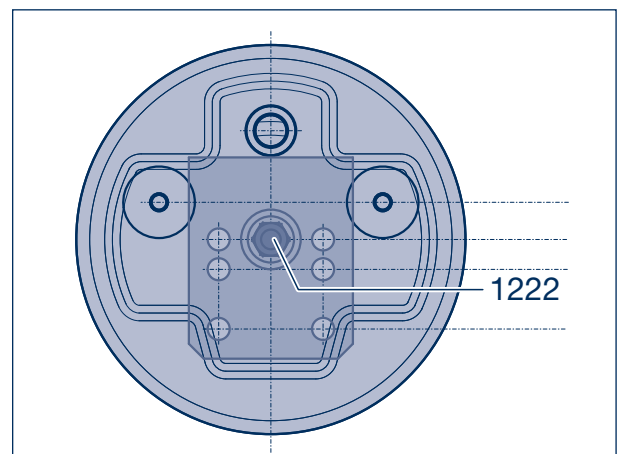

Figure 18

11 Disassembling and installing air bags

11.5 Dismantling and assembling Combi air bag

Dismantling

- [1] Disassemble air bag, see Chapter 11.1.
- [2] Feed compressed air into the bore hole for the air connection until the air bag (1205) is completely extended.
- [3] Loosen nut with hexagonal recess (1218, SW 19) using impact wrench and unscrew.

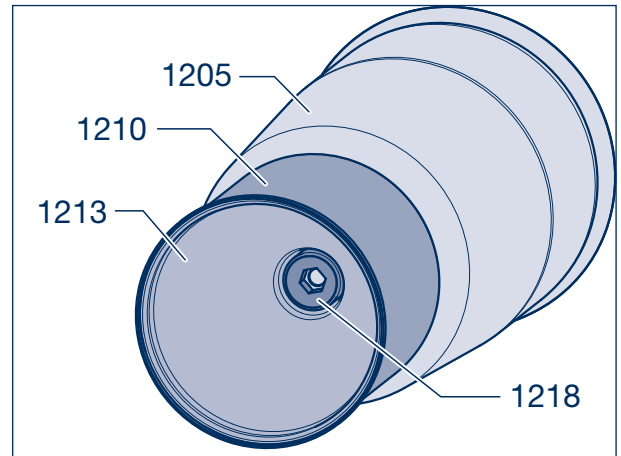

Figure 19

- [4] It is then possible to remove the two pistons (1210, 1213).

Assembly

- [5] Install piston (1213) in piston (1210).

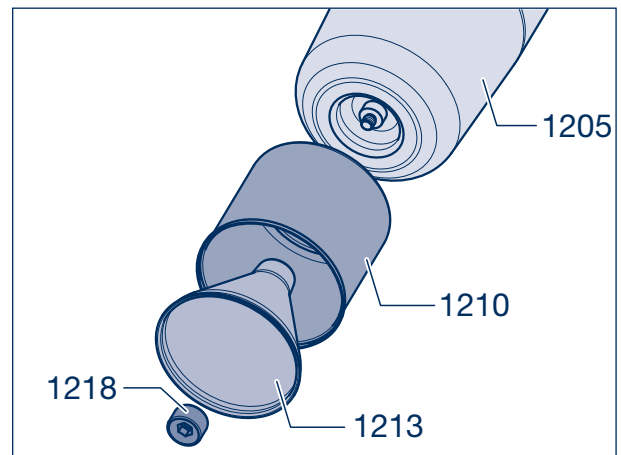

Figure 20

- [6] Coat threads (arrow) on air bag (1205) with thread-locking adhesive, e.g. Loctite.
- [7] Assemble the pistons on to air bag with nut (1218, SW 19).
Tightening torque: $M = 130 \text{ Nm}$

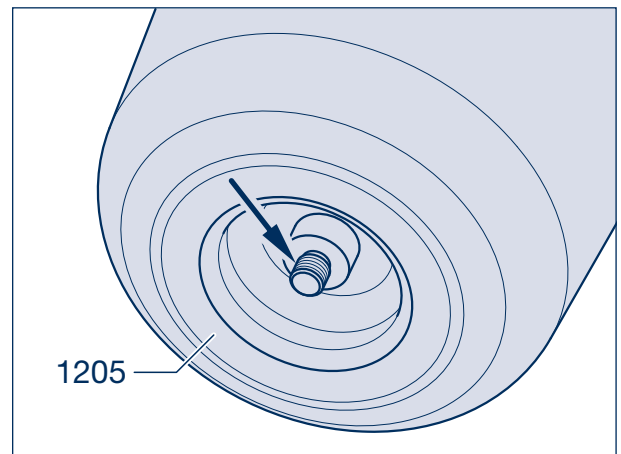

Figure 21

Disassembling and installing shock absorbers 12

Disassembly

- [1] Support axle and vehicle to prevent accidents.
- [2] Remove locking screw (1324, SW 36) from lower shock absorber attachment on trailing arm (1000).
- [3] Remove lock nut (1330, SW 36) from hexagon screw (1315) on upper shock absorber attachment.
- [4] Secure shock absorber (1300) from falling down and pull hexagon screw (1315) out of hanger bracket.

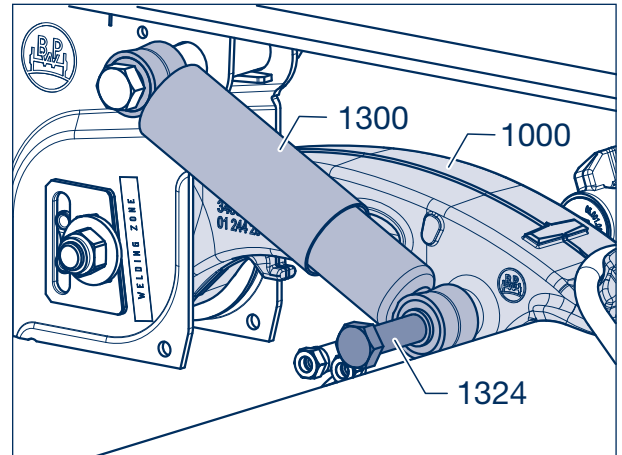

Figure 1

Installing



Repair note!

- Replace shock absorbers in pairs or per axle only.

- Install shock absorber with the protective sleeve facing up.

- [5] Coat hexagon screw (1315) for shock absorber attachment lightly with grease (thread and bearing points).
- [6] Insert hexagon screw (1315) from inside to outside into the shock absorber (1300) and into the air suspension hanger bracket tube (1511).
- [7] Screw on lock nut (1330, SW 36) loosely.
- [8] Install shock absorber (1300) on trailing arm (1000) using hexagon screw (1324, SW 36).
- [9] Tighten hexagon screw (1324) and lock nut (1330) to the specified tightening torque of **420 Nm** (390 - 460 Nm).

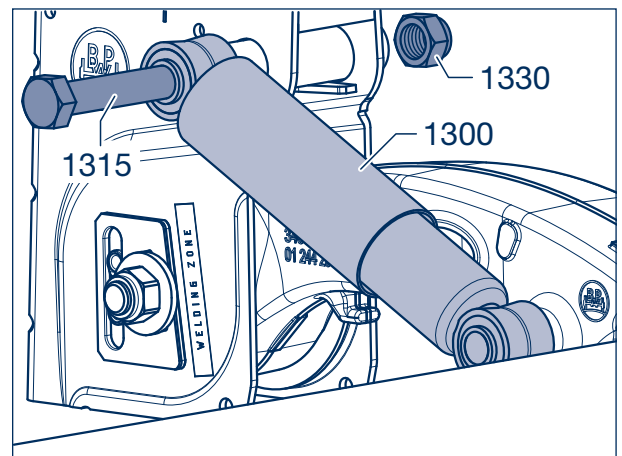

Figure 2

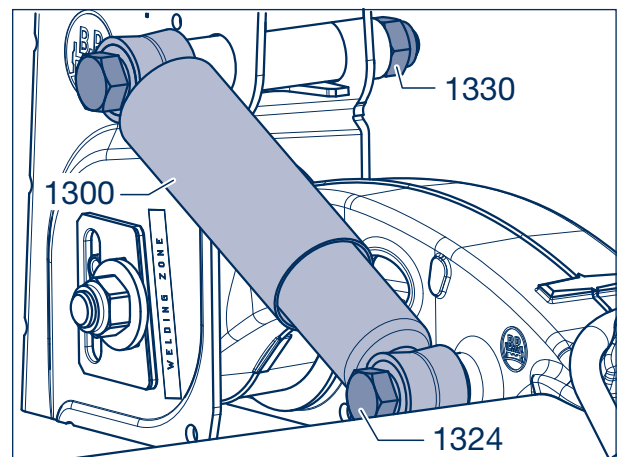

Figure 3

12 Disassembling and installing shock absorbers

12.1 Replacing bushes in shock absorber

Disassembly

- [1] Remove shock absorber (1300).
- [2] Align shock absorber eye beneath press and press out steel bush (1303) with suitable tool.
- [3] Then press out rubber bush (1304).



Repair note!
When pressing out, do not damage shock absorber or shock absorber eye.

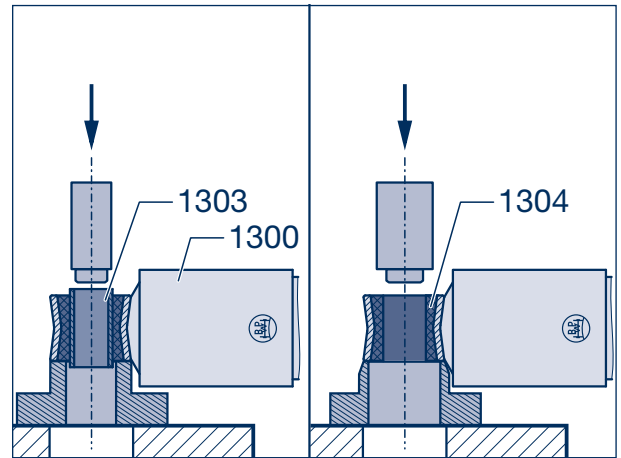

Figure 4

Installation

- [4] Coat rubber bush (1304) and steel bush (1303) with 50% soap solution.
- [5] Press rubber bush into stop in shock absorber eye.
- [6] Position steel bush (1303) on a suitable mandrel
- [7] Turn shock absorber 180°. Press in steel bush with drift punch.

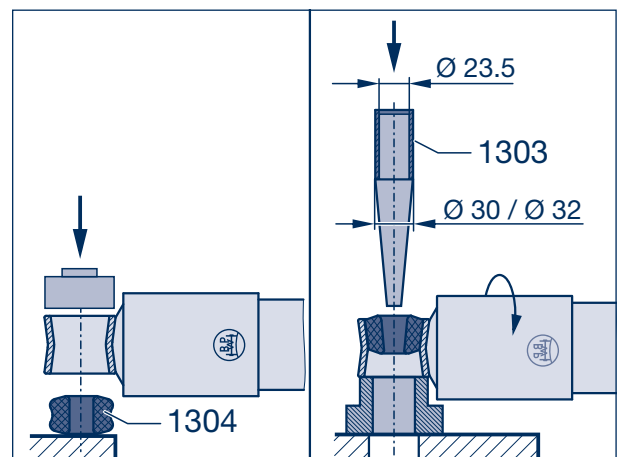

Figure 5



Repair note!
After replacing the rubber and steel bushes (1303, 1304), the protrusion on both sides of the shock absorber eye must be equal.

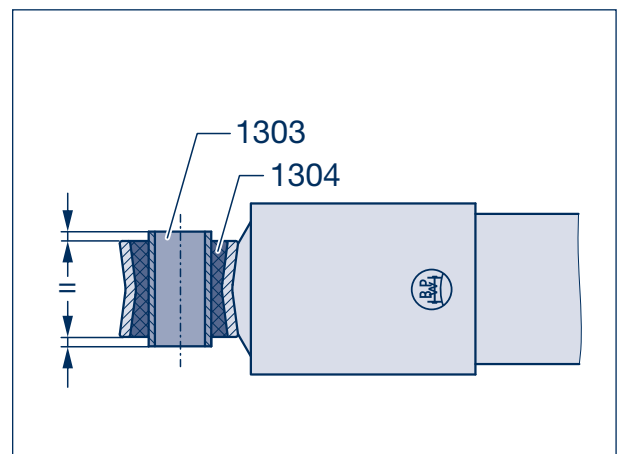

Figure 6

Disassembling and installing axle lift device 13

13.1 Two-side axle lift

Disassembly

- [1] Support axle to prevent accidents and deflate air suspension.
- [2] Remove the lock nut M 10 (1623 / SW 16) from the positioning pin (1621).
- [3] Install support (1610) with shaped plate (1613) and secure lifting cylinder (1660) against falling down, remove positioning pin.
- [4] Pull complete unit out of holder in air suspension hanger bracket and remove.

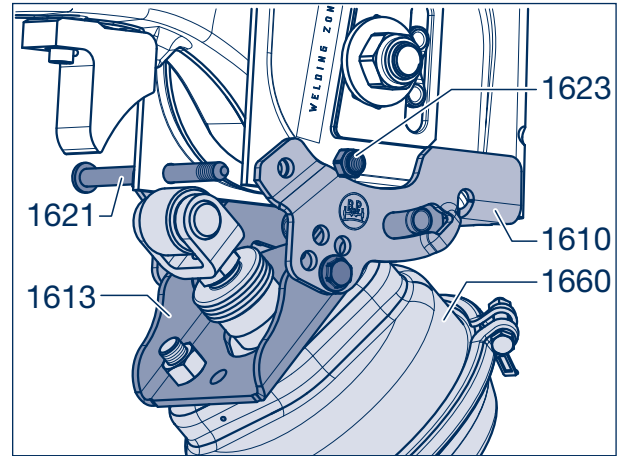

Figure 1

- [5] If necessary remove lock nuts (1636, SW 17) from locking screws (1635) and dismantle axle lift. Note position of locking screw.

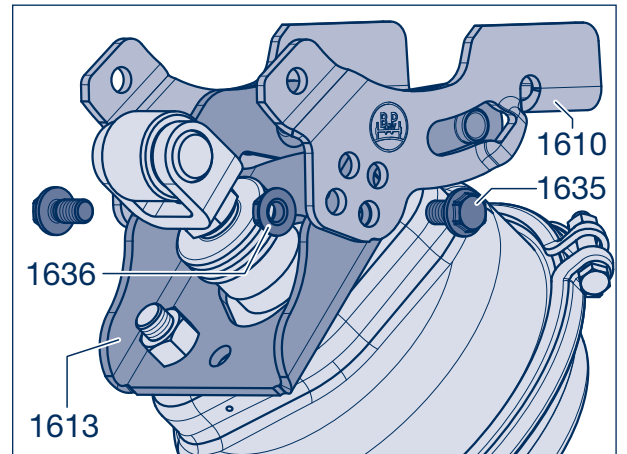

Figure 2

- [6] If necessary, remove lift cylinder (1660), by removing the two lock nuts (1663, SW 24) from the threaded bolts for the lift cylinder.

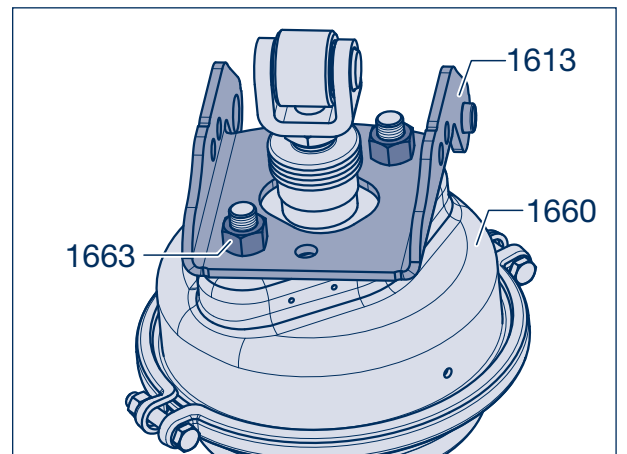

Figure 3

13 Disassembling and installing axle lift device

- [7] If necessary, remove cylinder head screw (1644, SW 8) with washer (1643) out of shaped part (1640) or trailing arm (1000).



Repair note!

If a TSB 3709 or TSB 4309 disc brake with spring brake cylinder is installed on the axle, it is necessary to remove it in order to remove the shaped part.

- [8] Tap or drill out upper dowel flange (1642) and drive dowel out through shaped part and trailing arm with drift punch.
- [9] Pull shaped part off trailing arm seat and remove.

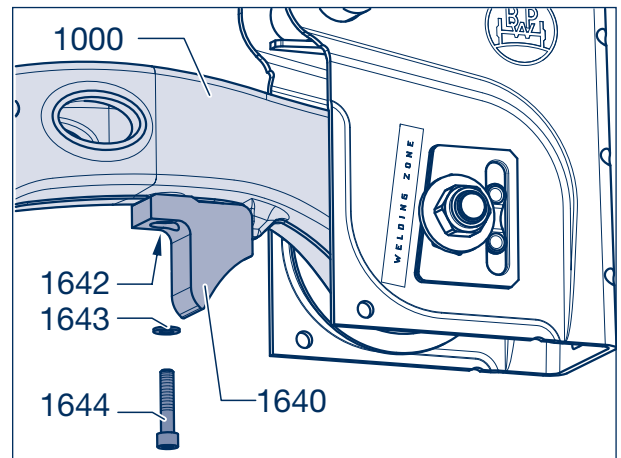

Figure 4

Installation



Note!

Clean all parts, check for wear and damage, replace, if necessary.

- [10] If removed, position shaped part (1640) on mount on trailing arm (arrow).
- [11] Install cylinder head screw (1644, SW 8) with washer (1643) into new dowel (1642).
- [12] Drive screwed joint into holes in shaped part (1640) and trailing arm (1000) with hammer.
- [13] Tighten cylinder head screw to the specified tightening torque of 50 Nm.
- [14] If removed, position shaped plate (1613) in adapters on two-side axle lift support (1610, arrow).
- [15] Bolt bracket and shaped plate to position noted in work step [5] using locking screws (1635) and lock nuts (1636, SW 17).
Tightening torque: 75 Nm

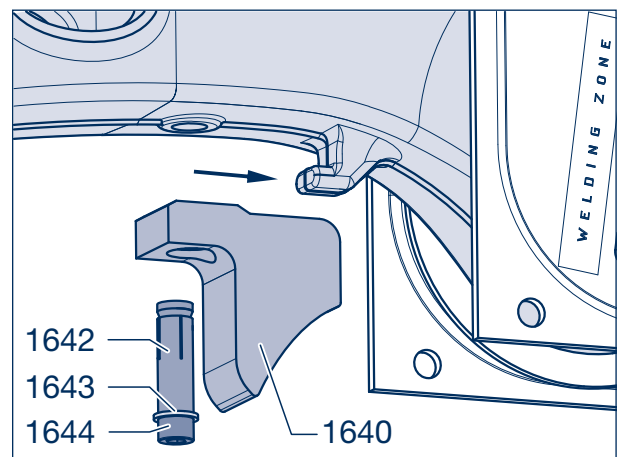

Figure 5

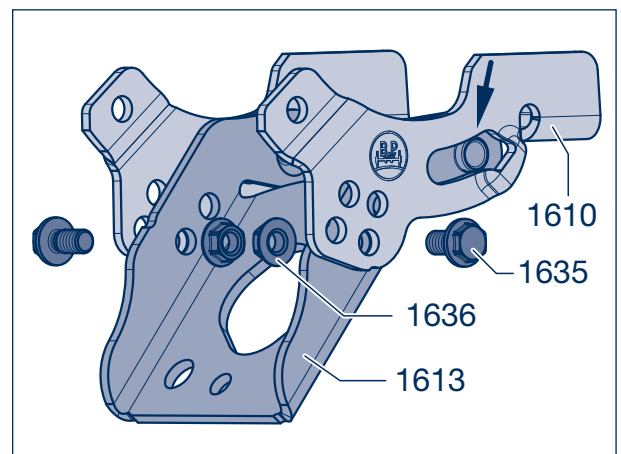

Figure 6

- [16] Install lift cylinder (1660) on bracket (1613) using lock nuts (1663, SW 24) and tighten to a tightening torque of $M = 190 \text{ Nm}$ (180 - 210 Nm).

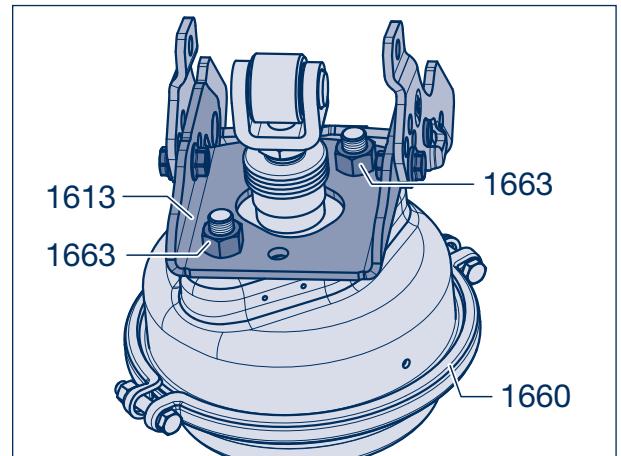

Figure 7

- [17] Position pre-assembled axle lift in recess (arrow) in air suspension hanger bracket.

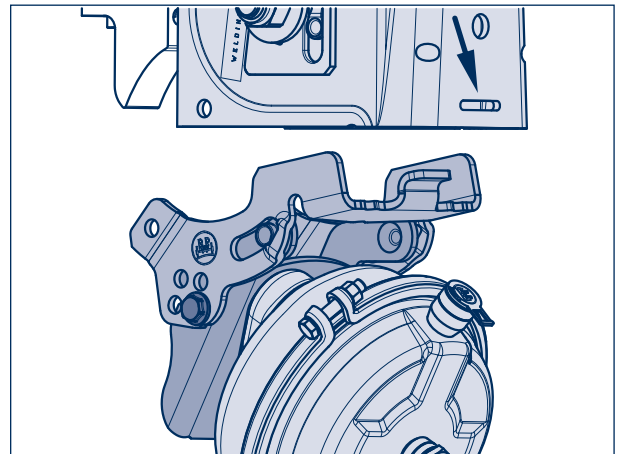

Figure 8

- [18] Raise axle lift. Fasten rear part of axle lift to air suspension hanger bracket with positioning pin (1621).
- [19] Attach the lock nut (1623 / SW 16) and tighten to a tightening torque of 38 Nm.



Repair note!
Ensure the correct fit of the locking washer in the groove!

- [20] Where applicable, reinstall disc brake cylinder, if removed previously.

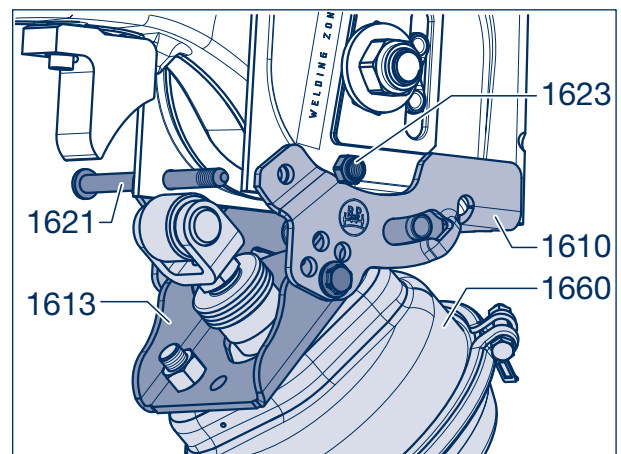

Figure 9

13 Disassembling and installing axle lift device

13.2 Sidewise mounted axle lift

Disassembly

- [1] Support axle to prevent accidents and deflate air suspension.
- [2] Unscrew lower locking screws or central screw (1224, SW 22) for lift bag (1200).

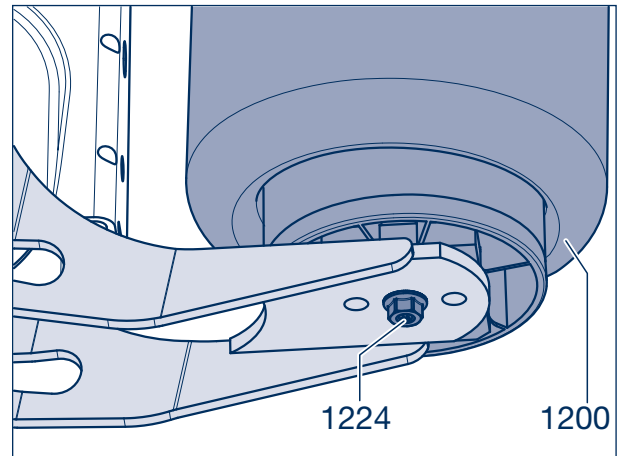

Figure 10

- [3] Screw lock nut (1168, SW 36) off the spring bolt (1156).
- [4] Remove washer (1165).
- [5] Secure lifting arm (1630) against falling down and drive out spring bolt.



Caution! INJURY HAZARD
Use hoist or have second person help remove lifting arm.

- [6] Remove lifting arm with bushes (1175, 1180), as well as adjusting plates (1161, 1560).

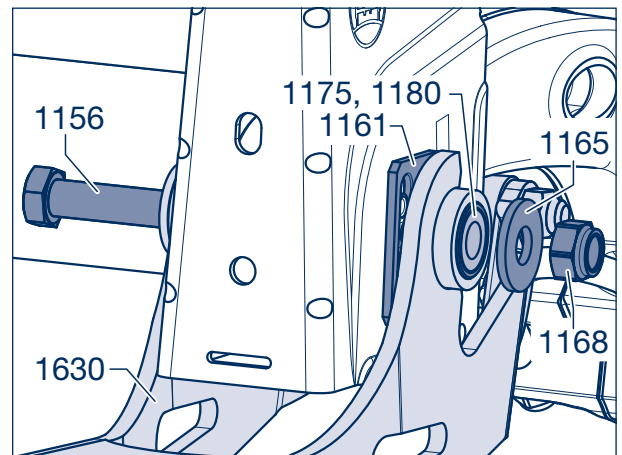

Figure 11

- [7] Remove lock nut (1640, SW 30) from hexagon screw (1637). Note position of screw.
- [8] Take out hexagon screw and remove bush (1635) with tube (1638).

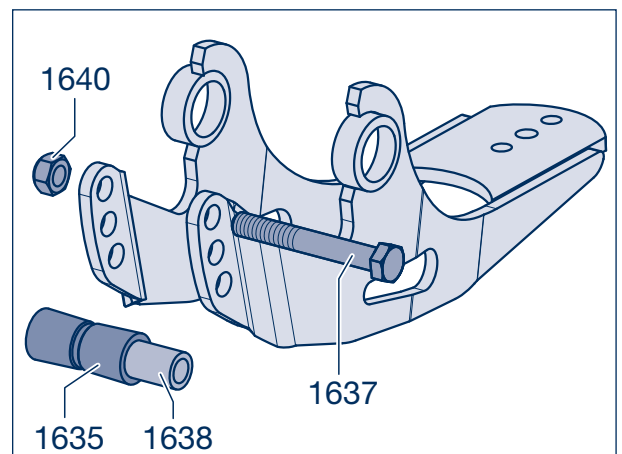

Figure 12

Installation



Note!
Clean all parts, check for wear and damage, replace, if necessary.

- [9] Position bush (1635) on tube (1638).
- [10] Use tube to install bush in lifting arm (1630) (position noted in work step [7]).
- [11] Install hexagon screw (1637).
- [12] Install lock nut (1640, SW 30) and tighten to a specified tightening torque of $M = 350 \text{ Nm}$ (325 - 385 Nm).

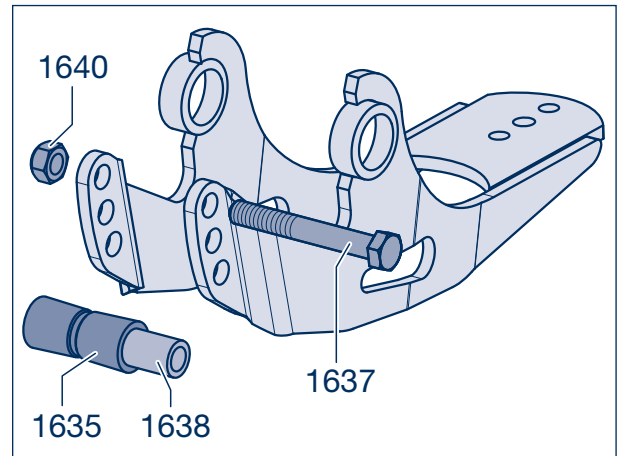

Figure 13

- [13] Position bush (1180) on graduated bush (1175).
- [14] Insert pre-assembled bushes into lifting arm (1630) from inside to outside.

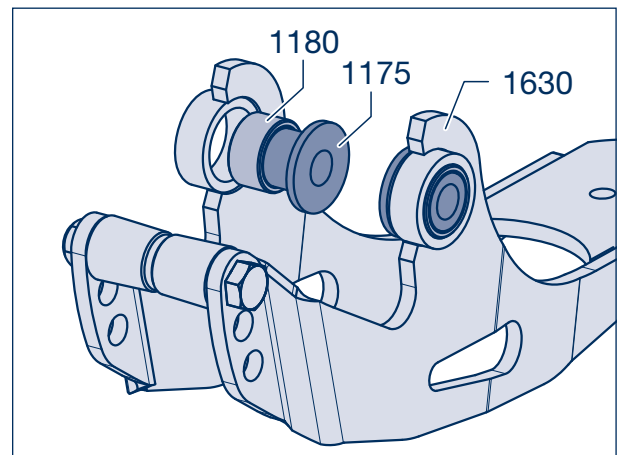

Figure 14

- [15] Attach adjusting plate with torsion protection (1560), position washer (1165) and insert new, lightly greased spring bolt (1156).

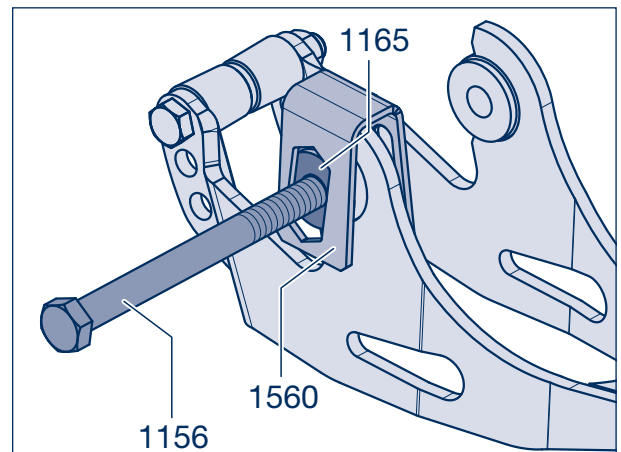

Figure 15

13 Disassembling and installing axle lift device

- [16] Raise pre-assembled axle lift device until bushes and bore holes for spring bolts (1156) are aligned.
- [17] Drive spring bolts in to end of air suspension hanger bracket. Ensure that wear washers (1525) are installed on bush (1005) in trailing arm (1000) (see Figure 14, Page 38).

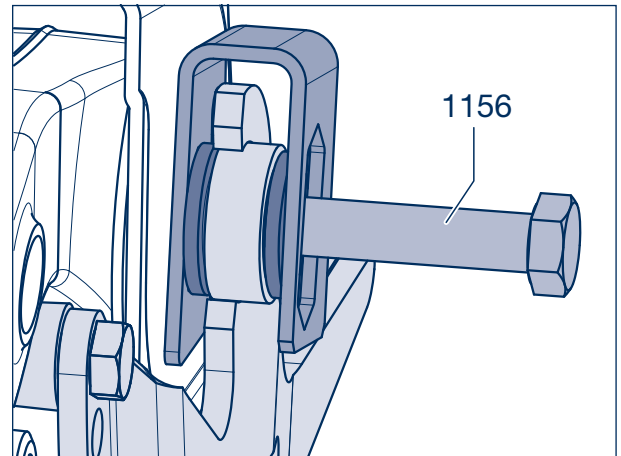

Figure 16

- [18] Install adjusting plate (1161) in correct position between air suspension hanger bracket (1511) and graduated bush (1175).
- [19] Completely insert spring bolt (1156).
- [20] Attach washer (1165), fit new lock nut (1168).
- [21] Insert spring bolt up to bumper.
- [22] Ensure that adjusting plate is correctly seated on torsion protection (arrows) on air suspension hanger bracket.
- [23] Tighten lock nut (1168) to a specified tightening torque of **650 Nm** (605 - 715 Nm).

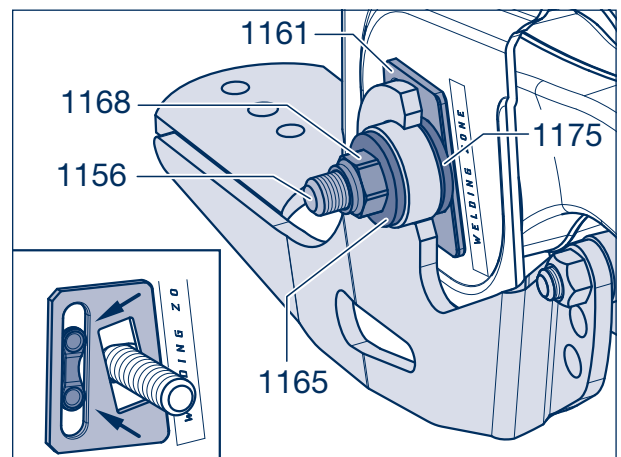

Figure 17

- [24] Fasten axle lift to lift air bags (1200) with locking screws or central screw (1224, SW 22).

Tightening torques:

Locking screws:	230 - 300 Nm
Central screw:	300 Nm

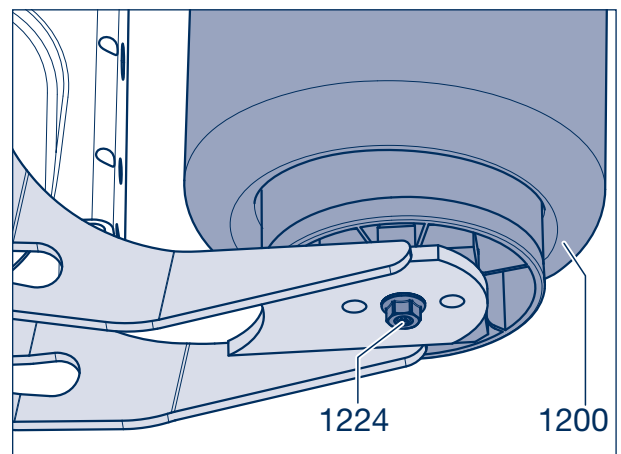

Figure 18

Air suspension valve 14

14.1 General

The air suspension valve controls the air bag pressure as a function of vehicle load and keeps the ride height at the same level no matter the load condition. It is attached to the chassis frame by screws and connected to the axle by a steering device. The steering device is located in the middle of the axle, on tri-axle suspensions at the centre axle, on two-axle suspensions on the rear axle. In special cases (e.g. axle lift device, large vehicle slope) the air suspension valve may also be connected to the front or rear axle. In exceptional cases, two air suspension valves may also be fitted.

14.2 Replacing

- [1] Deflate air suspension kit.
- [2] Unscrew union nuts of the compressed air lines from the connections at the air suspension valve.
- [3] Unscrew nut from the steering device at the axle.



Repair note!

Do not fit and secure nut (2) complete with spring washer (3) until after having adjusted the air suspension valve.

- [4] Undo fixing screws of the air suspension. Remove air suspension valve.
- [5] The valve is refitted on in the reverse order. Following this, check compressed air system for leaks.

14.3 Adjustments



Note!

The ride height is adjusted by matching the steering rod in the rubber joints and then fixing this position with the lock nuts (1).

The adjustment must be made on flat ground. If only one air suspension valve is fitted, the adjustment can be performed when the vehicle is laden or unladen. If two air suspension valves are fitted, the adjustment must be made when the vehicle is unladen.

- [1] Fill up compressed air reservoir. Unscrew nut (2) complete with spring washer (3).
- [2] To check operation, move valve lever down slightly. This must cause air to flow through the vent cap to atmosphere. If, however, this causes air to flow into the air bags, the valve shaft must be turned through 180 degrees. The valve lever must be switched over for this purpose.

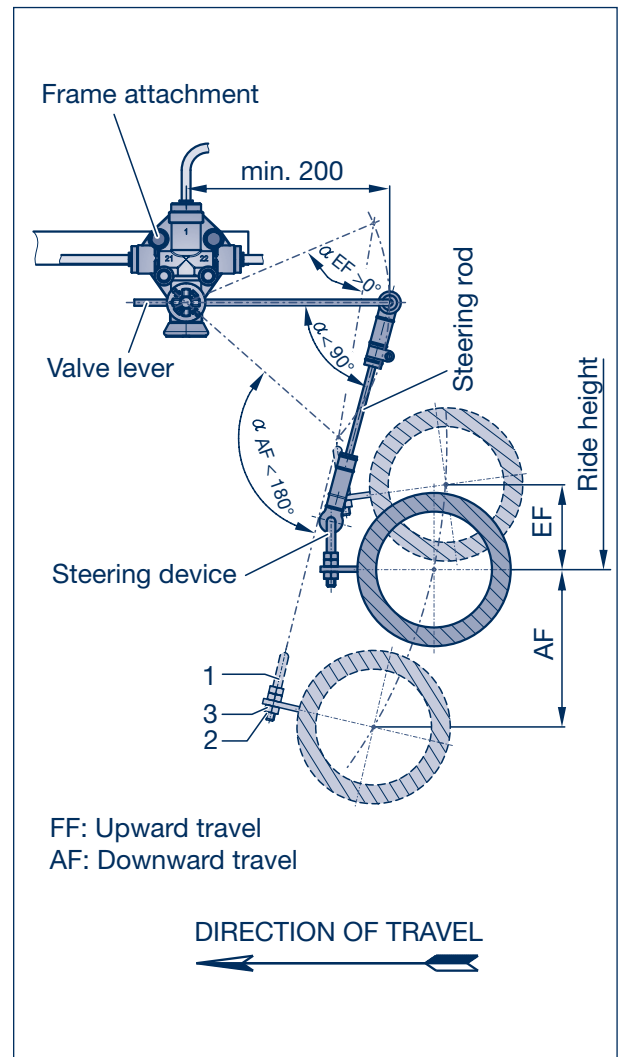

Figure 1

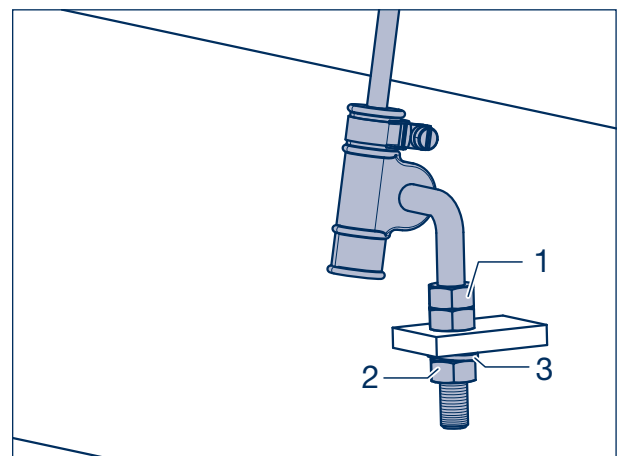

Figure 2

14 Air suspension valve

- [3] Check the length of the valve lever (4); it must be at least 200 mm; if necessary, alter accordingly after slackening the clamping screw (arrow) and re-tighten clamping screw.



Repair note!

The angles stated (Figure 1) must neither be underrun nor overrun to prevent the valve linkage going over centre.

- [4] Press valve lever down and hold in this position until the vehicle has fully lowered.
- [5] Slowly push valve lever up and hold until a single-axle vehicle has been raised by at least 60 mm, two- and tri-axle suspensions by at least 70 mm and vehicles with axle lift device by at least 100 mm.
- [6] After these setting heights have been reached, the air suspension valve lever must be moved into the horizontal position (Figure 1).



Note:

This adjustment achieves the minimum ride height.

- [7] Insert steering device (5) into the fastening lug on the axle beam. Screw on nut (2) with spring washer (3).
- [8] Connect valve lever and steering device to one another via the steering rod (6). After assembly, the valve lever must be in the horizontal position. If necessary, adjust the double nut (1) and tighten the nut (3), fasten the steering rod by tightening the screws at the clamps.

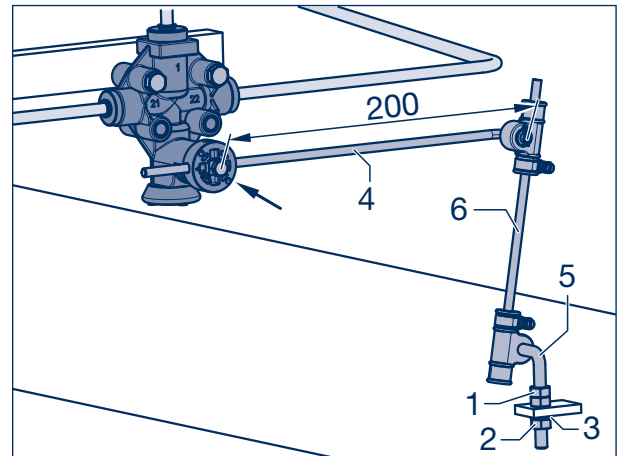

Figure 3

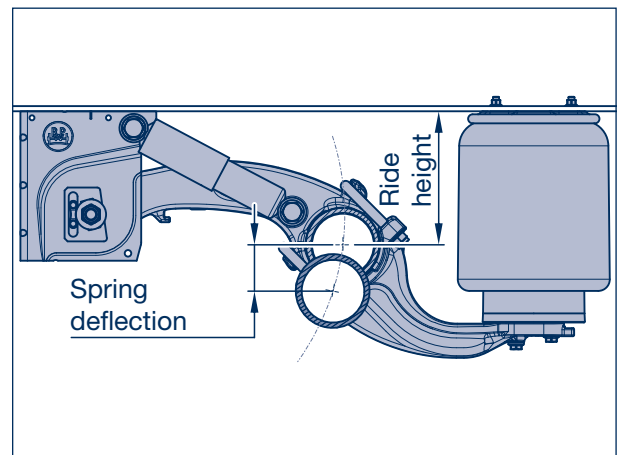

Figure 4

Spring deflection

Single axes:	60 mm
Two and tri-axle suspensions:	70 mm
with axle lift device:	100 mm

Axle alignment check 15

Repair note:

In the case of suspensions with a self-steered axle, engage the steering lock. Zero position of the steering pivot is absolutely essential.

Note:

The triangle in the BPW logo is concentric with the axle.

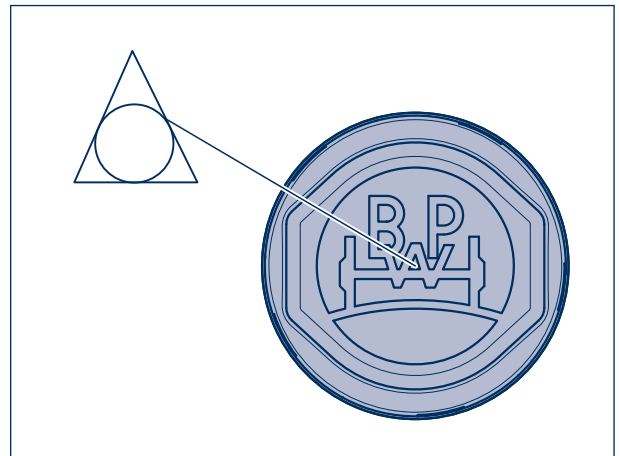

Figure 1

15.1 Conventional axle alignment check on the vehicle

- [1] Determine the diagonal dimensions **A - B** and **A - C** for the mid-axle (reference axle) by means of comparative measurements (± 2 mm tolerance).

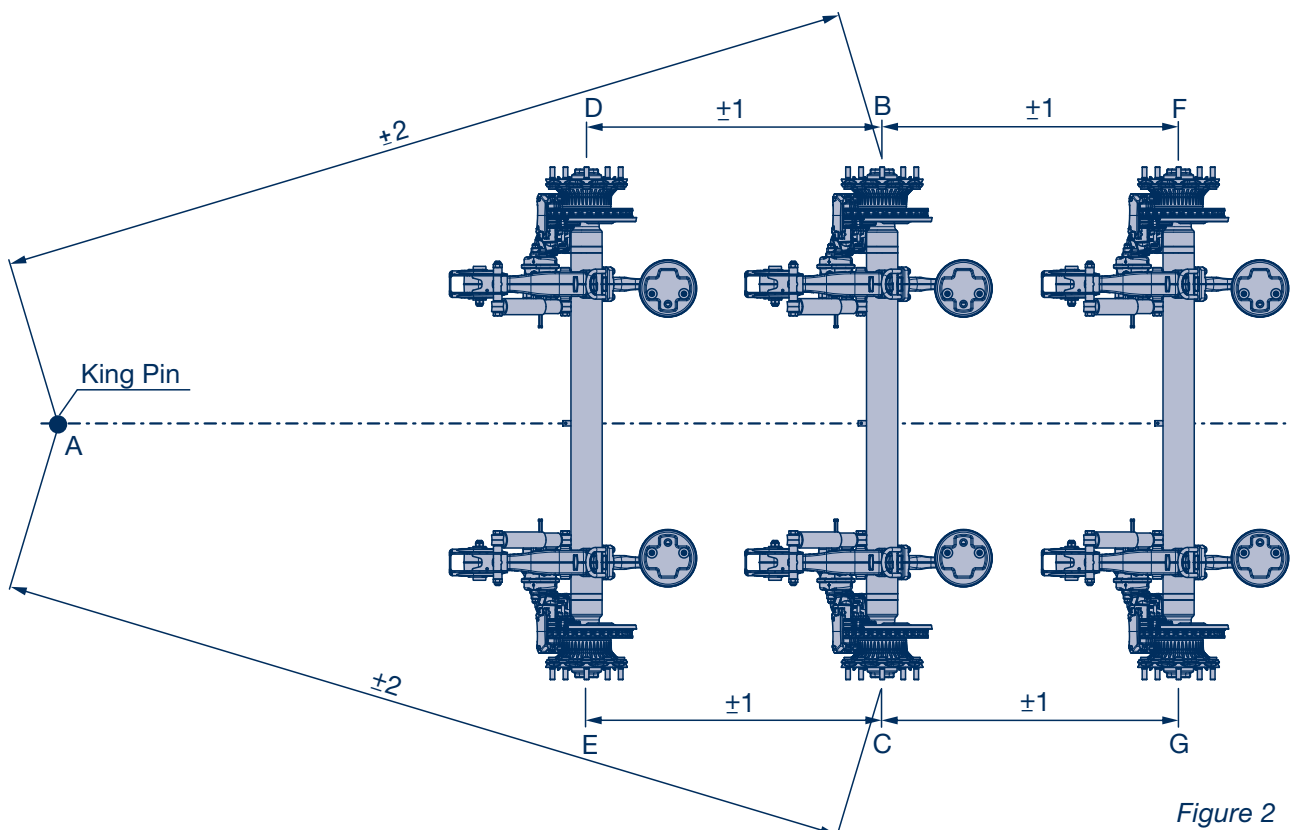

Figure 2

15 Axle alignment check



Note:

Care must be taken to ensure that the axle is aligned horizontally (at ride height) with the base in order to obtain a correct measurement.

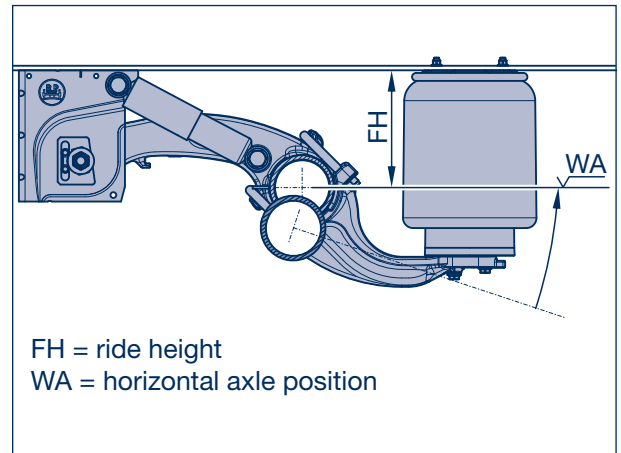

Figure 3



Note:

Measurement is generally carried out by means of the hub cap centre point (Figure 1, page 57). It can also be carried out using suitable distancing devices or screwed-on calibration tubes.

The triangle in the BPW logo is in the centre and can be used for holding a measuring tool.

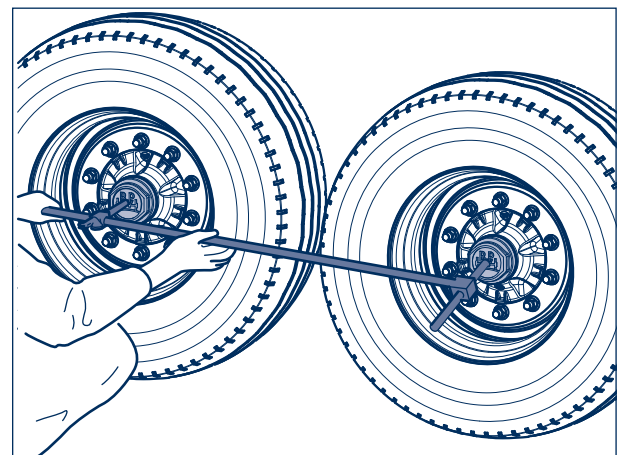

Figure 4

[2] Check wheel base measurements **B - D** and **C - E** for the front axle and **B - F** and **C - G** for the rear axle.

[3] If the tolerance is exceeded, the axle must be aligned under the vehicle. The spring U-bolts must not be loosened. Raise and support the vehicle frame at normal height.

[4] Deflate air bags (1200).

[5] Loosen lock nut (1168, SW 36) on spring bolt (1154) slightly.

[6] Move adjusting plates (1161) on both sides up or down, depending on required adjustment direction, by tapping lightly with hammer.



Repair note:

Make sure the inner and outer adjusting plates on each hanger bracket are adjusted symmetrically!

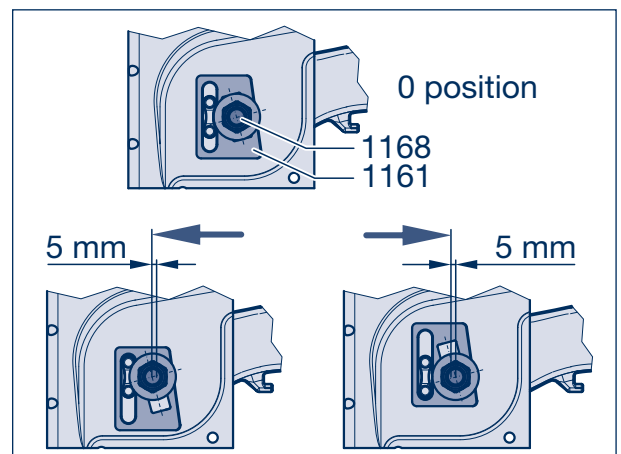

Figure 5

- [7] After correction, screw in lock nut (1168) on spring bolt (1154) and tighten to specified tightening torque of $M = 650 \text{ Nm}$ (605 - 715 Nm).

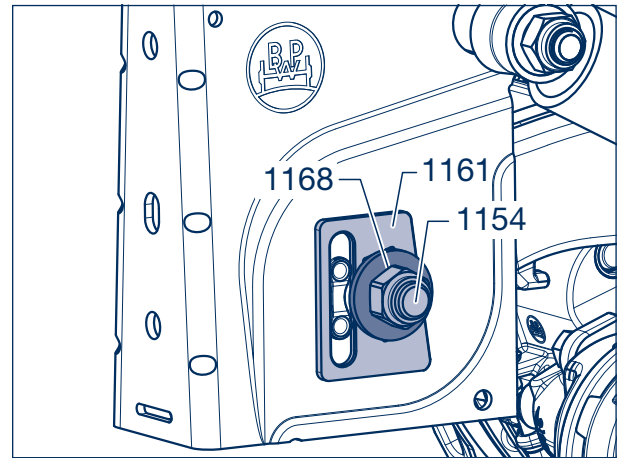

Figure 6



Repair note:

Pay particular attention to the correct position of the adjusting plate (1161) on the torsion protection (arrows) of the air suspension hanger brackets!

The square on the spring bolt head (torsion protection) must sit in the slot of the adjusting plate.

- [8] Inflate the air bags (1200) and remove supports from underneath the vehicle.

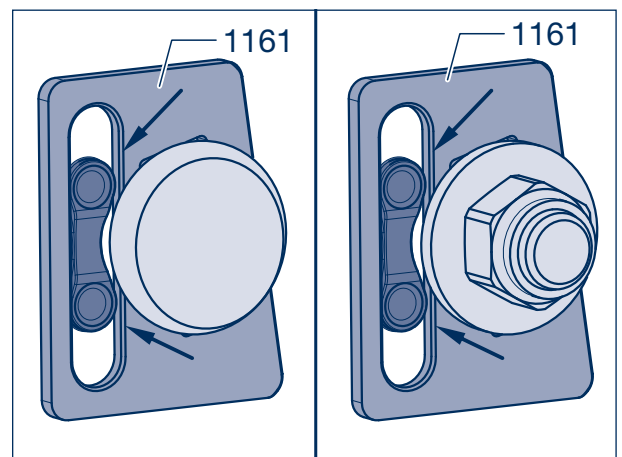

Figure 7

15 Axle alignment check

15.2 Axle alignment check with laser measuring devices

- [1] Set up the laser in accordance with the manufacturer's instructions (see Figure 9). Make sure the axle is positioned **horizontally** to prevent camber values corrupting the measuring results. An unladen vehicle is assumed.
- [2] Take the measurement on both sides, determining the toe values on the right and left wheel sides axle by axle.

Calculating the toe values:

$$\text{Axle track (mm/m)} = \frac{(\text{AR} - \text{BR}) + (\text{AL} - \text{BL})}{L}$$

Positive value = toe-in

Negative value = toe-out

Target values (total axle track):

Rigid axle

=> -1 + 5 mm/m

Rear self-steering axle

=> 0 + 4 mm/m (drum brake)

=> -5 - 1 mm/m (disc brake)



Note:

Instead of measuring all three axles using the laser method, it is also possible to only track the mid-axle using the laser method.

The front and rear axle are positioned relatively to the mid-axle using suitable axle centre distance devices (like during conventional tracking).

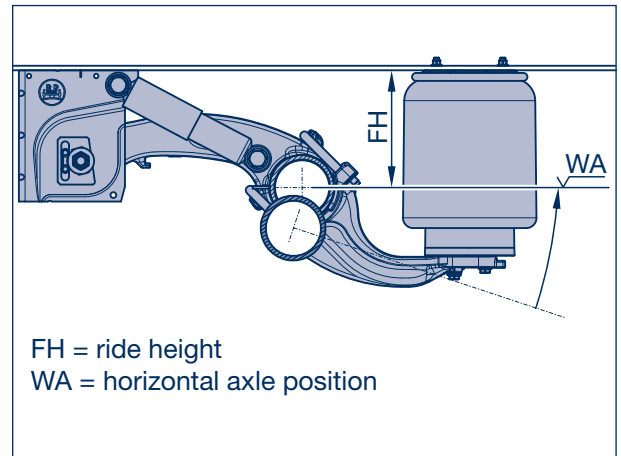

Figure 8

- [3] Correct track if out of tolerance (see chapter 15.1).

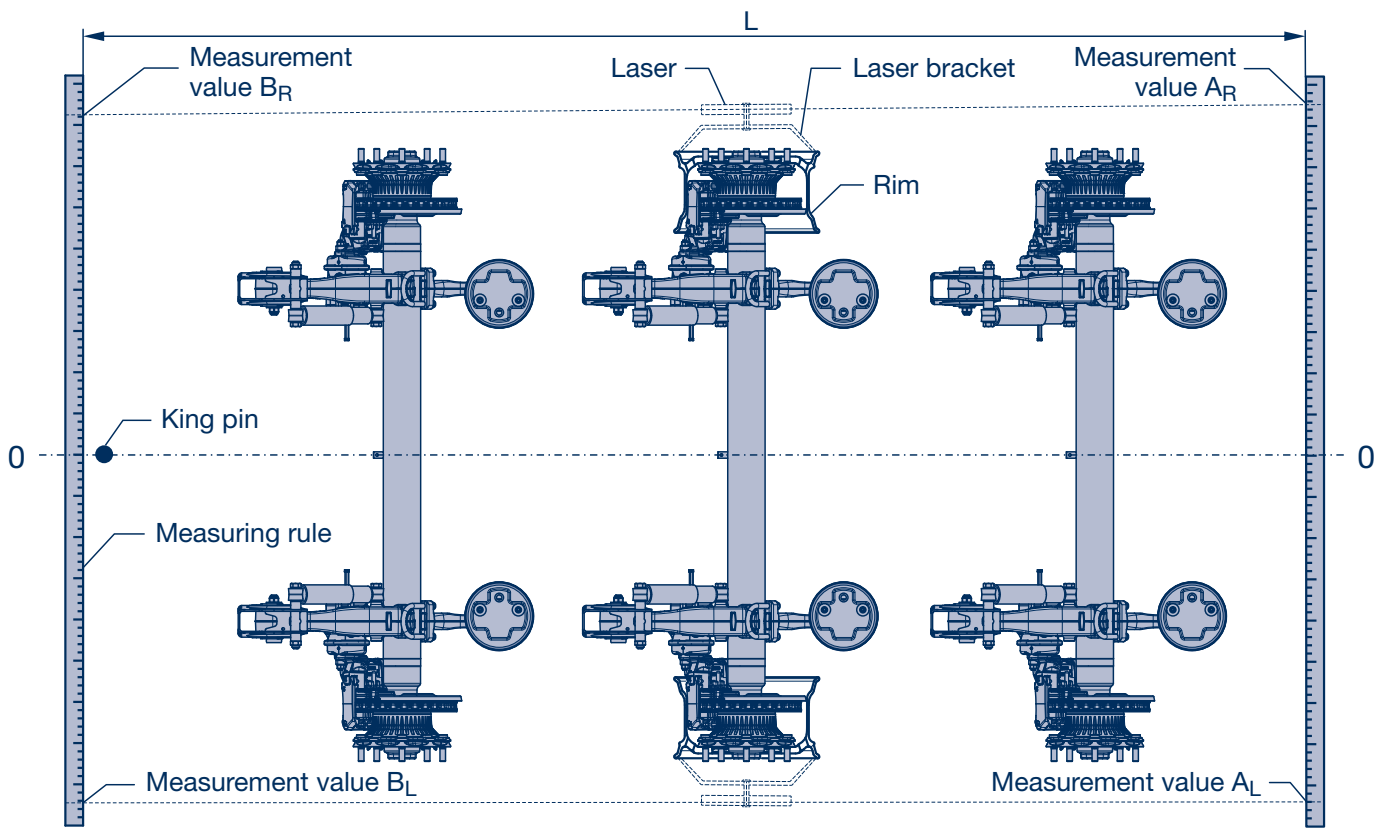

Figure 9

16 Notes

BPW is a globally leading manufacturer of intelligent running gear systems for trailers and semi-trailers. As an international mobility and system partner, we offer a wide range of solutions for the transport industry from a single source, from axle to suspension and brake to user-friendly telematics applications.

We thereby ensure outstanding transparency in loading and transport processes and facilitate efficient fleet management. Today, the well-established brand represents an international corporation with a wide product and service portfolio for the commercial vehicle industry. Offering running gear systems, telematics, lighting systems, composite solutions and trailer superstructures, BPW is the right system partner for automotive manufacturers.

BPW, the owner-operated company, consistently pursues one target: To always give you exactly the solution which will pay off. To this end, we focus our attention on uncompromising quality for high reliability and service life, weight and time-saving concepts for low operating and maintenance costs as well as personal customer service and a close-knit service network for quick and direct support. You can be sure that with your international mobility partner BPW, you always use the most efficient method.

Your partner on the path to economic viability



BPW Bergische Achsen Kommanditgesellschaft

Postbox 12 80 · 51656 Wiehl, Germany · Phone +49 (0) 2262 78-0

info@bpw.de · www.bpw.de