

VB

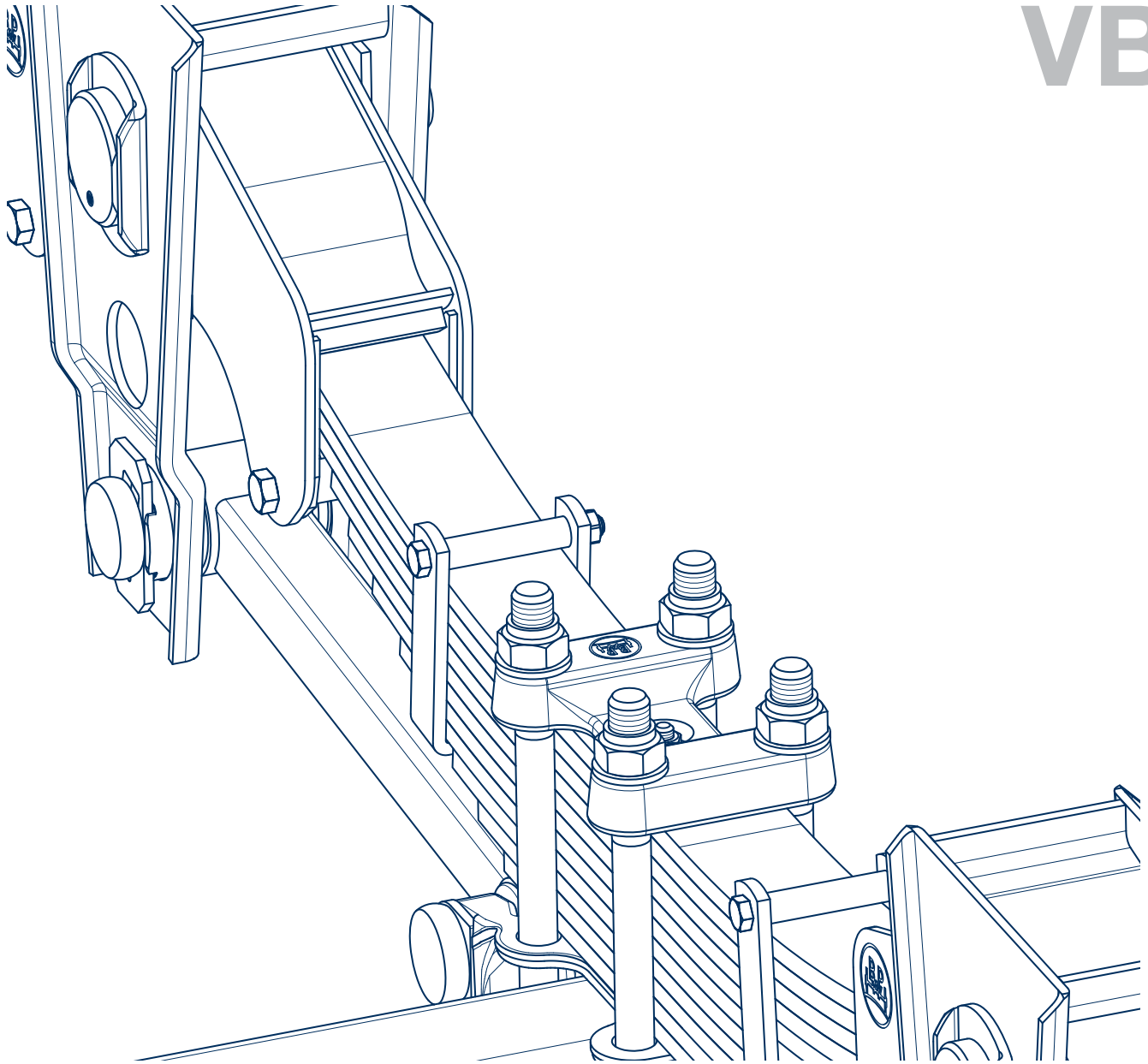

Workshop manual

BPW leaf spring suspensions, VB



Valid: 01.07.2015

4th edition

Subject to change without notice.

Current versions and additional information can be found online at www.bpw.de.

Contents

◎ 1. Product identification	Page 4
1.1 Explanation of BPW axle type codes (extract)	Page 4
1.2 Explanation of BPW code numbers (extract)	Page 5
◎ 2. Special tools	Page 6
◎ 3. Exploded view / name	Page 9
◎ 4. Tightening torques	Page 13
◎ 5. Safety regulations, safety information	Page 14
5.1 Safety regulations	Page 14
5.2 Safety information	Page 15
◎ 6. Care and maintenance	Page 16
◎ 7. Removing and installing axle with leaf springs	Page 22
7.1 Removing	Page 22
7.2 Replacing the bushes in the connecting rods	Page 24
7.3 Installing	Page 27
◎ 8. Removing and installing U-stabiliser	Page 30
◎ 9. Removing and installing leaf springs	Page 33
◎ 10. Removing and installing equalising beam	Page 35
10.1 Removing equalising beam	Page 35
10.2 Replacing bronze bushes	Page 37
10.3 Replace the rubber-steel bush	Page 38
10.4 Install equaliser beam	Page 39
◎ 11. Axle alignment check	Page 44
◎ 12. Axle alignment check with laser measuring devices	Page 48

- Refer to appropriate workshop manuals for axle repairs

1 Product identification

1.1 Explanation of BPW axle type codes (extract)

Example:

HSF	VB	U	LL	2/	12010	/12°	M	ECO Plus 2	ECO Cargo
HSF	Example for axle type								
	VB	Mechanical suspension without braking load compensation, leaf springs above the axle							
	VBN	Mechanical suspension without braking load compensation, leaf springs above the axle, low design, only with VB ECO Cargo							
	VBT	Mechanical suspension without braking load compensation, leaf springs below the axle							
	U	With U-stabiliser							
		L	With steering axle, series L, steering angle max. 40°						
		LL	With self-steering axle, series LL, steering angle max. 27°						
		-	Single axle						
		2/	Tandem axle suspension						
		3/	Tri-axle suspension						
			6006 to 20010	Axle load (kg) + quantity of wheel studs per hub					
				/12° to /40°	Steering angle of steering axle				
					B	Reinforced			
					BE	Reinforced, equaliser bearing with bronze bushes			
					E	Equaliser bearing with bronze bushes			
					HD	Heavy duty version			
					HDE	Heavy duty version equaliser bearing with bronze bushes			
					K	Weight-optimized version			
					KE	Equaliser bearing with bronze bushes			
					KN	Low construction height			
					L	Reinforced			
					LE	Reinforced, equaliser bearing with bronze bushes			
					M	Reinforced			
					ME	Reinforced, equaliser bearing with bronze bushes			
					MN	Reinforced, low construction height			
					MNE	Reinforced, low construction height, equaliser bearing with bronze bushes			
					ECO Plus 2	BPW trailer axle with ECO Plus 2 Unit			
					ECO ^{Plus}	BPW trailer axle with ECO ^{Plus} Unit			
					ECO MAXX	Weight-optimized BPW trailer axle with ECO Unit			
					MAXX	Weight-optimized BPW trailer axle with conventional hub bearing system			
					ECO	BPW trailer axle with ECO Unit			
					ECO Cargo	New running gear system as from 2013			

1.2 Explanation of BPW code numbers (extract)

Example:

32.	58.	744.	018	
				1. + 2. digit
21.				Single axle with suspension parts
28.				
30.				
38.				
22.				Tandem axle suspension
23.				Tri-axle suspension / Four axle suspension / Five axle suspension
32.				Tandem axle suspension / Tri-axle suspension / Four axle suspension / Five axle suspension
39.				Tri-axle suspension / Four axle suspension / Five axle suspension
				3. + 4. digit
		Axle load	Roller bearings	Hub bearing system
06.		6500 kg	33116 / 32310	Conventional hub bearing system
08.		8000 - 9000 kg	33116 / 32310	
09.		8000 - 9000 kg	33116 / 32310	
10.		10000 - 12000 kg	33118 / 33213	
14.		13000 - 14000 kg	32219 / 33215	
16.		16000 - 18000 kg	32222 / 32314	
20.		20000 kg	32224 / 32316	
36.		6500 kg	33116 / 32310	
38.		8000 - 9000 kg	33116 / 32310	
40.		10000 - 12000 kg	33118 / 33213	
44.		13000 - 14000 kg	32219 / 33215	
48.		8000 - 9000 kg	33118 / 33213	ECO ^{Plus} Unit
49.		8000 - 9000 kg	33118 / 33213	
50.		10000 - 12000 kg	33118 / 33213	
51.		10000 - 12000 kg	33118 / 33213	
56.		6500 - 7000 kg	33118 / 33213	ECO Plus 2 Unit
58.		8000 - 9000 kg	33118 / 33213	
59.		8000 - 9000 kg	33118 / 33213	
65.		6400 kg	33215 / 32310	Conventional hub bearing system
				5. - 7. digit
501.				Designation of wheel brake in the case of ref. number 20. - 39... For explanation of the code number, see the respective rigid axle.
to 839.				
				8. - 10. digit
	000			Consecutive number 000 - 999
	to 999			

2 Special tools

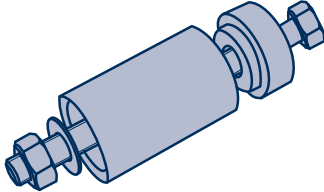
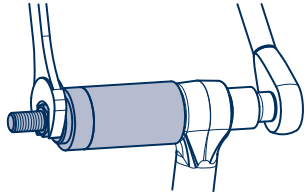
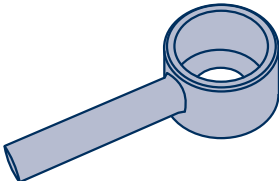
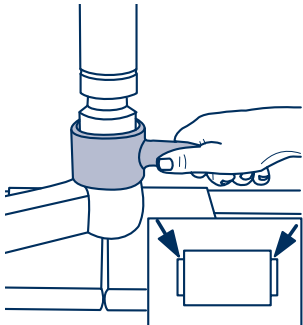
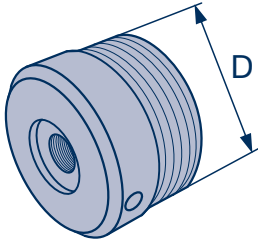
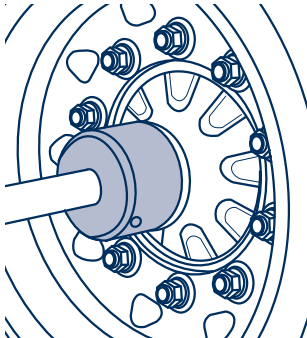
Number	Description	Illustration of tool	Tool in operation
1	Installation and removal tool for rubber-steel bushes Ø 50 - 60 mm BPW code number: 14.825.11744		
2	Press tool - for bush in U-stabiliser BPW code number: 15.002.19433 Ø 52.6 - for bush in connecting rod assembly BPW code number: 15.003.19433 Ø 60 15.009.19433 Ø 60 ECO Cargo 15.004.19433 Ø 66 - for bush in equalising beam BPW code number: 15.006.19433 Ø 100 15.007.19433 Ø 107		
3	Threaded adapter for alignment of axles and suspensions BPW code number: Conventional hub bearing 15.013.01609 M 115 x 2 6.5 - 9 t 15.014.01609 M 125 x 2 10 - 12 t 15.012.01609 M 135 x 3 13 - 14 t 16.008.01609 M 155 x 3 16 - 18 t ECO Unit 15.020.01609 M 125 x 2 6.5 - 9 t 15.021.01609 M 135 x 2 10 - 12 t (old) 15.023.01609 M 136 x 2.5 10 t (new) ECO Plus Unit 15.023.01609 M 136 x 2.5 8 - 12 t		

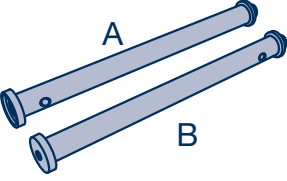
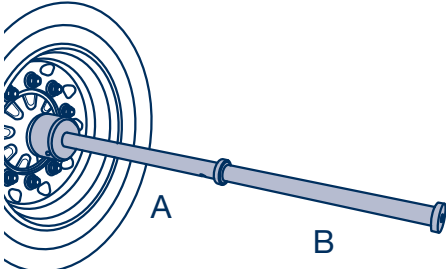
Number	Description	Illustration of tool	Tool in operation
4	Aligning tubes for alignment of axles and suspensions BPW code number: 15.001.01609 A 15.005.01609 B		



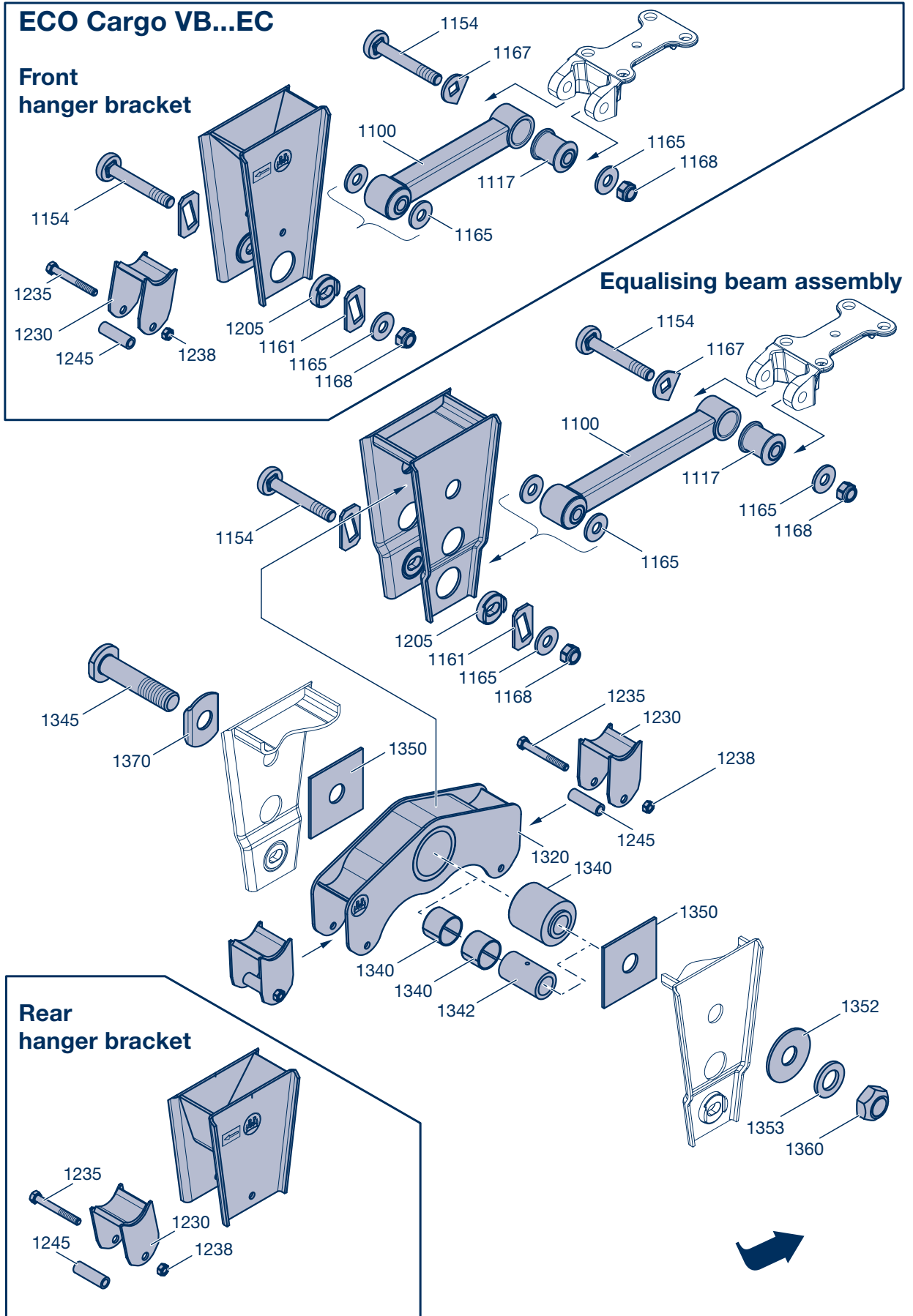

3 Exploded view

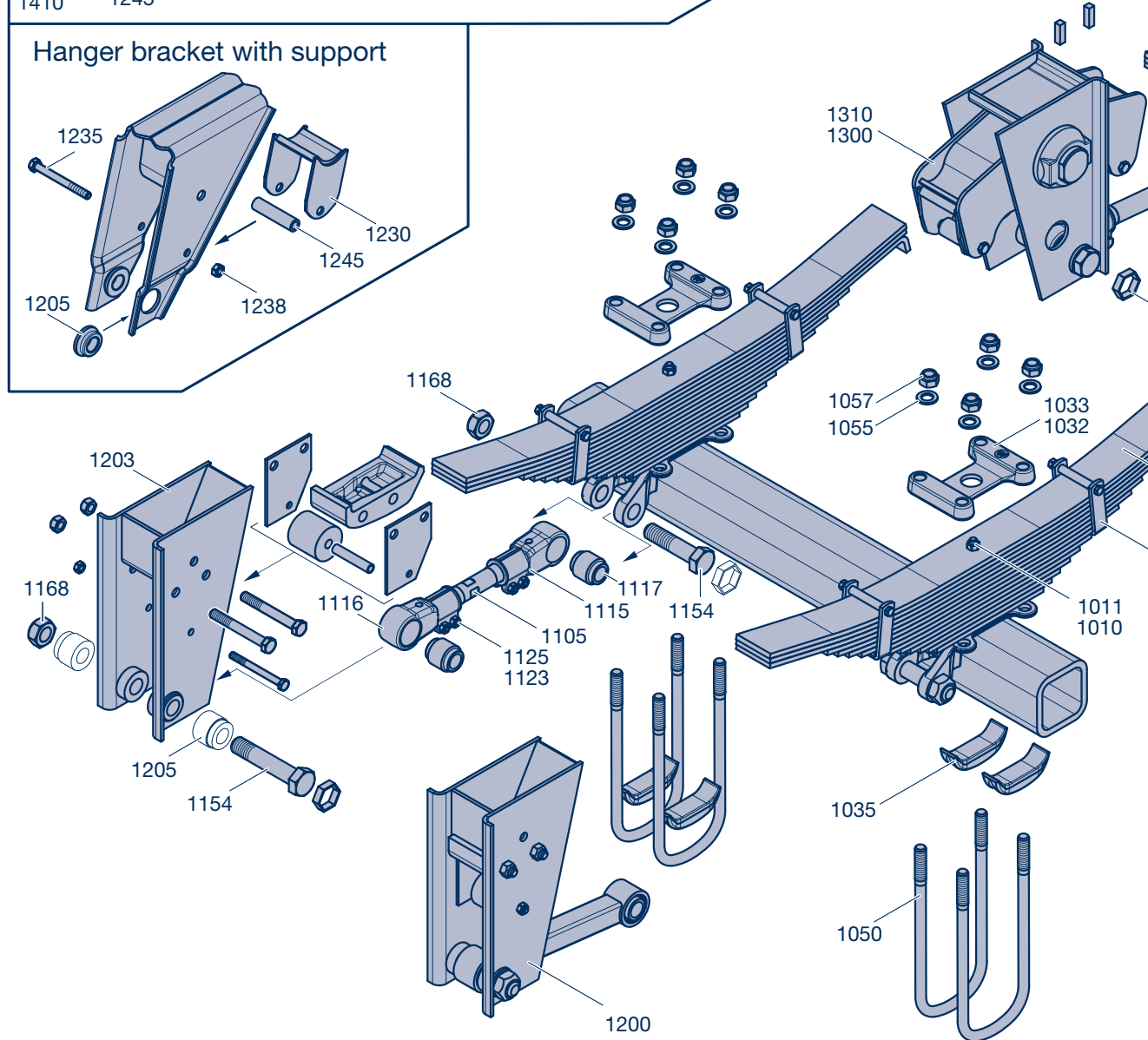
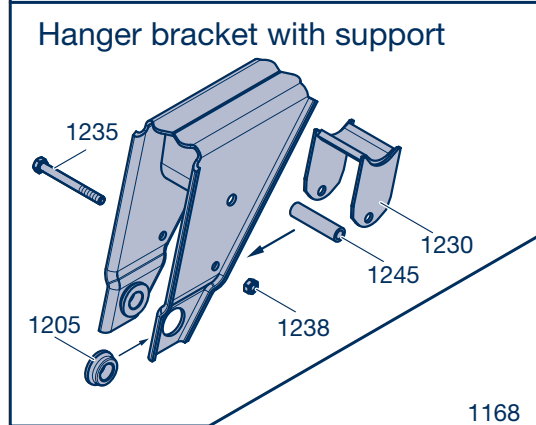
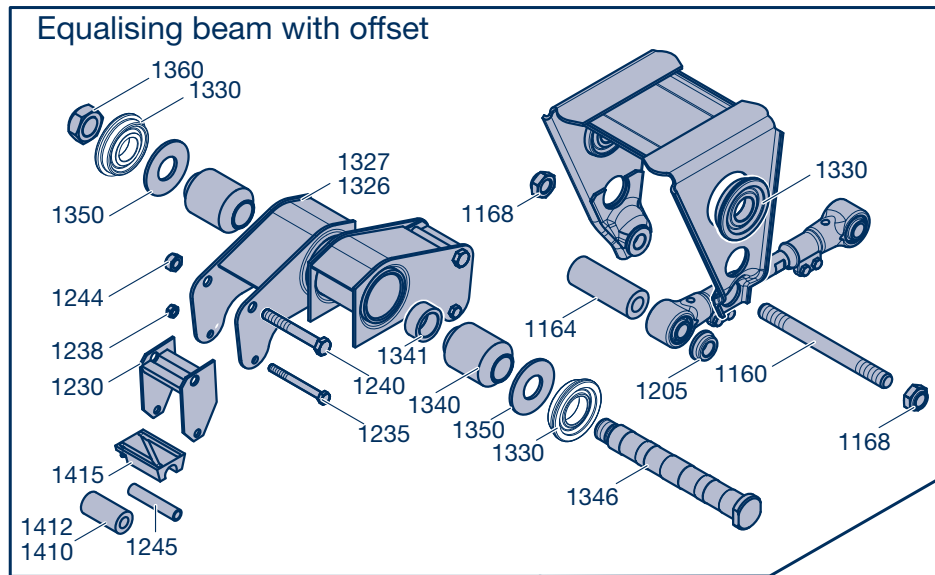

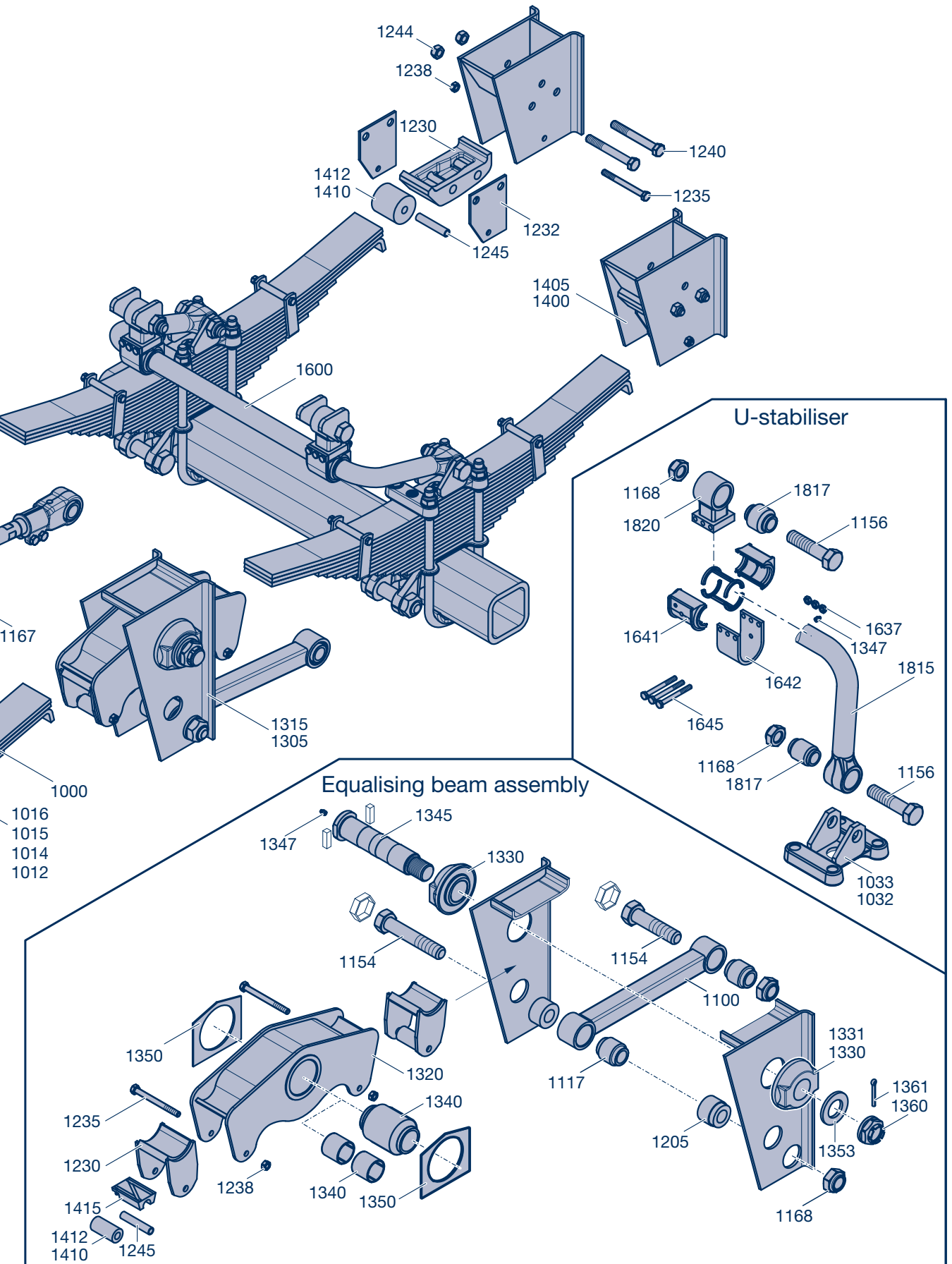

Name

Pos.	Name	Pos.	Name	Pos.	Name
1000	Leaf spring	1300	Equalising beam assembly	1400	Rear hanger bracket
1010	Spring screw	1305	Equalising beam assembly	1405	Rear hanger bracket
1011	Hexagon nut	1310	Equalising beam assembly	1230	Block
1012	Spring clamp	1315	Equalising beam assembly	1230	Support (slider)
1014	Hexagon screw	1100	Connecting rod, rigid	1232	Plate
1015	Hexagon nut	1105	Connecting rod, adjustable	1235	Hexagon screw
1016	Tube	1115	Tensioner head, left threaded	1238	Lock nut
1028	Support VB	1116	Tensioner head, right threaded	1240	Hexagon screw
1032	Spring plate	1117	Bush	1244	Lock nut
1033	Spring plate	1123	Hexagon screw	1245	Tube
1035	Segment	1125	Lock nut	1410	Rubber bush (silent block bush)
1050	Spring U-bolt	1154	Hexagon screw	1412	Bush
1055	Disc	1155	Hexagon screw	1415	Slider
1057	Lock nut	1160	Screw		
1167	Shaped part	1161	Plate (adjusting plate version VB...EC)	1600	U-stabiliser
1200	Front hanger bracket	1164	Tube	1032	Spring plate
1203	Front hanger bracket	1165	Disc (execution VB...EC)	1033	Spring plate
1100	Connecting rod, rigid	1167	Anti-rotation device for bolts (execution VB...EC)	1156	Hexagon screw
1105	Connecting rod, adjustable	1168	Lock nut	1168	Lock nut
1115	Tensioner head, left threaded	1205	Bush	1347	Grease nipple
1116	Tensioner head, right threaded	1230	Support (slider)	1637	Lock nut
1117	Bush	1235	Hexagon screw	1641	Bush
1123	Hexagon screw	1238	Lock nut	1642	Shaped plate
1125	Lock nut	1240	Hexagon screw	1645	Hexagon screw
1154	Hexagon screw	1244	Lock nut	1815	U-bolt
1155	Hexagon screw	1245	Tube	1817	Bush
1161	Plate (adjusting plate execution VB...EC)	1320	Equalising beam	1820	Support
1165	Disc (execution VB...EC)	1326	Equalising beam		
1167	Anti-rotation device for bolts (execution VB...EC)	1327	Equalising beam		
1168	Lock nut	1330	Bush		
1205	Bush	1331	Bush		
1230	Support (slider)	1340	Bush		
1232	Plate	1341	Ring		
1235	Hexagon screw	1342	Sleeve (execution VB...EC)		
1238	Lock nut	1345	Thread bolt		
1240	Hexagon screw	1346	Thread bolt		
1244	Lock nut	1347	Grease nipple		
1245	Tube	1350	Ring		
1410	Bush (Silent block bush)	1350	Plate (wearing plate)		
1412	Bush	1352	Disc (execution VB...EC)		
1415	Slider	1353	Disc		
		1360	Lock nut		
		1360	Castle nut		
		1361	Split pin		
		1370	Ring / Shaped plate (version VB...EC)		
		1410	Rubber bush (silent block bush)		
		1412	Bush		
		1415	Slider		

Tightening torques **4**

Item	Description	Thread / Spanner size	Tightening torque
1360	Nuts on the equaliser arm bearings - up to an axle load of 12 tonnes (from 08/2013) - up to an axle load of 12 tonnes (up to 07/2013) - from an axle load of 13 tonnes - series HD / HDE	M 42 x 3 / SW 65 M 42 x 3 / SW 65 M 42 x 3 / SW 65 M 48 x 3 / SW 65	M = 1300 Nm M = 1100 Nm M = 1700 Nm M = 1200 - 1300 Nm
1168	Lock nuts of the axle / connecting rods	M 36 / SW 55 M 30 / SW 46 M 24 x 2 / SW 36	M = 1425 Nm M = 725 Nm M = 650 Nm
1168	Locking nut of securing bolt for stabiliser	M 30 / SW 46	M = 700 - 750 Nm
1057	Locking nuts of U-bolt	M 24 / SW 36	M = 600 - 650 Nm
1244 1238	Locking nuts of securing bolts of the spring slide	M 20 / SW 30 M 14 / SW 22	M = 320 Nm M = 140 Nm
1011	Hexagon nut of centre bolt for leaf springs	M 16 / SW 24	M = 163 Nm
1125	Locking nuts of connecting rod clamping bolts	M 14 / SW 22 M 12 / SW 19	M = 140 Nm M = 66 Nm
1015	Nut of the leaf spring clamps	M 12 / SW 19	M = 66 Nm
1637	Locking nuts of securing bolts for shaped plate at U-stabiliser	M 10 / SW 17	M = 53 Nm

5 Safety regulations, safety information

5.1 Safety regulations

- All work must be performed by trained mechanics at competent repair facilities or authorised specialist companies who have access to all relevant tools and have acquired the knowledge required for this work. Anyone who performs maintenance and repair work must be trained in automotive mechanics and already have experience in repairing trailers. Anyone who performs brake work must be trained in brake systems.
 - Comply with local safety regulations.
 - The relevant operation and service regulations as well as safety regulations of the vehicle manufacturer and of the manufacturers of other vehicle parts must be adhered to.
 - The vehicle must be prevented from moving during repair work. Please observe the relevant safety regulations for repair work on commercial vehicles, in particular the safety regulations for jacking up and securing the vehicle.
 - During repair work, make sure that the brake is not operated inadvertently. The brake must not be applied.
 - Do not perform repair work unless wearing protective clothing (gloves, safety boots, safety goggles, etc.).
 - Only use recommended tools.
 - A second mechanic must provide assistance when working with heavy components (steering pivots, brake discs, brake drums or brake removal/installation).
 - All air lines and components must be depressurised before being removed.
 - Following each repair, perform a function check or a test drive in order to make sure that the brakes and suspensions are functioning correctly. New brake linings only have maximum effect after a few braking actions. Avoid hard braking.
 - All exchanged components must be reused or disposed of in accordance with the applicable environmental regulations, laws and directives.
 - The remaining thickness of the brake lining and the condition of the brake disc or brake drum must be visually inspected at regular intervals depending on the way in which the vehicle is used (see BPW maintenance instructions).
 - Tighten all fixings to the recommended tightening torque.
-

5.2 Safety information

This workshop manual contains different types of safety instructions, each of which is designated an icon and a key word. The key word describes the severity of the potential danger.



Caution! Possible dangerous situation (slight injury or damage to property).



Repair Guide! Risk of damage to property or consequential damage if this information is not observed.



Note! Application hints and especially useful information.

It is essential that all maintenance work is carried out in accordance with the prescribed intervals in order to maintain the safe operation and roadworthiness of the trailer. The relevant operation and service regulations of the vehicle manufacturer and of the manufacturers of other vehicle parts must also be adhered to. Rectification of any defects which are discovered or replacement of worn parts should be carried out by a BPW Service Centre or BPW Direct Service Partner unless the vehicle owner has the facilities, equipment and workshop manuals and possesses an official certificate to perform interim inspections or special brake inspections.

When installing spare parts, it is strongly recommended that only original BPW components are used. Parts approved by BPW for trailer axles and suspensions regularly undergo special test procedures. BPW accepts product responsibility for them.

However, BPW cannot assess every single third-party product as to whether it can be used for BPW trailer axles and suspensions without any risk to safety. This applies even if such products have already been tested by an accredited test authority.

The warranty becomes null and void if spare parts other than original BPW parts are used.

6 Care and Maintenance

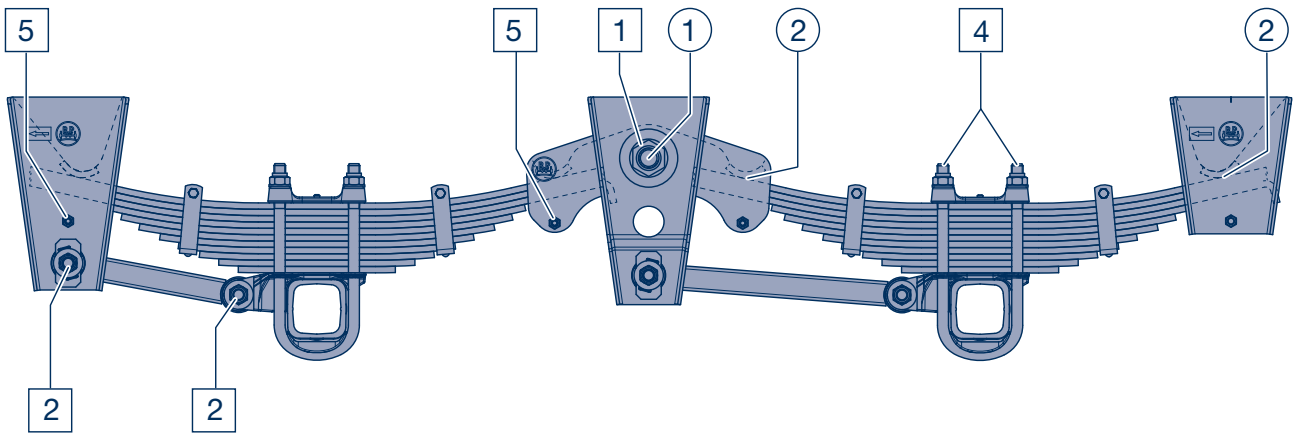

ECO Cargo VB ...M ...ME EC

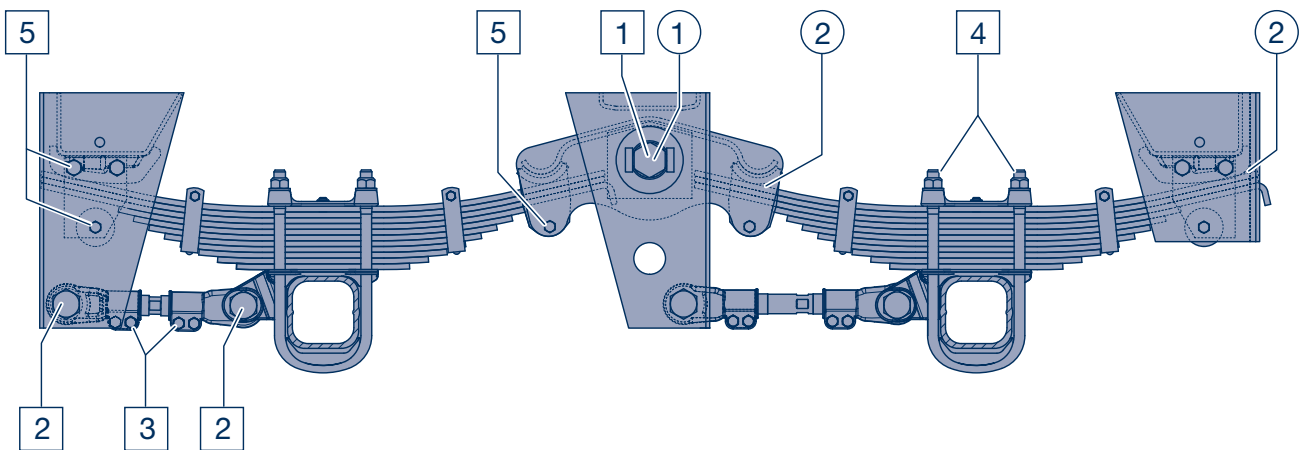

ECO Cargo VB HD / HDE

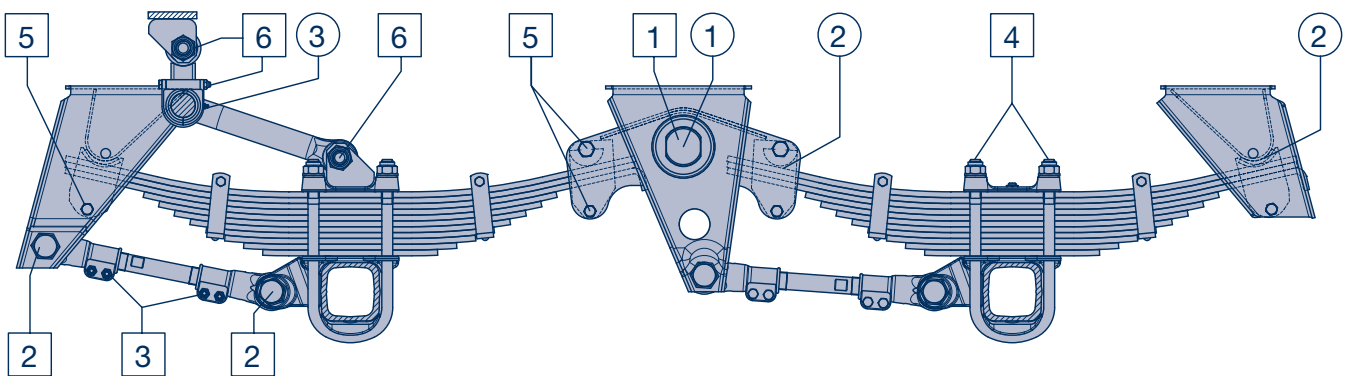

Version up to 07/2013, here with stabiliser

Lubrication and maintenance work

Overview

Lubricate

Maintenance work

For detailed description see pages 18 and 21

		initially	every 6 weeks	twice annually ¹⁾	annually ¹⁾
<input type="radio"/> ①	Grease equalising beam bearings (suspension type E) with special longlife grease ECO-Li ^{Plus} . (Not applicable in the case of rubber-steel bushes)	①	①		
<input type="radio"/> ②	Lightly grease the slide elements/slide ends of springs.	②	②		
<input type="radio"/> ③	Grease stabiliser bearing bushes with BPW special longlife grease ECO-Li ^{Plus} and check for wear.	③			③
<input type="checkbox"/> 1	Check threaded bolts on equaliser beam bearings for firm seating. up to an axle load of 12 tonnes (from 08/2013) M 42 x 3 / SW 65 M = 1300 Nm up to an axle load of 12 tonnes (up to 07/2013) M 42 x 3 / SW 65 M = 1100 Nm from an axle load of 13 tonnes M 42 x 3 / SW 65 M = 1700 Nm Series HD / HDE M 48 x 3 / SW 65 M = 1200 - 1300 Nm			<input type="checkbox"/> 1	
<input type="checkbox"/> 2	Check axle connecting rod bolts for firm seating using a torque wrench. M 24 x 2 / SW 36 M = 650 Nm M 30 / SW 46 M = 725 Nm M 36 / SW 55 M = 1425 Nm	<input type="checkbox"/> 2		<input type="checkbox"/> 2	
<input type="checkbox"/> 3	Check connecting rod clamping bolts for firm seating. M 12 / SW 19 M = 66 Nm M 14 / SW 22 M = 140 Nm			<input type="checkbox"/> 3	
<input type="checkbox"/> 4	Check spring U-bolts for firm seating using a torque wrench M 24 / SW 36 M = 600 - 650 Nm	<input type="checkbox"/> 4		<input type="checkbox"/> 4	
<input type="checkbox"/> 5	Check slide elements for firm seating. M 14 / SW 22 M = 140 Nm M 20 / SW 30 M = 320 Nm			<input type="checkbox"/> 5	
<input type="checkbox"/> -	Visual inspection. Check all component parts and welding seams for wear and damage.			<input type="checkbox"/> -	
<input type="checkbox"/> 6	Check the stabiliser attachments. M 10 / SW 17 M = 53 Nm M 30 / SW 46 M = 700 - 750 Nm				<input type="checkbox"/> 6

¹⁾ Under extreme conditions, with more frequency.

Note:

Components that have damage due to improper mounting are to be replaced after a review by a BPW Service Centre.

6 Care and Maintenance

- Lubrication work
- Maintenance work

- ① **Equalising beam bearings with bronze bushes**
(Series ECO Cargo VB ME and ECO Cargo VB HDE)
- initially after 2 weeks then every 6 weeks -
 - under extreme conditions, lubricate with more frequency -

Lift trailer to take pressure off equaliser beam bearings.

Grease bronze bush bearing via the grease nipple in the heads of the threaded bolts with BPW special longlife grease ECO-Li^{Plus} until fresh grease emerges. (Not applicable to rubber-steel bushes.)

At extremely low temperatures (-30° C to -50° C) a grease with correspondingly lower consistency class should be used - such as BPW ECO-Li Polar.

- ② **Lightly grease slide elements and slide ends of the leaf springs.**
- initially after 2 weeks then every 6 weeks -
 - under extreme conditions, lubricate with more frequency -

Clean and lightly grease the slides / slide ends of the springs.

In the case of ECO Cargo VB suspensions (up to 07/2013) with anti-vibration leaf underneath the parabolic springs, grease the lower slide elements via the grease nipples (arrow).



Note:
When exposed to highly abrasive particles (e.g. coal dust), we recommend not applying grease to avoid dust from sticking to components.

- ③ **Stabiliser bearing bushes**
- annually, initially after 2 weeks -
 - under extreme conditions, lubricate with more frequency -

Grease stabiliser bearing bushes with BPW special longlife grease ECO-Li^{Plus} and check for wear.

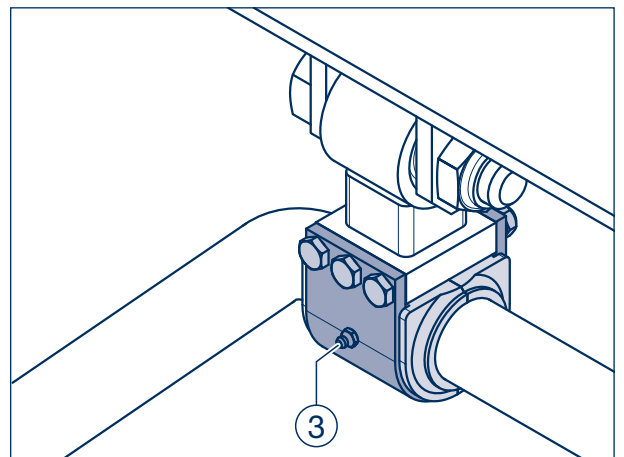
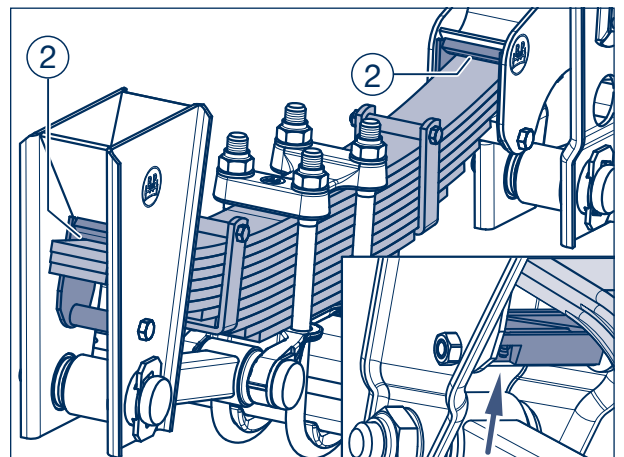
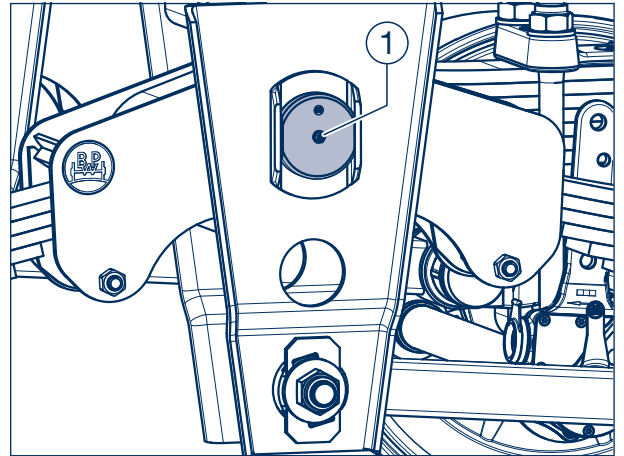

1 Equaliser beam bearings

– twice annually –

Check nuts on the equaliser beam bearings for firm seating. The service life of the rubber-steel bush bearings is dependent on the firm seating of the inner steel bush.

Tightening torques:

up to an axle load of 12 tonnes (from 08/2013)

M 42 x 3 (SW 65) M = 1300 Nm

up to an axle load of 12 tonnes (up to 07/2013)

M 42 x 3 (SW 65) M = 1100 Nm

from an axle load of 13 tonnes

M 42 x 3 (SW 65) M = 1700 Nm

Series HD / HDE

M 48 x 3 (SW 65) M = 1200 - 1300 Nm

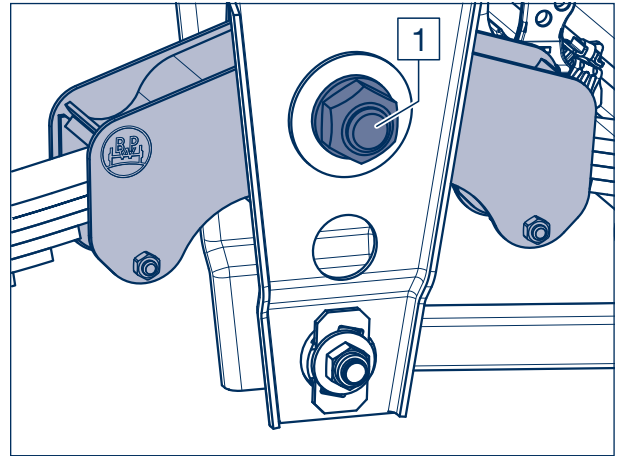
**2 Axle connecting rods**

– twice annually, initially after 2 weeks –

Check lock nuts of the axle guide linkages / connecting rods for firm seating using a torque wrench.

Tightening torques:

M 24 x 2 (SW 36) M = 650 Nm

M 30 (SW 46) M = 725 Nm

M 36 (SW 65) M = 1425 Nm

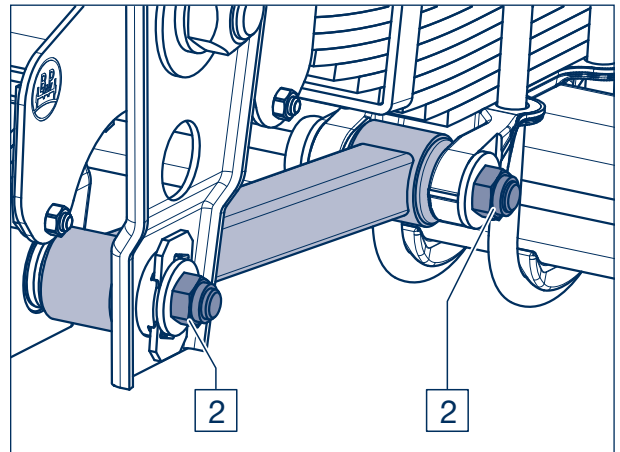
**3 Connecting rods** (only for series VB up to manufacturing year 08.2013 and ECO Cargo VB HD)

– twice annually –

Check connecting rod clamping screws for tightness.

Tightening torques:

M 12 (SW 19) M = 66 Nm

M 14 (SW 22) M = 140 Nm

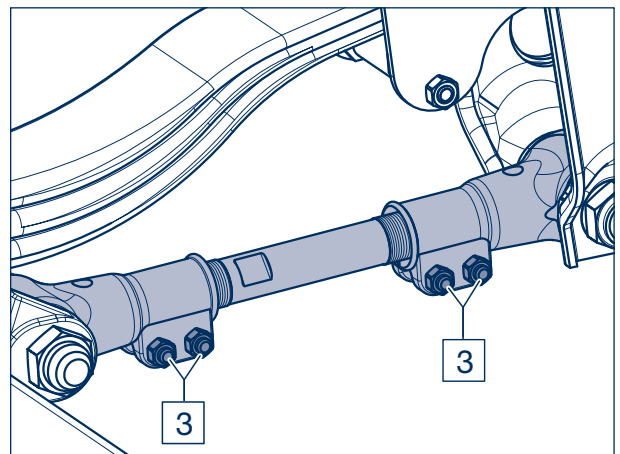

6 Care and Maintenance

4 Spring U-bolts

– twice annually, initially after 2 weeks –

Check spring U-bolts for tightness. If necessary loosen lock nuts, tighten nuts alternately to the prescribed torque, and a bit at a time, if necessary then re-lock.

Tightening torque:

M 24 (SW 36)

M = 600 - 650 Nm

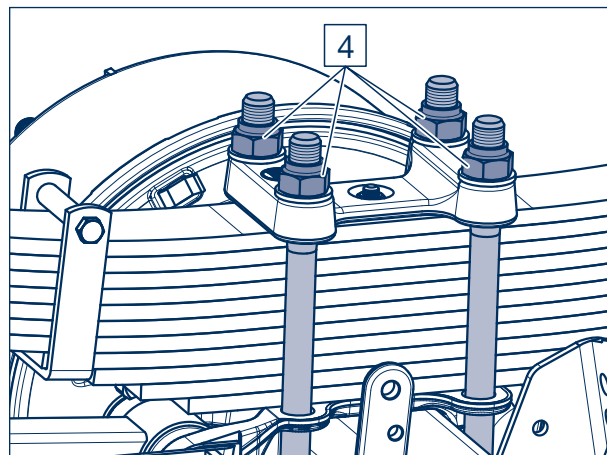

5 Slide elements

– twice annually –

Check slide elements and lateral wear plates in the shackle and equaliser beam for wear and the fastening screws for firm seating.

Tightening torques:

M 14 (SW 22)

M = 140 Nm

M 20 (SW 30)

M = 320 Nm

If necessary, check rubber rollers under the spring ends for wear.

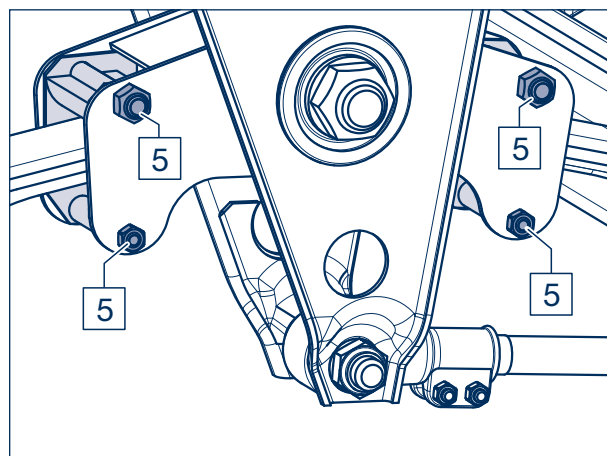
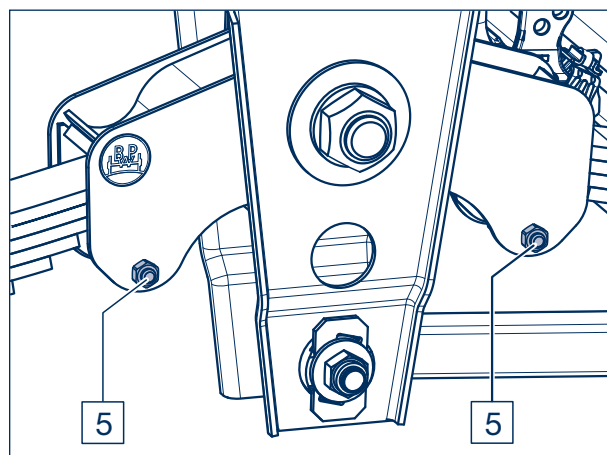

- Visual inspection

– twice annually –

Check all component parts and welding seams for wear and damage.

In order to check the bearing on the equaliser and axle guide linkage, move the vehicle back and forth slightly with the brake applied; or move the bearing points with the aid of a lever. No play should be present in the bearing when doing so.

6 Stabiliser

– annually –

Check stabiliser bearings for wear and firm seating.

Tightening torques:

M 10 (SW 17)

M 30 (SW 46)

M = 53 Nm

M = 700 - 750 Nm

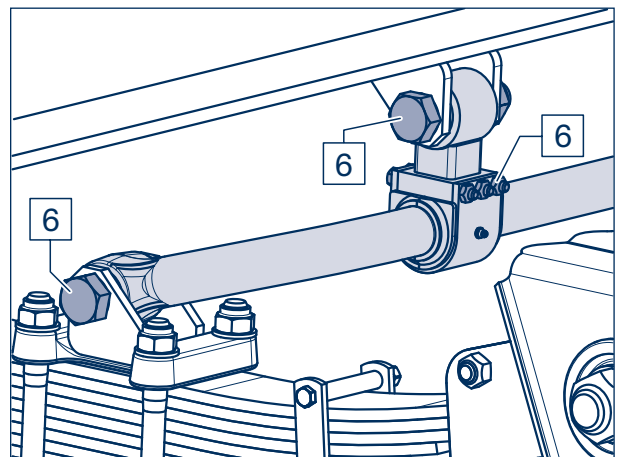

7 Removing and installing axle with leaf springs

7.1 Removing

- [1] Safely support the vehicle frame.
- [2] Slightly raise axle with vehicle lift and support in secure position. Dismantle wheels.
- [3] Deactivate brakes. Dismantle air brake pipes for brake cylinder or air brake chamber (steering axle) and tension cable for parking brake.
- [4] Unscrew locking nuts (1168, SW 36 / SW 46 / SW 55) from the securing bolts (1154) of the left and right connecting rod (1100, 1105).

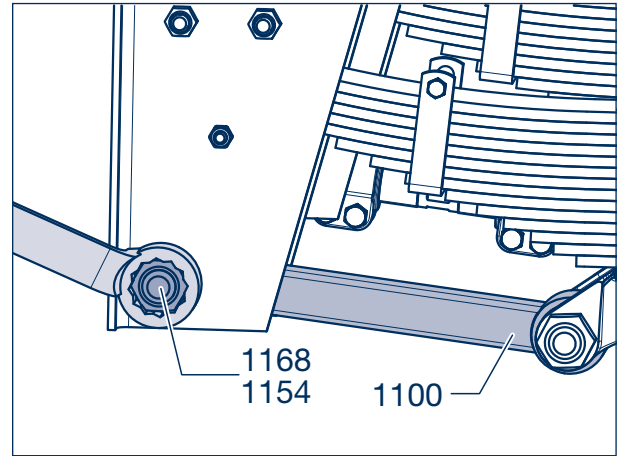

Picture 1

- [5] In the ECO Cargo version with track adjustment on the hanger bracket, remove the washers (1165) and the link discs (1161) from the bolts (1154).



Repair guide!

When the link discs are tacked on, the tack-weld points must be removed if necessary.

- [6] In ECO Cargo with link discs, remove the bolts (1154), from the hanger brackets and tie rods (1100, 1105).

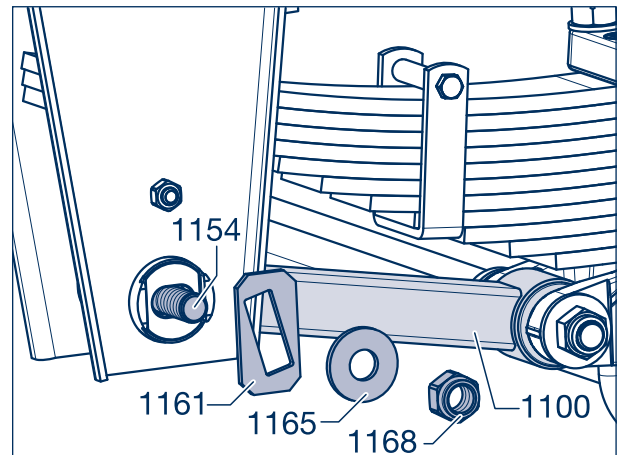

Picture 2

- [7] If axles with U-stabiliser (1815) are fitted, the securing bolts (1156) at the spring plates (1032, 1033) must be removed.

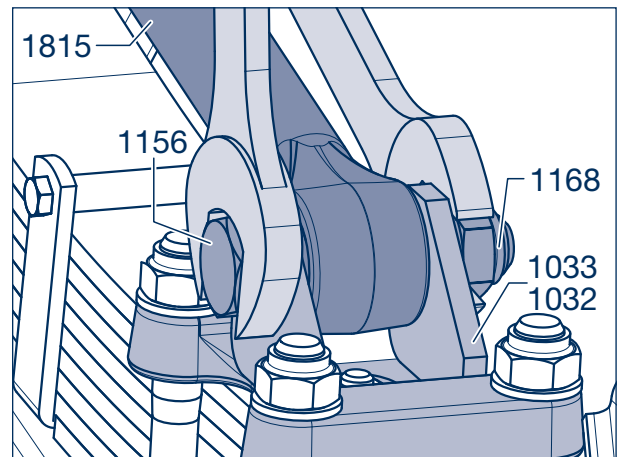

Picture 3

**- Multi-leaf spring /
parabolic spring without anti-vibration leaf:**

- [8] Unscrew lock nuts (1238, SW 22) from the fixing bolts (1235) on the equalising beam (1320, 1326, 1327) or the hanger bracket.
- [9] Take out the securing bolts (1235).
- [10] Take the tube (1245) with bush, if necessary (1410, 1412) out of both sides of the equaliser or support.

 Continue with work step [11].

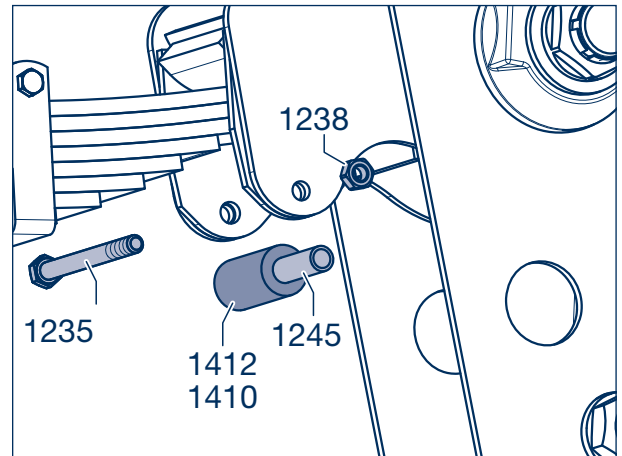

Picture 4

- Parabolic spring with anti-vibration leaf:

- [8] Clamp the spring parts of the leaf spring (1000) together.
- [9] Unscrew lock nuts (1238, SW 22) and remove the fixing bolts (1235) from the equalising beam and or the hanger bracket.
- [10] Take out slider (1415) with tube (1245).

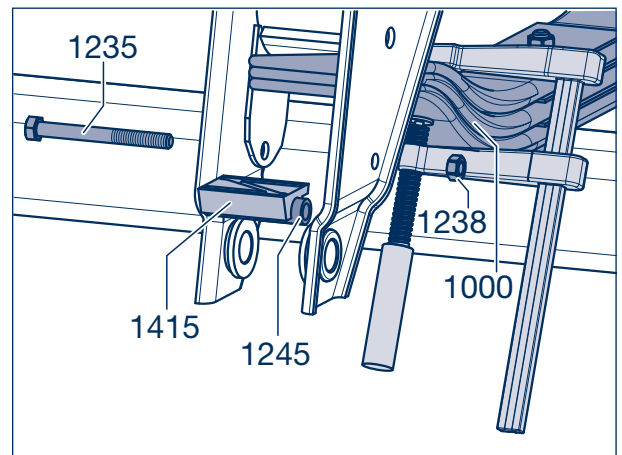

Picture 5

- [11] Lower the axle and pull out.



Caution! RISK OF INJURY
Protect the axle from falling off the jack. When lowering, leave sufficient room under the vehicle.

- [12] Check bushes (1117) in the connecting rods (1100, 1105) for wear, if necessary remove connecting rod and change bushes.

 See Chapter 7.3 on page 27 for installation.

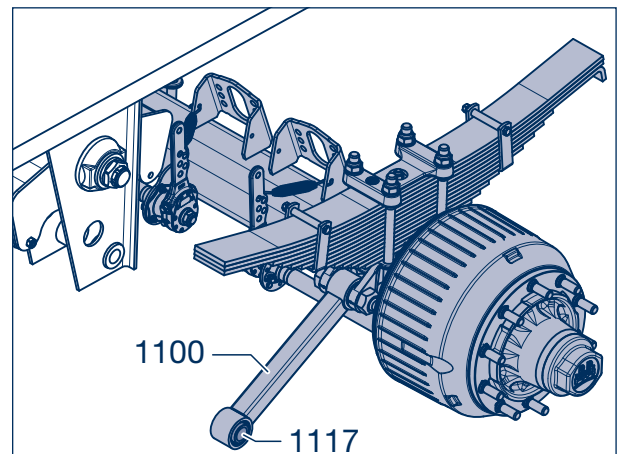

Picture 6

7 Removing and installing axle with leaf springs

7.2 Replacing the bushes in the connecting rods

- Connecting rods version VB...EC:



Note:
ECO Cargo version connecting rods must be removed and the bushes pressed out or in.

- [13] Align connecting rod (1100, 1105) under a press.
- [14] Press bush (1117) with a stepped bolt, \varnothing approx. 22/45 mm, from the connecting rod.

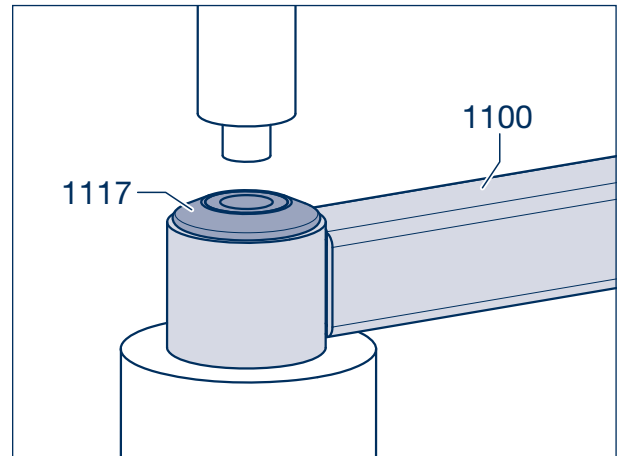

Picture 7

- [15] Align eye of the connecting rod (1100, 1105) in the centre on a backing with a hole diameter of approximately 66 mm.
- [16] Insert push-in tool (BPW No. 15.009.19433) with the phase (arrow) in the connecting rod eye.

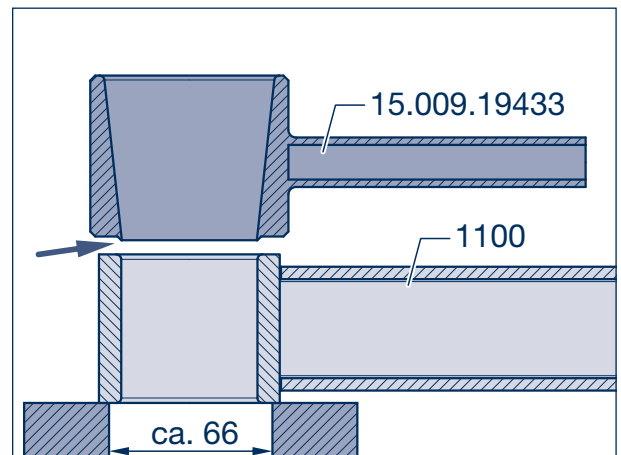

Picture 8

- [17] Coat rubber-steel bush (1117) with soapy water or tyre fitting paste and insert it into the tool.
- [18] Push the bush in with the stepped bolt until the push-in tool releases.

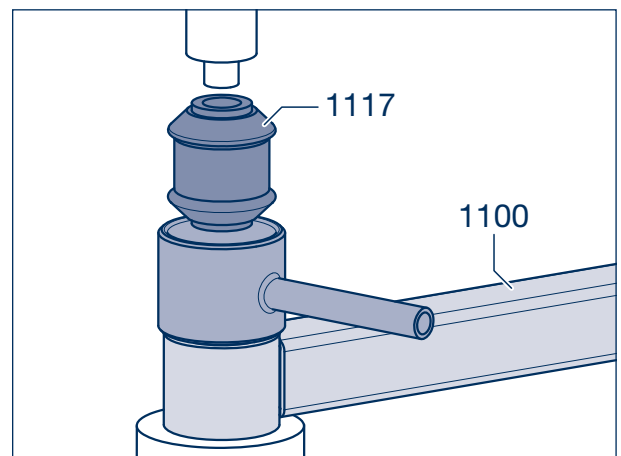

Picture 9

- [19] Remove push-in tool and stepped bolt. Rotate connecting rod and, if necessary, push the bush (1117) in a little in the opposite direction.



Repair guide!
The projection on both sides must be the same

- Continue with work step [29].

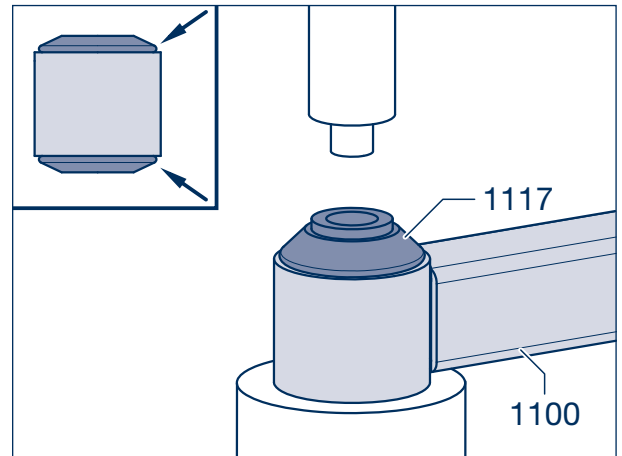

Picture 10

- All other suspension types:



Note:
The pressing in or out can be carried out under a press or with a drawing tool.

Push in under a press

- [20] When pushing in under a press, coat the rubber-steel bush (1117) with soapy water and insert into the assembly tool.

BPW No.:	Ø 60	15.003.19433
	Ø 66	15.004.19433

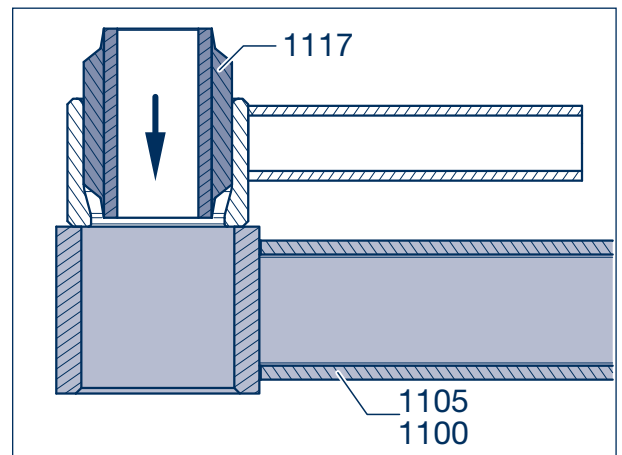

Picture 11

- [21] Press in bush (1117) with appropriate pressure sleeve until the projecting end is the same on both sides (picture 12/arrows).

- Continue with work step [29].

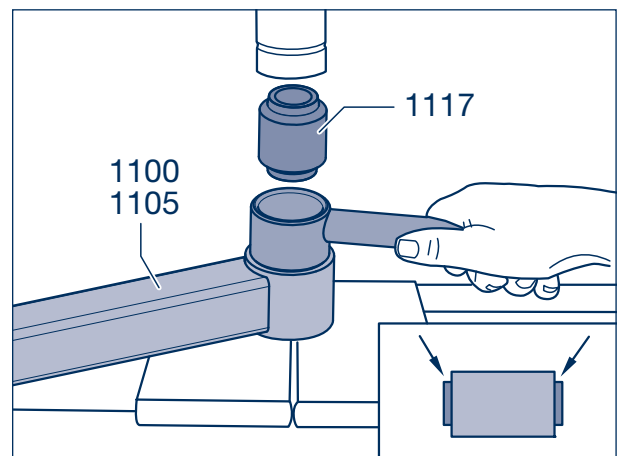

Picture 12

7 Removing and installing axle with leaf springs

Replace the bush with a pull-out and pull-in device.

- [22] When exchanging the bushes (1117) with a drawing tool (BPW No. 14.825.11744), insert the screw (1) with washer (2) into the rubber-steel bush.
- [23] Position tube (3) and thrust piece (4). Fit nut (5) with spring washer (6).
- [24] Withdraw rubber-steel bush (1117).

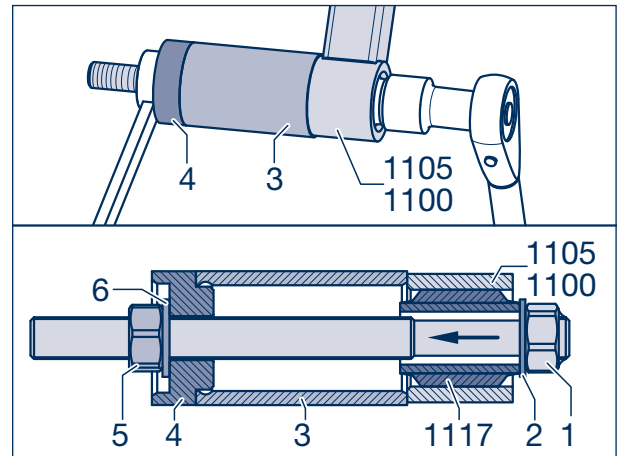

Picture 13

- [25] Coat new bonded rubber-steel bush (1117) on the outside with soapy water and insert into the tube (3).
- [26] Insert the tube so that the inner ring groove (arrow) is on the chamfered side of the connecting rod eye (1100, 1105).
- [27] Push in bolt (1) with washer (2).
- [28] Fit thrust piece (4), fit nut (5) with spring washer (6) and draw bonded rubber-steel bush (1117) into the connecting rod.



Repair guide!

The projection on both sides must be the same (picture 12/arrows).

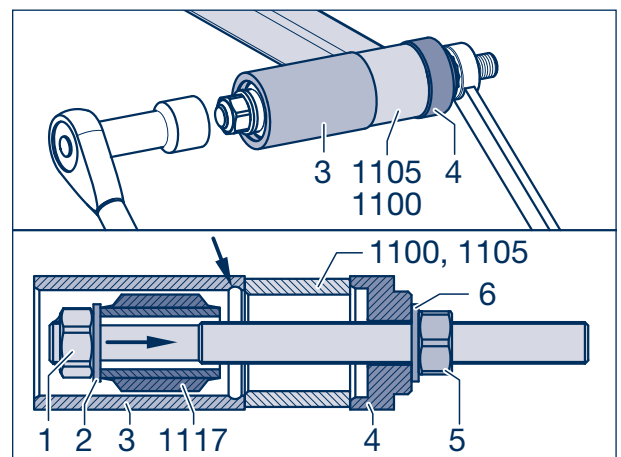

Picture 14

- [29] Loosen bolts (1123, SW 19 / SW 22) of the connecting rod ends (1115, 1116) and check the bolt (1) of the connecting rod for smooth action. If necessary, remove the bolt, clean it thoroughly, and apply BPW special longlife grease ECO-Li^{Plus} to the thread.
- [30] Assemble the connecting rod (1100, 1105), paying attention to the right and left thread. Screw in connecting rod ends equally.



Repair guide!

The securing bolts (1123) will be secured after the axle alignment check (see chapter 11 / 12).

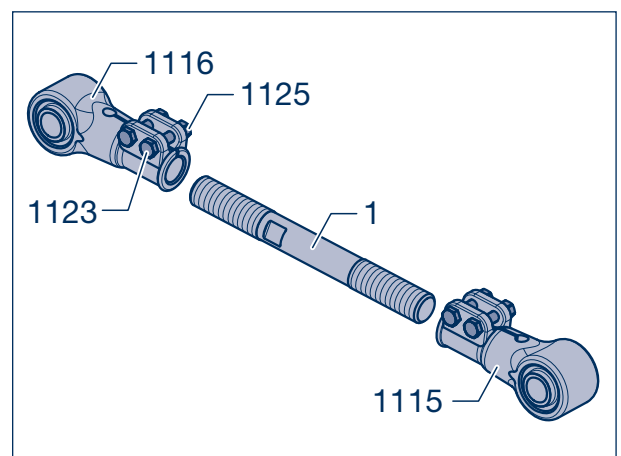

Picture 15

7.3 Installing

- [31] Check the support plate (1230) in the equalising beam and the slippers in the hanger bracket for wear, see chapter 10.
- [32] Place axle securely on vehicle lift, push under vehicle and raise. Align axle with leaf springs and insert into the equalising beam or support.

- **Multi-leaf spring / parabolic spring without antivibration leaf:**

- [33] Check tube (1245) if necessary with bush (1410, 1412) for wear, use new one as appropriate and insert into the equalising beam or support. Insert securing bolt (1235).

- [34] Fit new locking nuts (1238) and tighten to the specified torque.

Tightening torques:

M 14 (SW 22)	M = 140 Nm
M 20 (SW 30)	M = 320 Nm

-  Continue with work step [37] on page 28.

- **Parabolic spring with anti-vibration leaf:**

- [33] Check the slipper (1415) and replace, if necessary. Press in the greased tube (1245).

- [34] Clamp the spring parts together.
- [35] Insert slider (1415) with securing bolt (1235), grease nipple (arrow) pointing to axle.
- [36] Fit new locking nut (1238) and tighten to the specified torque.

Tightening torques:

M 14 (SW 22)	M = 140 Nm
M 20 (SW 30)	M = 320 Nm

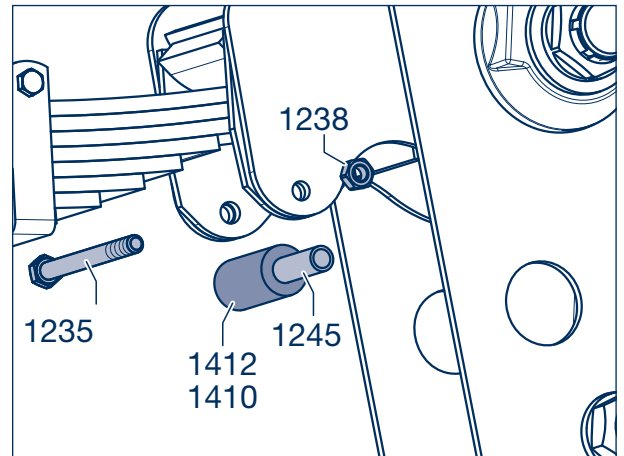

Picture 16

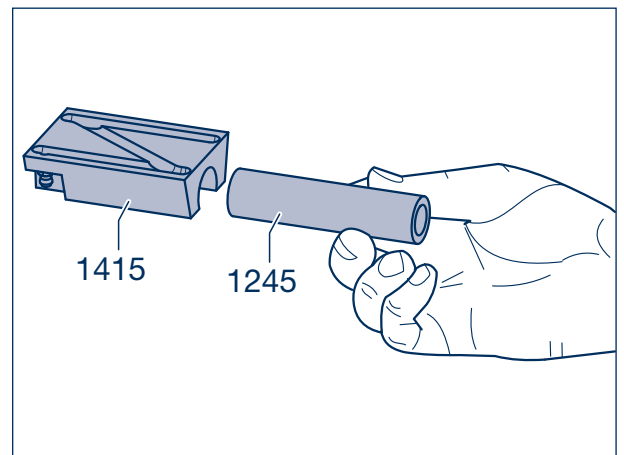

Picture 17

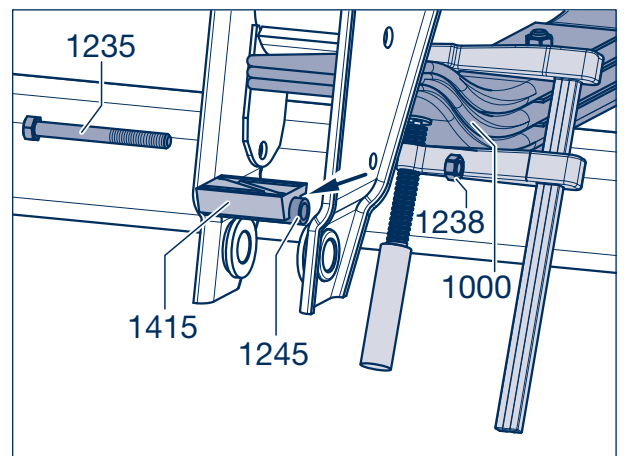

Picture 18

7 Removing and installing axle with leaf springs

- Suspension versions up to 07.2013 and VB...HD / HDE

- [37] Assemble connecting rods with securing bolts (1154) to the equalising beam or support (according to design) and to the axle.



Repair guide!

For the equalising beam or support design with anti-rotation lock (1167), insert the connecting rod end into the shaped plate.

- [38] Fit new locking nuts (1168) and tighten to the specified torque.

Tightening torques:

M 30 (SW 46)	M = 725 Nm
M 36 (SW 55)	M = 1425 Nm

- Continue with work step [43] on page 29.

- Suspension versions VB...EC:

- [37] Align hanger bracket bushes (1205) and connecting rod (1100).
- [38] Install washers (1165) between the connecting rods and the hanger bracket.

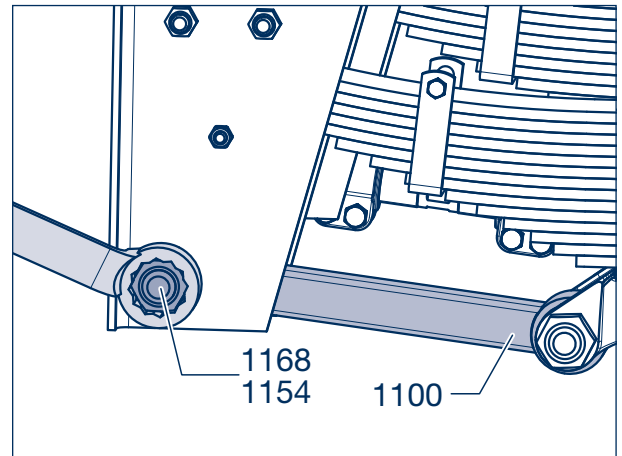

Picture 19

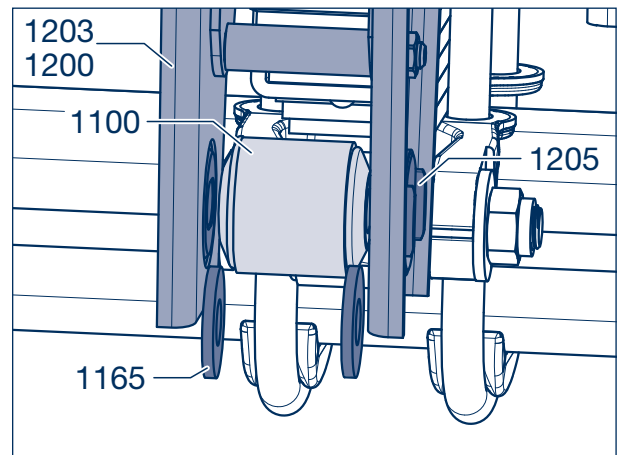

Picture 20

- [39] Push link disc (1161) onto the fixing bolt (1154). Make sure that the link disc is correctly positioned.
- [40] Smear fixing bolt with grease and install with the pushed-on link disc in the hanger bracket / connecting rod from the inside out. The link disk must engage in the jaws of the hanger bracket.

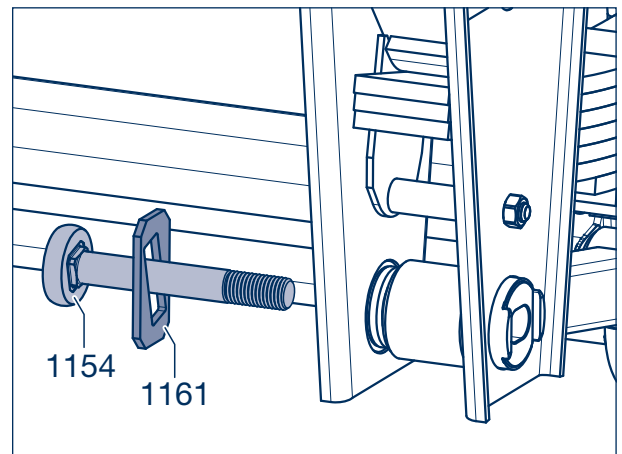

Picture 21

- [41] Install link disc (1161), washer (1165) and new lock nut (1168). The bevels of the link discs must be aligned to each other and engage on both sides in the jaws of the hanger bracket.



Repair guide!
Do not tighten lock nuts!

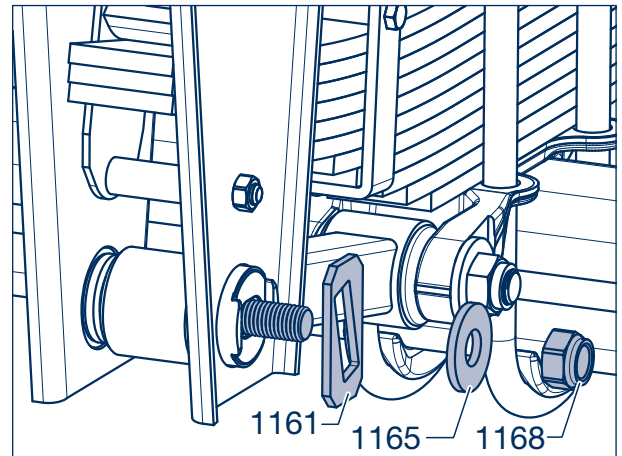

Picture 22

- [42] On both sides, align the centre link discs (1161) and lock nuts (1168, SW 36) slightly tighten - do not tighten.
(The bolts are tightened when the axle tracking has been adjusted).

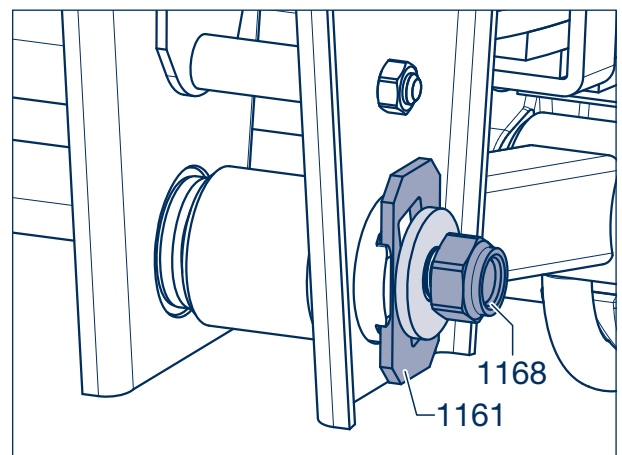

Picture 23

- [43] Attach air brake pipes to brake cylinder or air brake chamber (steering axle) and cable for parking brake.
- [44] Fit wheels.
- [45] Lubricate slider (1415, arrow) on axles with anti-vibration leaf with BPW special long-term grease ECO-Li^{Plus}, until fresh grease emerges.



Repair guide!
After removing the axle or exchanging suspension parts, an axle alignment check must be carried out (see chapter 11 / 12).

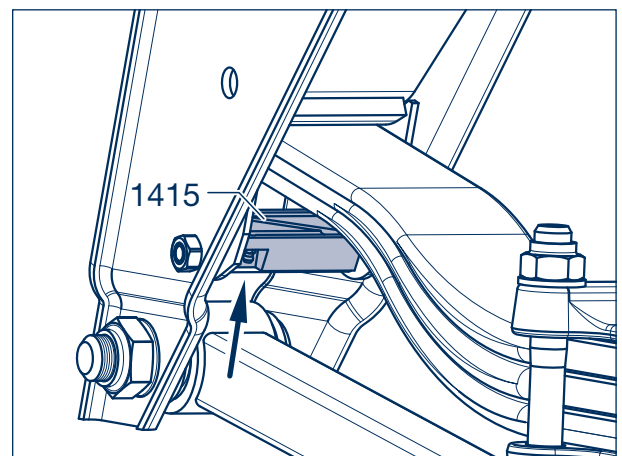

Picture 24

8 Removing and installing U-stabiliser

Removing

- [1] Unscrew locking nuts (1637, SW 17) from the securing bolts (1645) of the shaped plate (1642).
- [2] Remove securing bolts.
- [3] Take off shaped plate (1642) and split bush with seals (1641).

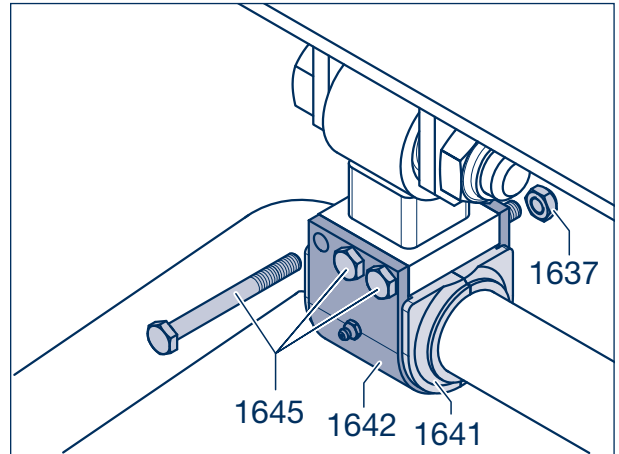

Picture 1

- [4] Unscrew locking nuts (1168, SW 46) from the securing bolts (1156) at the spring plates (1032, 1033) and remove securing bolts.
- [5] Take off U-stabiliser (1815).

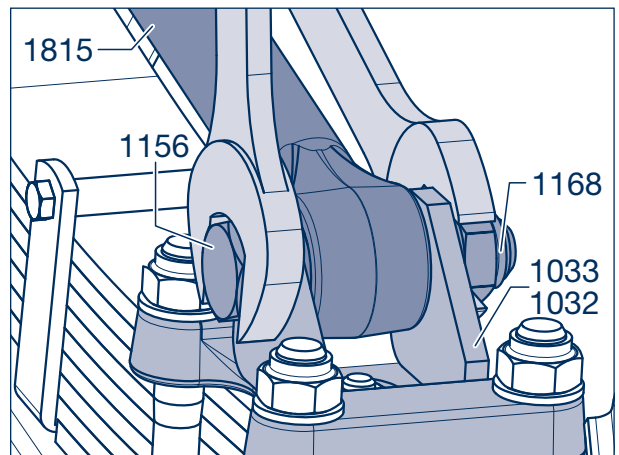

Picture 2

- [6] Examine bonded rubber bushes (1817) in U-stabiliser (1815) for signs of wear, replace if necessary with assembly tool (BPW No. 14.825.11744), see also Chapter 7, step [22] - [28].

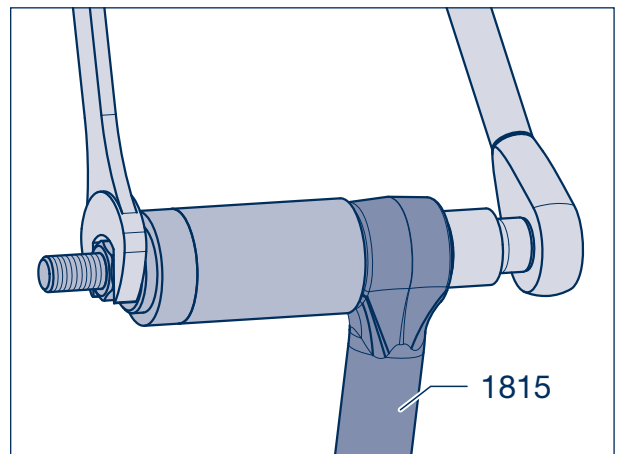

Picture 3

- [7] If necessary, remove bracket (1820) for U-stabiliser by unscrewing locking nut (1168, SW 46) of securing bolt (1156), withdrawing securing bolt and taking off bracket.
- [8] Examine bonded rubber in bracket for signs of wear, replace if necessary with assembly tool (BPW No. 15.002.19433) or press out and in under a press, see Chapter 7, step [20].

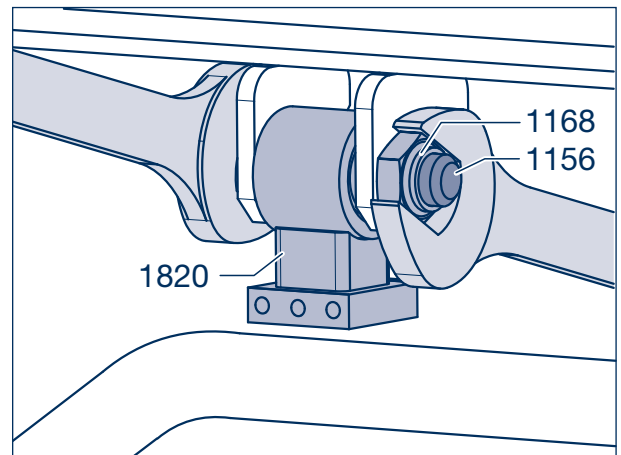

Picture 4

Installing



Note:

The surface of the U-stabiliser (1815) in the area of the bushes must be free of rust.

- [9] If demounted, refit retainer (1820) for U-stabiliser (picture 4) and screw new lock nuts (1168, SW 46) onto the hexagon screws (1156) by hand. Do not tighten.
- [10] Fit U-stabiliser (1815) onto the spring plates (1032, 1033) and push in securing bolts (1156).
- [11] Fit new lock nuts (1168). Do not tighten.

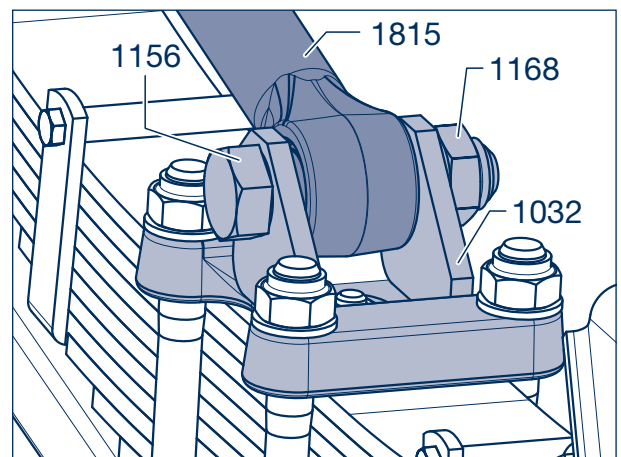

Picture 5

- [12] Examine split bush (1641) and seals for sign of wear, fit new parts if necessary.
- [13] Smear split bush with BPW special longlife grease ECO-Li^{Plus}.

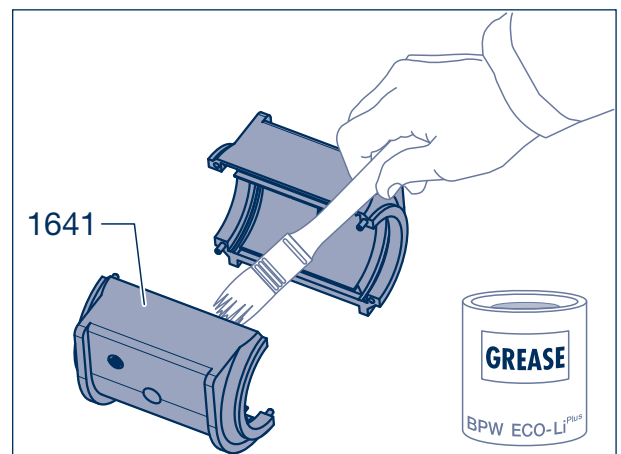

Picture 6

8 Removing and installing U-stabiliser

- [14] Fit seals onto U-stabiliser and hold tight.
- [15] Fit split bush (1641) so that the seals are located in the grooves (arrow).

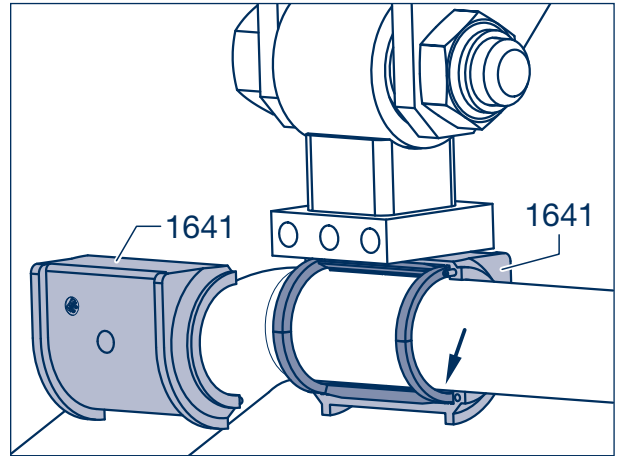

Picture 7

- [16] Fit shaped plate (1642) onto the split bush (1641).

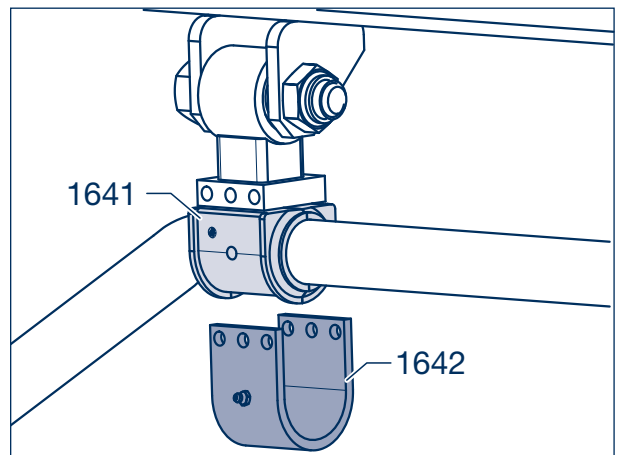

Picture 8

- [17] Insert securing bolts (1645) of the shaped plate (1642), screw on new locking nuts (1637, SW 17) and tighten to the specified torque of 53 Nm.
- [18] Lubricate the bearing with BPW special longlife grease ECO-Li^{Plus} via the lubrication nipple (1347).
- [19] Tighten the lock nuts (1168, SW 46) of the hexagon bolts (1156) (pictures 5 and 9) to the specified torque of 700 - 750 Nm.

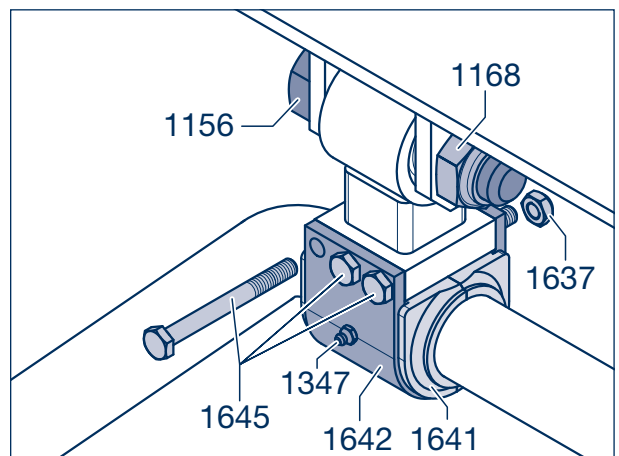

Picture 9

Removing and installing leaf springs

9

Removing

- [1] Remove axle with leaf spring, see chapter 7 work procedures 1-12.
- [2] Unscrew the double nuts or the self-locking nuts (1057, SW 36) from the U-bolts. Remove the washers (1055). Remove spring plates (1032, 1033) and remove the spring U-bolt (1050).
- [3] Remove leaf spring (1000) from the axle.



Note:

Parabolic and multi-leaf springs can be installed.

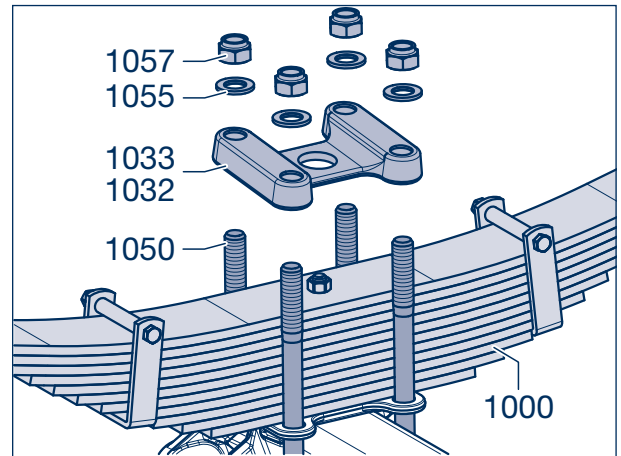

Picture 1

- [4] Take apart corroded leaf springs (1000). Unscrew hexagon nut (1011, SW 24) and remove spring screw (1010).
- [5] Unscrew nuts (1015, SW 19) from hexagon bolts (1014) and remove spring clips (1012).
- [6] Thoroughly clean each leaf with a wire brush and inspect it for cracks. Replace heavily corroded spring leaves and those having cracks. Change the top spring leaf when the wear is more than 20% of the leaf thickness.
- [7] Apply graphite grease to the cleaned spring leaves.
- [8] Insert centre bolt and tighten nut with the prescribed torque of 163 Nm.
- [9] Place spring clamps (1012) over the spring leaves and insert distance sleeve (1016).
- [10] Insert hexagonal screws (1014). Fit nuts (1015), tighten with the prescribed torque of 66 Nm and secure with a counter-nuts.

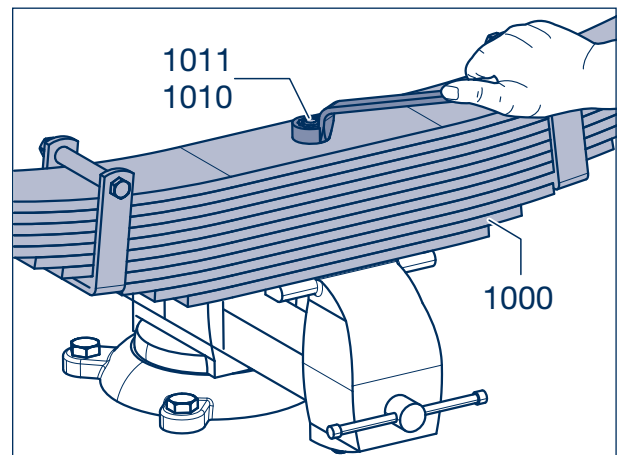

Picture 2

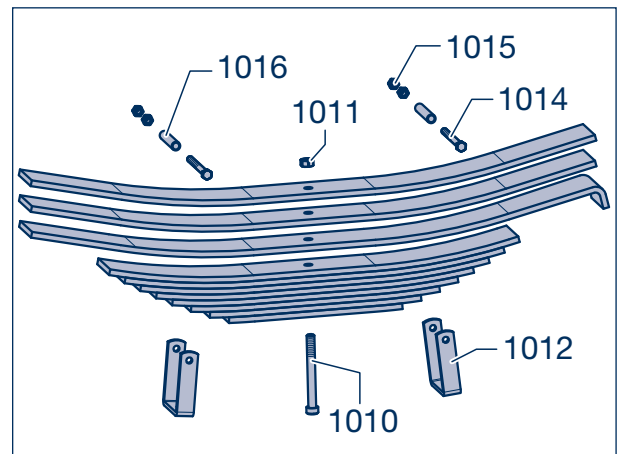

Picture 3

9 Removing and installing leaf springs

Installing



Note:
Spring leaves (multi-spring leaves) with only one hook end must be assembled with the hook to the rear.

- [11] Place the spring (1000) with the spring centre bolt head into the bore of the spring seat.
- [12] Insert U-bolt (1050) with segment (1035) into the spring pad.

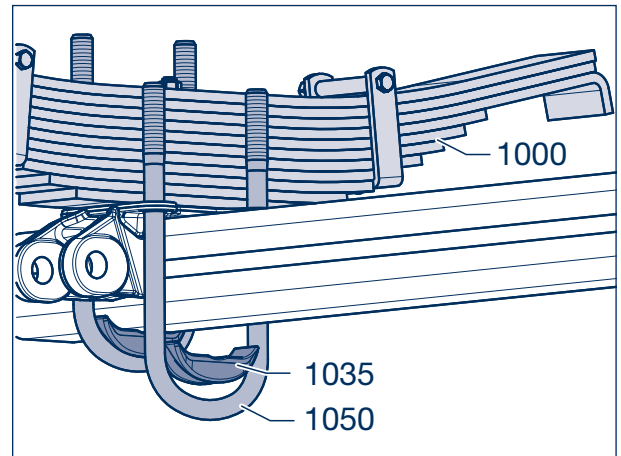

Picture 4

- [13] Fit spring plate (1032, 1033).
- [14] Lightly grease the M 24 threads of the U-bolts (1050).
- [15] Attach the washers (1055) and fit the lock nuts M 24 (1057, SW 36).
- [16] Tighten the lock nuts with the prescribed torque in even stages to 600 - 650 Nm.

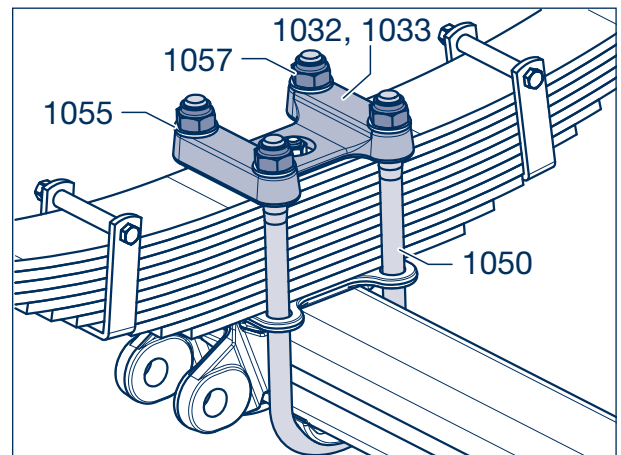

Picture 5

Removing and installing equalising beam 10

10.1 Removing equalising beam



Note:

To remove the equalising beam, remove the centre axle, or the rear axle in case of a tandem axle suspension, and loosen the connecting rods of the second axle.

- [1] Depending on the version, unscrew the lock nut (1244, SW 30) from the fixing bolt (1240). Pull fixing bolt from the support (1230) on the arm.

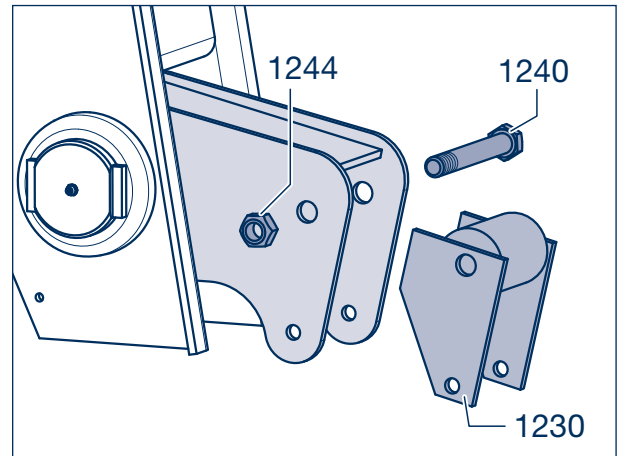

Picture 1

- [2] Check supports (1230) (sliders with wear covers) for wear. Upon reduction of the thickness of the guide rod by 50 % of the total thickness, the supports must be exchanged.

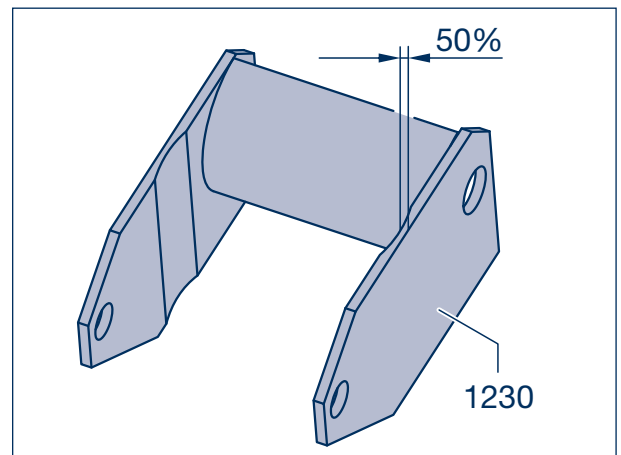

Picture 2

- [3] If welded supports (spring slides) are fitted, chisel or grind off the upper weld seams.

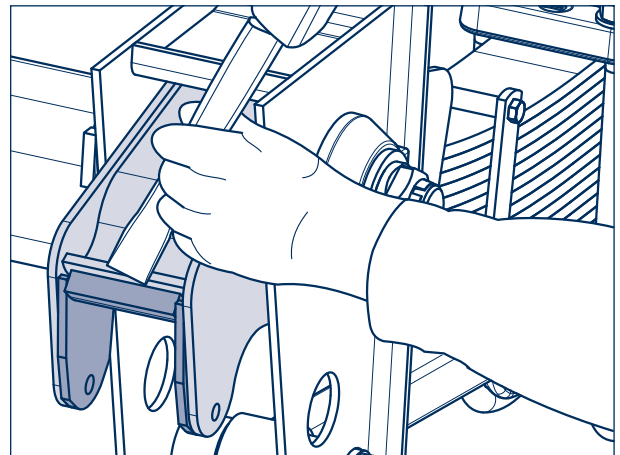

Picture 3

10 Removing and installing equalising beam

- [4] When replacing slide (1230) and plates (1232) of the hanger brackets, unscrew lock nuts (1244, SW 30) from the fixing bolts (1240). Pull out the screws and remove the slide and plates.
- [5] Check slider (1230) and plates (1232) for wear. Upon reduction of the thickness of the plates by 50 % of the total thickness, the plates must be exchanged.

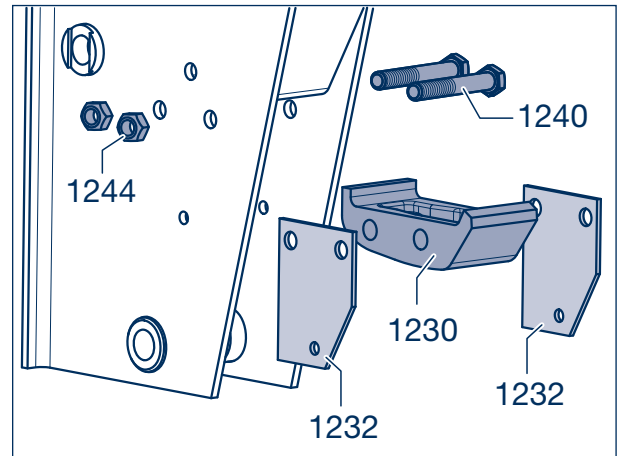

Picture 4

- [6] As necessary, remove the split pin from the threaded bolts (1345) in the equalising beam, remove castle nut or locking nut (1360, SW 65).
- [7] Remove disc (1353) and threaded bolt.

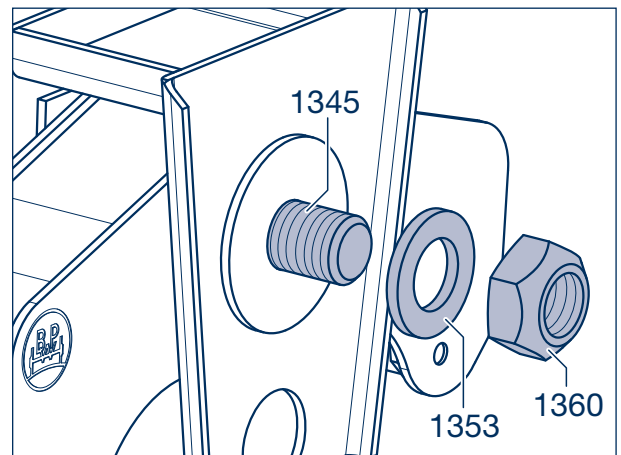

Picture 5

- [8] If the threaded bolt (1345) is seized, weld a hexagonal nut (arrow) on to the middle of the bolt head. Remove threaded bolt with a drawing tool.
- [9] Remove equalising beam, possibly with rings (1350, Figure 15), from the hanger bracket.

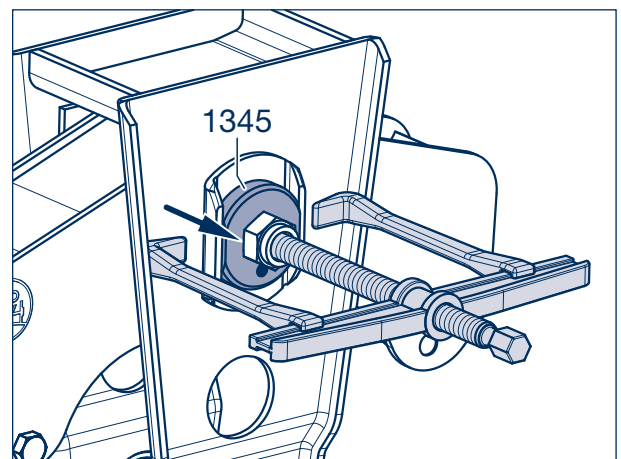

Picture 6

10.2 Replacing bronze bushes

☞ See Chapter 10.3 on page 38 for version with rubber bush.

[10] Check bronze bush (1340) in the equalising beam for wear. As necessary, push out under a press.

Up to 12 t axle load:

[11] Insert new bronze bush (1340) and press in with thrust piece until flush on each side (also see picture 9).

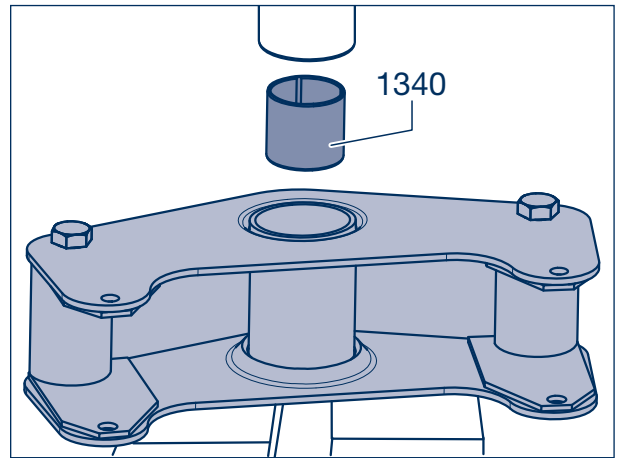

Picture 7

Over 13 t axle load:

[11] Place ring (1350) on the equalising beam. Insert new bronze bush (1340) and press in with thrust piece until flush on each side.



Repair guide!

Do not push the inner bushes (1340) against each other! There must be a space between the two bushes for grease distribution (see picture 9). After installation there must be an excess of 4 mm on both sides.

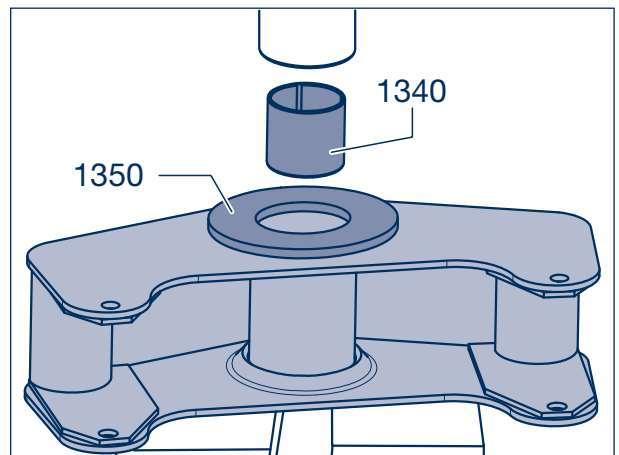

Picture 8

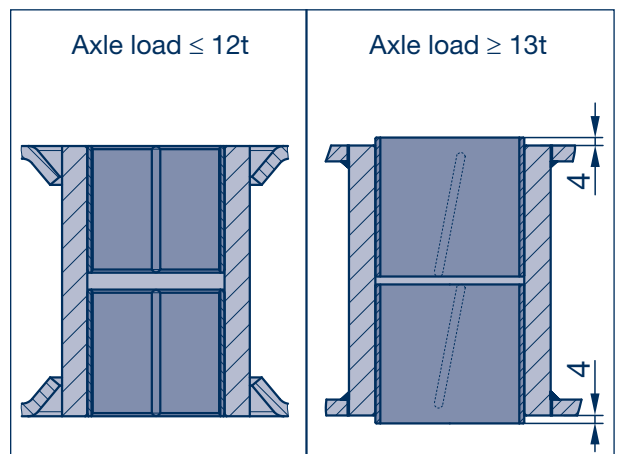

Picture 9

10 Removing and installing equalising beam

Version VB...ME EC

[12] In version VB...EC, smear the inside and outside of the sleeve (1342) with special BPW long-life grease ECO-Li^{Plus} and insert it into the equalising beam.

 For how to install the qualizing beam, see Chapter 10.4 on page 39.

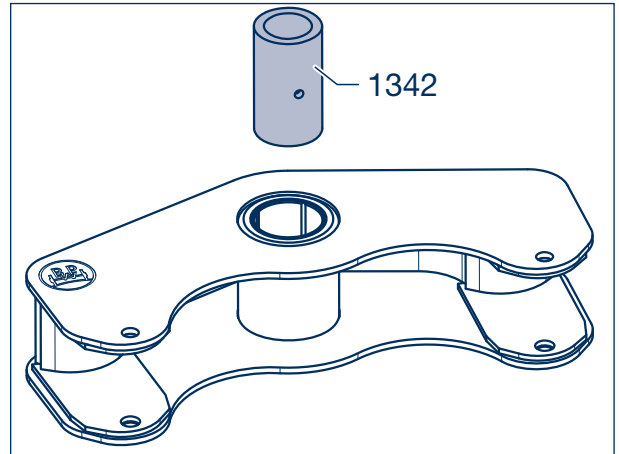

Picture 10

10.3 Replace the rubber-steel bush

[10] Check rubber-steel bush (1340) in equalising beam for wear. Upon detection of wear, push out under a press.

[11] Coat the outside of the new bushes (1340) with soapy water and press into position using the extraction tool and suitable mandrel. After installation there must be an equal excess of the bush on both sides.

BPW code number of extraction tool:

Ø 100	15.006.19433
Ø 107	15.007.19433

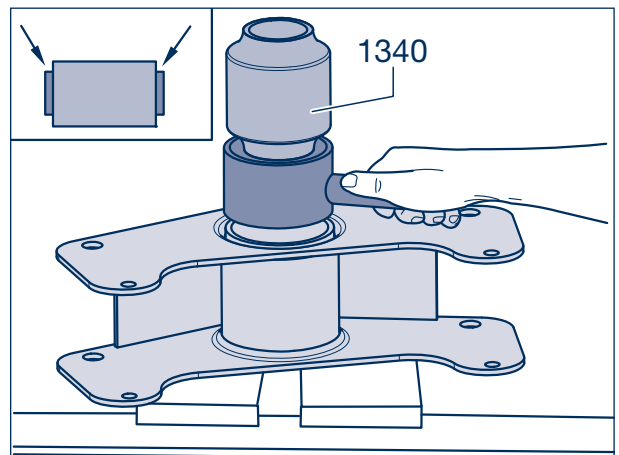

Picture 11

[12] For equalising beams with an offset A of 122 mm, press in a rubber-steel bush (1340) from each side until flush.

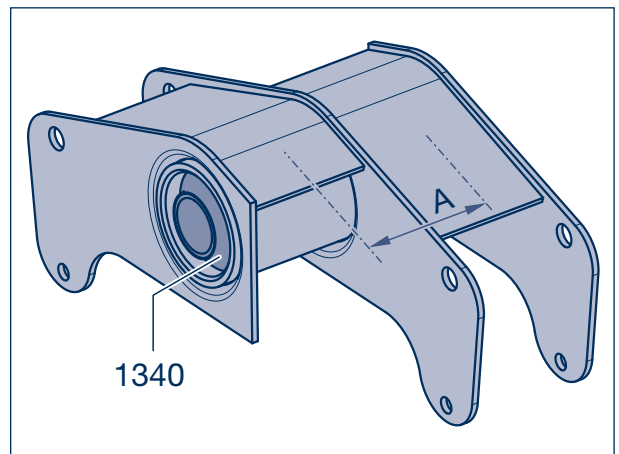

Picture 12

- [13] For equalising beams with an offset A of 160 mm, a spacer sleeve (1341) must be inserted between the rubber-steel bushes (1340).
- [14] Insert threaded bolt as guide into the bushes and press in bushes (1340).
- [15] To ensure that the bushes are flush, they must be pressed in a little further to compensate for relaxation.
When the bushes have been pressed into position, they have to be equally flush on both sides of the equalising beam.

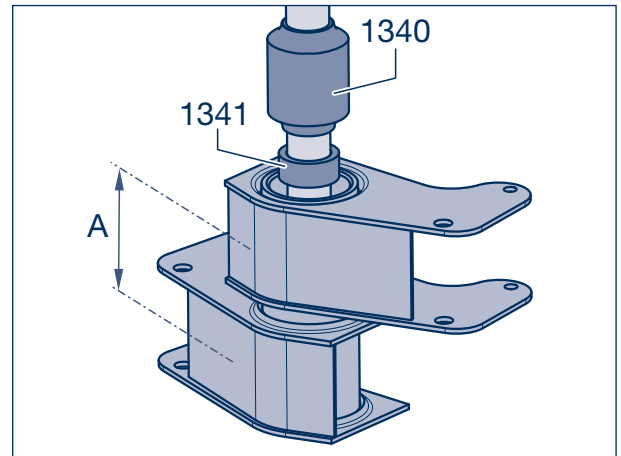

Picture 13

10.4 Install equaliser beam

Suspension versions VB...EC:

- [16] Check wear plates (1350) and wear discs (1352) for wear, replace if necessary and weld-tack again.
- [17] Insert equaliser beam (1320) into the hanger bracket.

☞ Continue with work step [18] on page 40.

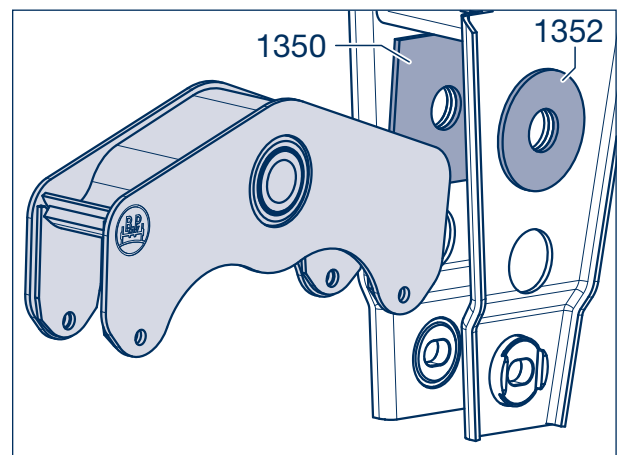

Picture 14

Suspension versions up to 07.2013 and VB...HD / HDE with loose wear rings

- [16] Check rings (1350) and weld-in bushes (1205) for wear and replace if necessary. Smear rings on both sides with grease and place on the equaliser beam.
- [17] Insert equaliser beam (1320) with rings into the hanger bracket.

☞ Continue with work step [18] on page 40.

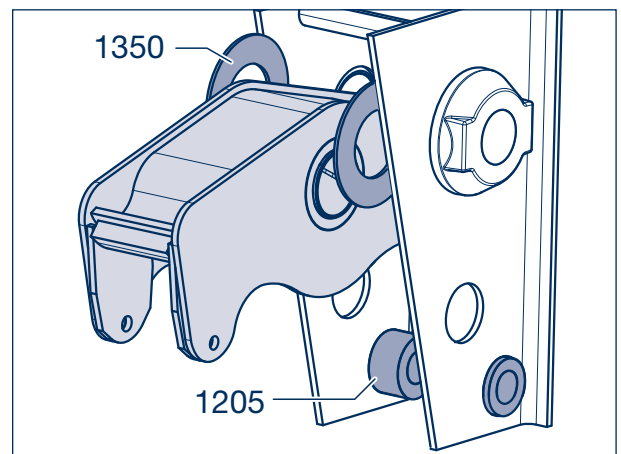

Picture 15

10 Removing and installing equalising beam

Suspension versions up to 07.2013 and VB...HD / HDE with welded wear plates

- [16] Check welded wear plates (1350) on the equalising beam and weld-in bushes (1205) in the hanger bracket for wear and replace if necessary. Grease wear plates.
- [17] Insert equalising beam (1320) into the hanger bracket.

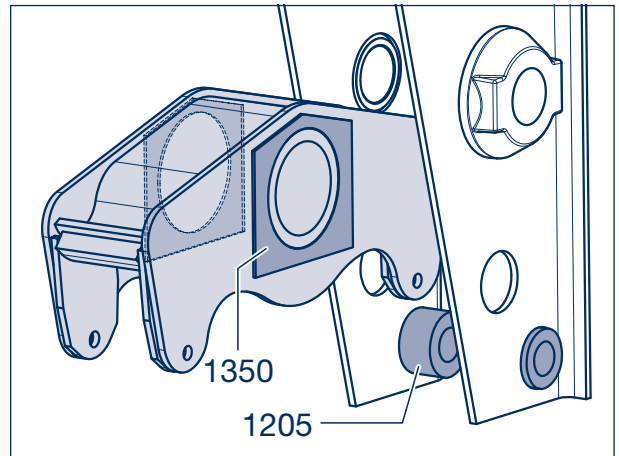

Picture 16

- [18] Grease thread bolt (1345) and insert from outside to inside into the bore hole support / equalising beam. The head of the threaded bolt must be inserted in the anti-rotation device (1370).

☞ See Chapter 10.4 on page 39 for installation of equalising beam.

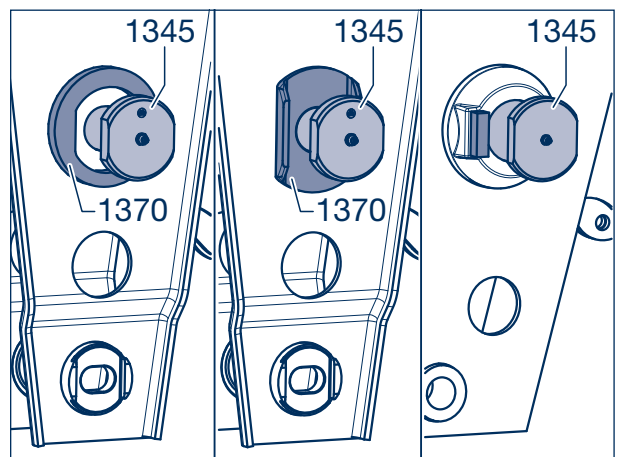

Picture 17

- [19] Smear the disc (1353) with grease and push onto the threaded bolt (1345).
- [20] Screw on new lock nut or castle nut (1360, SW 65) and tighten to the specified torque.

Tightening torques:

up to 12 t	(from 08/2013)
	M 42 x 3 M = 1300 Nm
up to 12 t	(up to 07/2013)
	M 42 x 3 M = 1100 Nm
from 13 t	M 42 x 3 M = 1700 Nm
serie HD / HDE	M 48 x 3 M = 1200 - 1300 Nm

- [21] If necessary, tighten castle nut up to the next locking option and secure with cotter pin (1361).

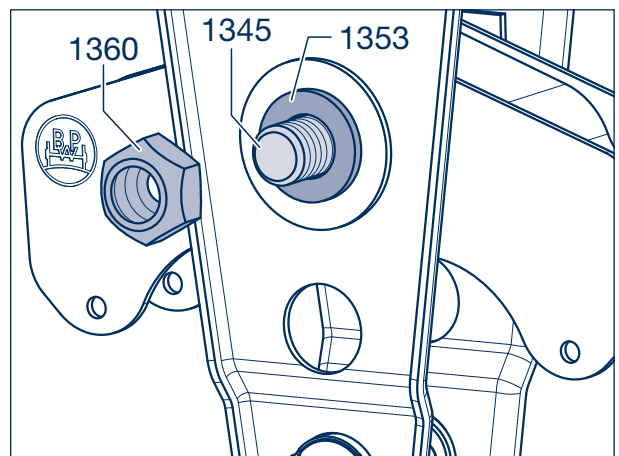

Picture 18

Version with bronze bushes

- [22] Screw grease nipple (1347) into the face of the thread bolt (1345) and lubricate with BPW special longlife grease ECO-Li^{Plus} until grease appears out of the bearing.

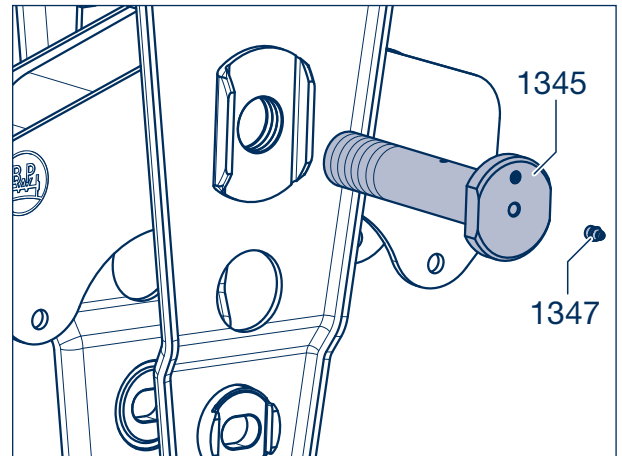

Picture 19

- [23] Insert axle with leaf spring into the equalising beam.



Repair guide!
In the case of a spring with an additional leaf the spring must be clamped together.

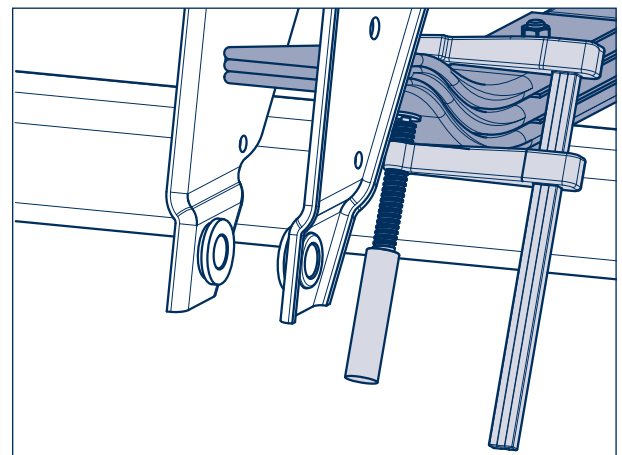

Picture 20

- [24] Insert the support (1230) into the equalising beam. Insert upper securing bolt (1240) and fit locking nut (1244, SW 30).

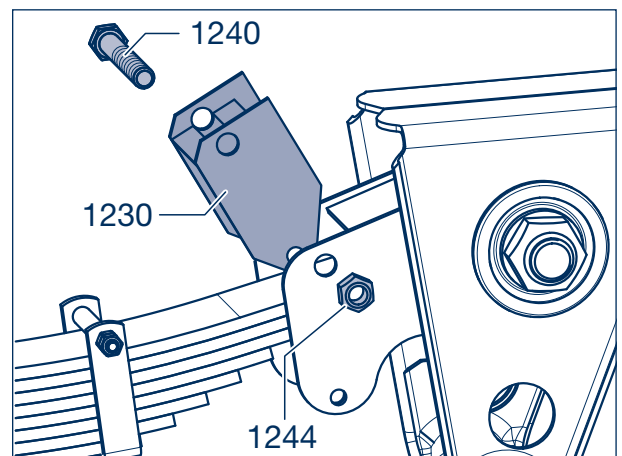

Picture 21

10 Removing and installing equalising beam

- [25] Check slider (1415) or rubber roller with tube (1245) for wear, exchange if necessary and insert into the equalising beam (grease nipple on slider must point to axle (arrow)).
- [26] Insert securing bolt (1235) and fit locking nut (1238, SW 22).
- [27] If removed, assemble plates (1232) and sliders (1230) (see picture 4 on page 36) on to the support and grease.

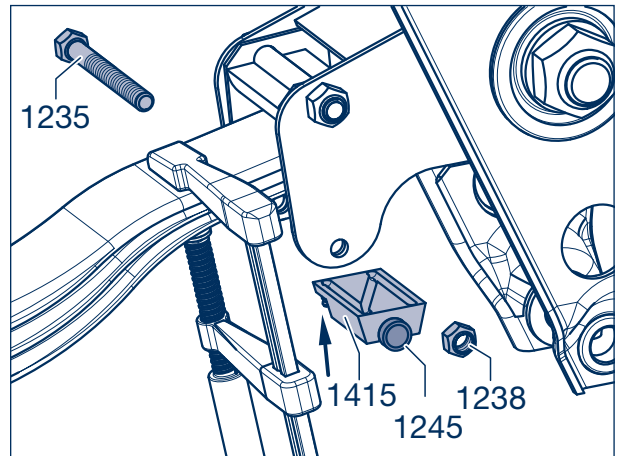

Picture 22

- In the case of welded support design, insert new support (spring slide, 1230). Insert lower securing bolt (1235) with tube (1245) and fit locking nut (1238, SW 22).
- Place weight on the leaf springs by lowering the vehicle.



Repair guide!

During welding work, protect the leaf springs, plastics and other sensitive components from weld spatter and heat.

Under no circumstances should the earth terminal be attached to the leaf spring or the hub.

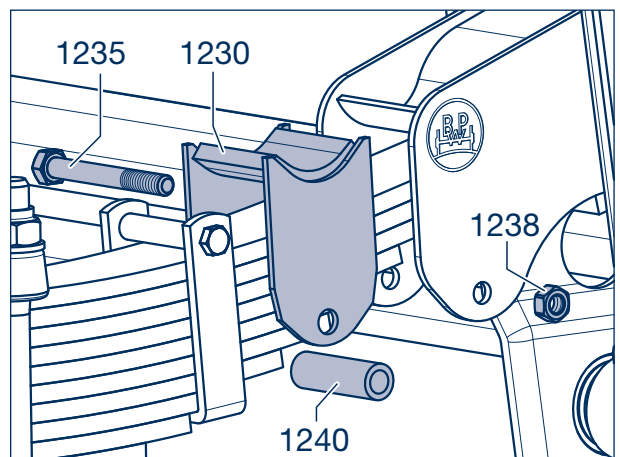

Picture 23

- [28] Fasten slider above with two short weld seams (1230/arrows), observing the correct position of the support.

Correct

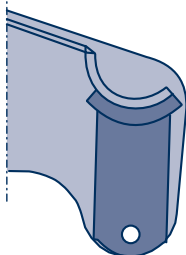

Wrong

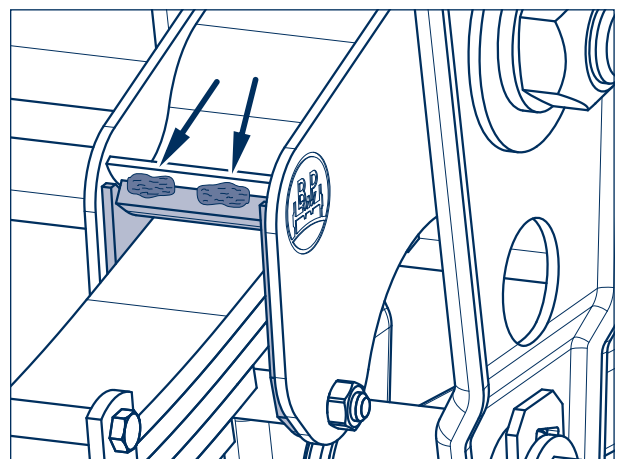
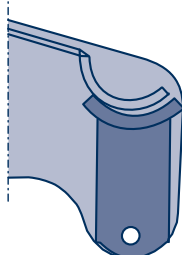

Picture 24

[29] Tighten locking nuts (1238, 1244) to the specified torque.

Tightening torques:

M 14 (SW 22)

M = 140 Nm

M 20 (SW 30)

M = 320 Nm

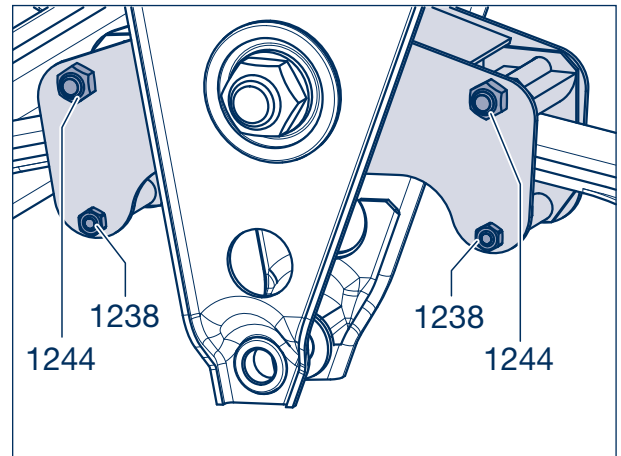

Picture 25

[30] Insert connecting rod (1100, 1105) into the hanger bracket.

[31] See page 28, from work step [37] for screw connection of the connecting rod.

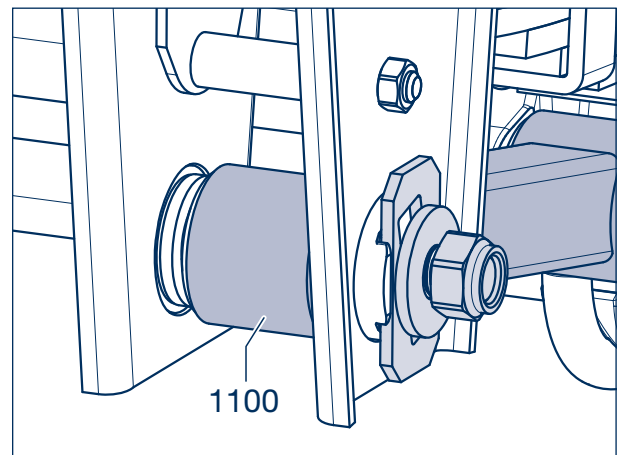

Picture 26

11 Axle alignment check



Note:
Begin the measurements on tandem-axle vehicles at the front axle and on tri-axle at the centre axle (reference axle).



Repair guide!
In the case of suspensions with a self-steered axle engage the steering lock. Zero position of the steering turntable is absolutely essential.



Note:
In suspensions with new hub caps (embossed ®, ECO or ECO Plus under the BPW logo) (Figure 1), as well as in ECO Plus 3, only the hub caps need to be unscrewed from the reference axis.

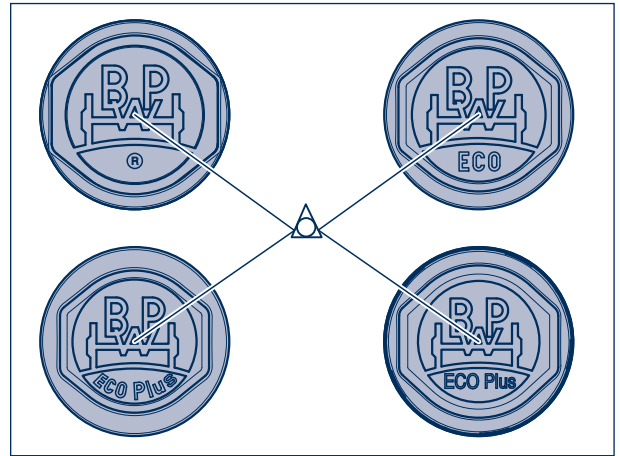

Picture 1

- [1] In the case of old hub caps as in picture 1, unscrew the hub caps and remove the grease from the wheel hubs.

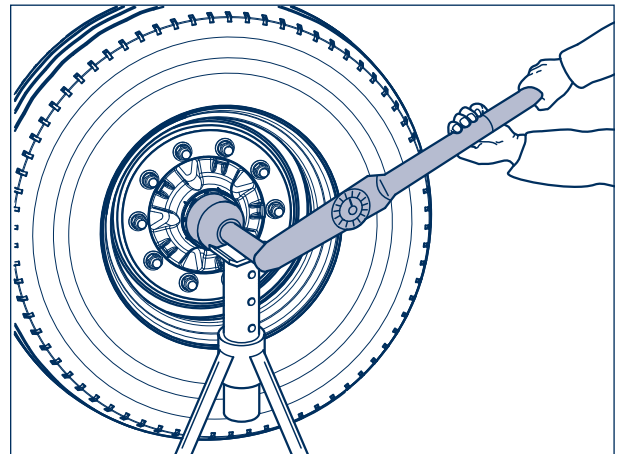

Picture 2

- [2] Fit threaded adapters (1) (BPW no. see chapter 2) onto the wheel hubs of the reference axle, screw in both aligning tubes (2) and raise the reference axle far enough until both wheels are clear of the ground.

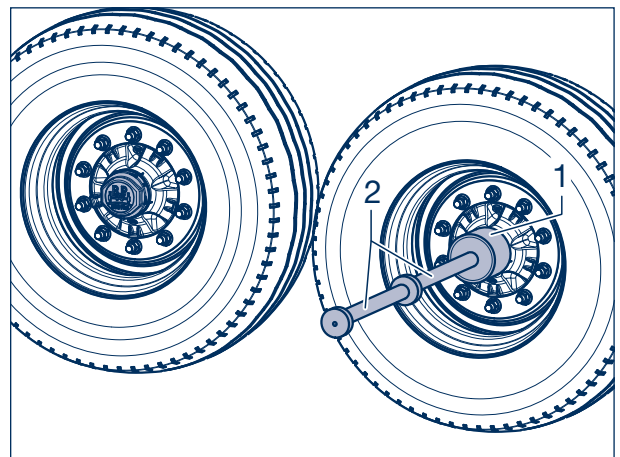

Picture 3

- [3] With the wheel rotating freely, determine the highest point of the run out at the alignment tubes (with parallel marking tool) and turn until it is at the top. Lower axle onto the ground.

**Note:**

If no parallel marking tool is available, the run out of the aligning tubes can also be marked with a piece of chalk; place a piece of wood or similar on the ground for this purpose. Turn wheel and then mark the highest point of the run out with chalk.

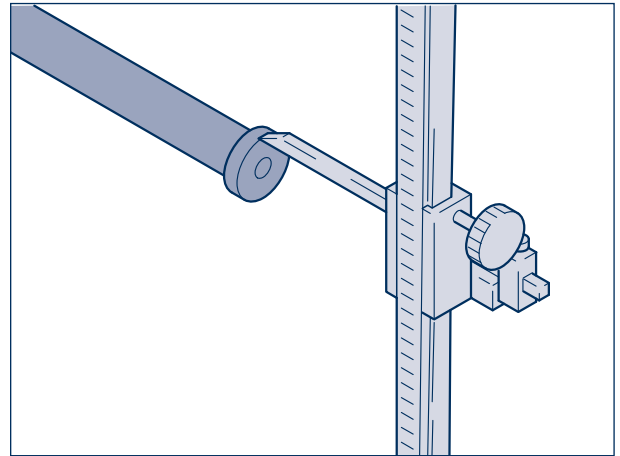

Picture 4

- [4] Determine the diagonal dimensions, A-B and A-C for the reference axle by taking comparison measurements (tolerance ± 2 mm).

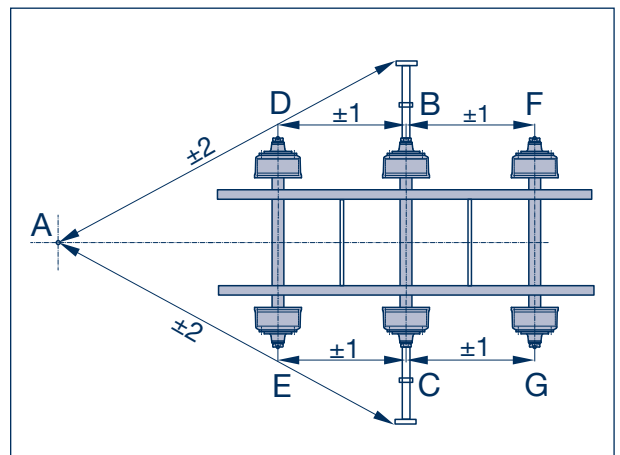

Picture 5

Suspension versions up to 07.2013 and VB...HD / HDE

- [5] To adjust to correct alignment, unscrew the bolts (1123, SW 19 / SW 22) on the connecting rod (1105).

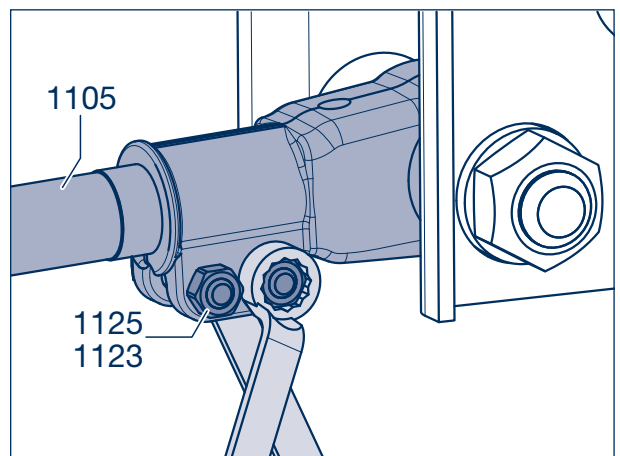

Picture 6

11 Axle alignment check

- [6] Turn the adjustable connecting rod (SW 36) with left- and right-hand thread in the appropriate direction.
- [7] Repeat measurements until the diagonal dimensions A-B and A-C are of equal size (picture 5).
- [8] After the measurement has been completed, tighten the securing nuts (1125) of the bolts (1123) to the specified torque.

Tightening torques:

M 12 (SW 19)	M = 66 Nm
M 14 (SW 22)	M = 140 Nm

 Continue with work step [9] on page 47.

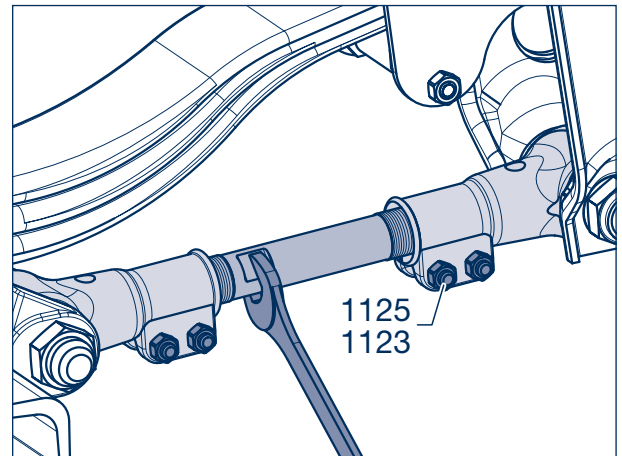

Picture 7

Suspension versions VB...EC:

- [5] Loosen the lock nuts (1168 SW 36) on the tie rods (1100) slightly and evenly shift the link disk (1161) on both sides, depending on the tracking direction, upwards or downwards with light hammer blows (Figure 9) for adjustment.

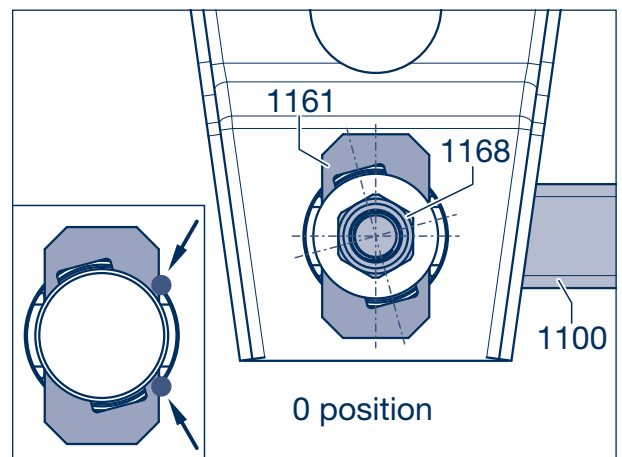

Picture 8

- [6] Tighten the locknut to the specified torque after adjustment.

Tightening torque with a torque wrench:
M 24 (SW 36) M = 650 Nm



Repair guide!
For difficult road conditions the link discs (1161) can be tack-welded after track adjustment (Figure 8, arrows).

 Continue with work step [9] on page 47.

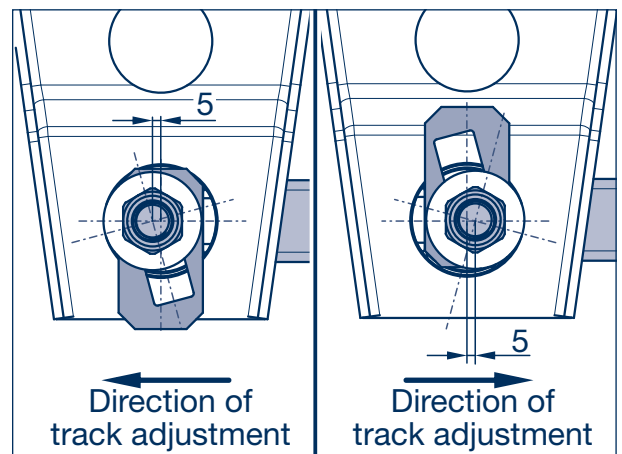

Picture 9

- [9] If necessary, refill hub caps with a little special BPW longlife grease ECO-Li^{Plus} (not necessary in ECO and ECO Plus Unit) and install to the specified torque, see embossing on cap.

- The triangle (Δ) in the BPW sign is centred, when an $\text{\textcircled{R}}$, ECO or ECO^{Plus} is embossed under the BPW sign or an ECO Plus 3 cap has been used.

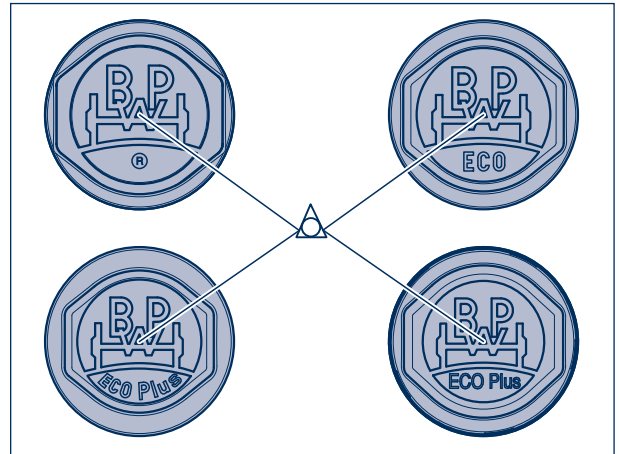

Picture 10

- [10] Measure distance from the reference axle to the nearest axles with lathe centers in the triangle of the hub caps (picture 10) or, in the case of old hub caps, in the recesses of the axle stub; permissible tolerance ± 1 mm (picture 5).

- [11] If measurements deviate, perform setting steps as described from work steps [5].

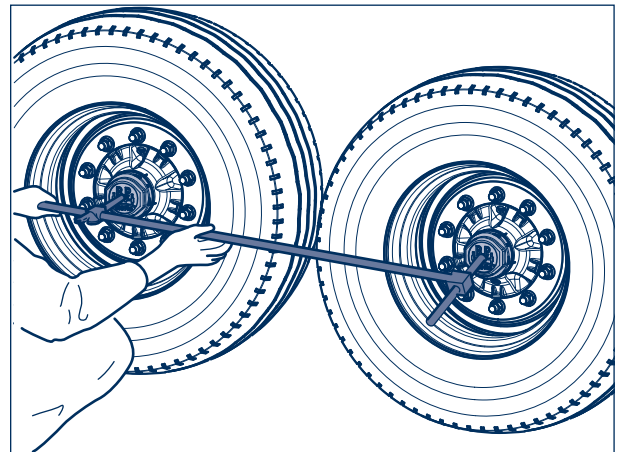

Picture 11

- [12] If old hub caps are disassembled, refill with some BPW special long durability grease ECO-Li^{Plus}, if needed, and refit in with the specified torque.

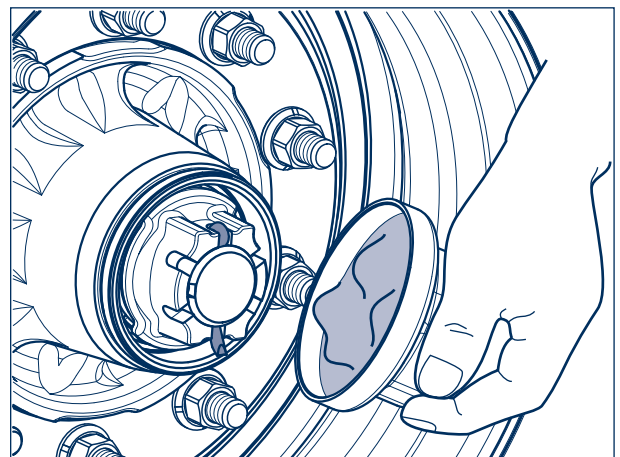

Picture 12

12 Axle alignment check with laser measuring devices

- [1] Set up the laser in accordance with the manufacturer's instructions. Make sure the axle is positioned horizontally to avoid camber values corrupting the measuring results.

Calculating the toe values:

$$\text{Toe} = \frac{A1 - B1 \text{ (mm)}}{A \text{ (m)}} \quad \begin{array}{l} \text{Positive value} = \text{Toe-in} \\ \text{Negative value} = \text{Toe-out} \end{array}$$

- [2] Perform the measurement on both sides and add together the measurement value. The total of the values is the toe-in/toe-out value of the axle and must be within the permitted tolerance range.

Permitted toe tolerance range per axle:

for rigid axles: -1 to +5 mm/m

for LL axles

unladen: -2 to +2 mm/m

laden: 0 to +6 mm/m

- [3] Correct alignment in case of impermissible tolerance values (see chapter 11, from working step [5]).

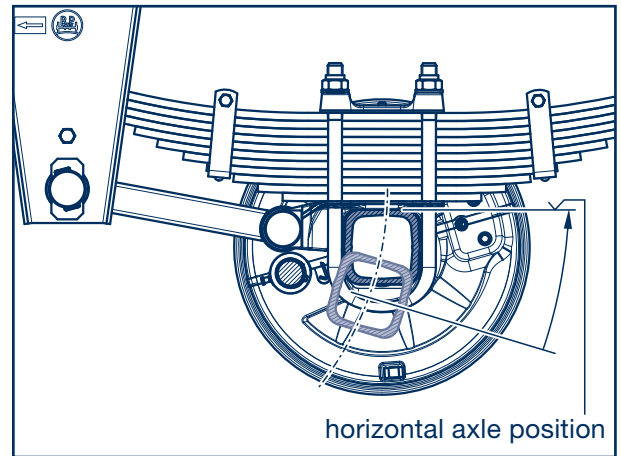

Picture 1

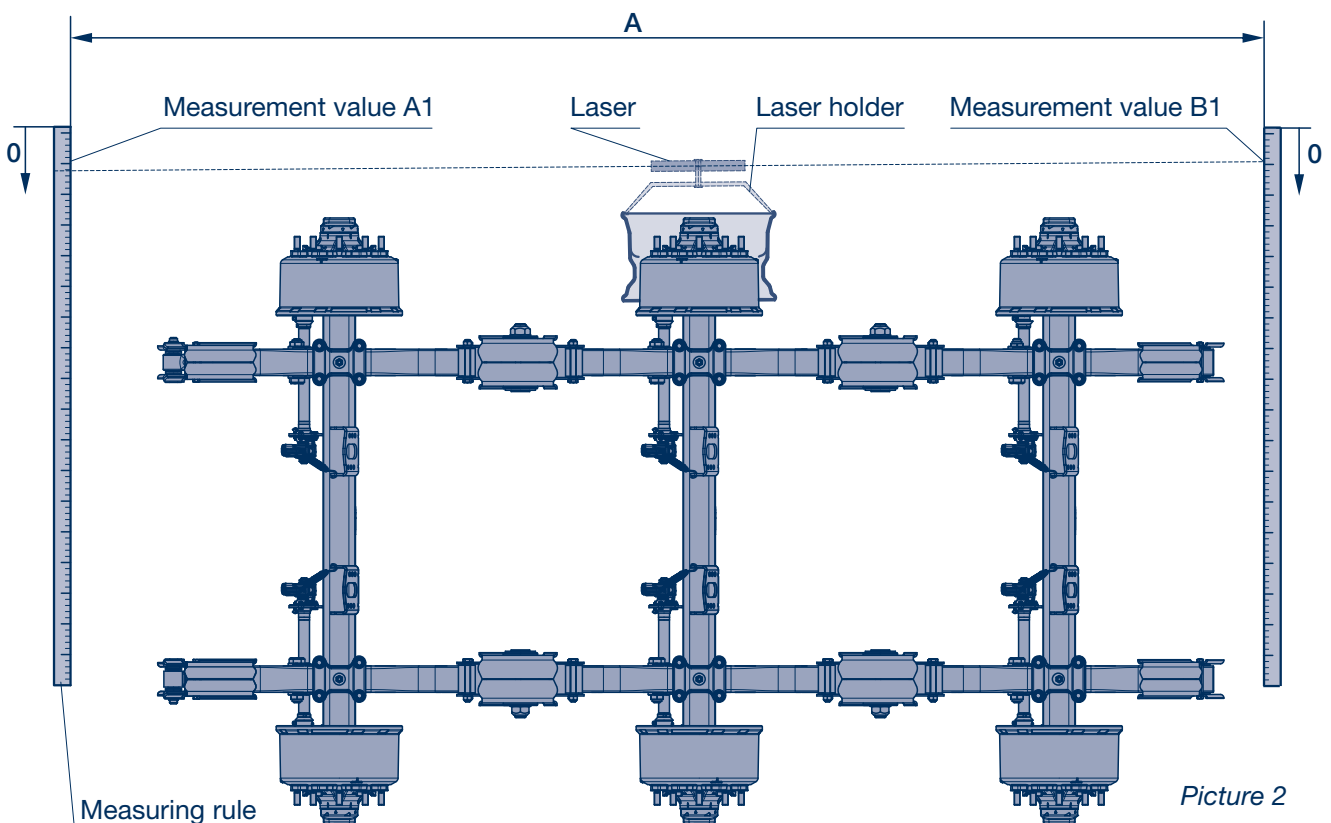

Picture 2

Notes



BPW-WH-VB 35431501e

BPW is a globally leading manufacturer of intelligent running gear systems for trailers and semi-trailers. As an international mobility and system partner, we offer a wide range of solutions for the transport industry from a single source, from axle to suspension and brake to user-friendly telematics applications.

We thereby ensure outstanding transparency in loading and transport processes and facilitate efficient fleet management. Today, the well-established brand represents an international corporation with a wide product and service portfolio for the commercial vehicle industry. Offering running gear systems, telematics, lighting systems, composite solutions and trailer superstructures, BPW is the right system partner for automotive manufacturers.

BPW, the owner-operated company, consistently pursues one target: To always give you exactly the solution which will pay off. To this end, we focus our attention on uncompromising quality for high reliability and service life, weight and time-saving concepts for low operating and maintenance costs as well as personal customer service and a close-knit service network for quick and direct support. You can be sure that with your international mobility partner BPW, you always use the most efficient method.

Your partner on the path to economic viability



BPW Bergische Achsen Kommanditgesellschaft

Postbox 12 80 · 51656 Wiehl, Germany · Phone +49 (0) 2262 78-0
info@bpw.de · www.bpw.de